



Bruxelles, le 21 janvier 2022
(OR. fr, en)

5456/22

LIMITE

**MI 50
ECO 5
ENT 7
IND 17
TELECOM 17**

NOTE

Origine:	Présidence / Secrétariat Général du Conseil
Destinataire:	Comité des représentants permanents
Objet:	Directive modifiant la directive 2014/53/UE concernant la mise à disposition sur le marché d'équipements radioélectriques (Chargeur universel) Mandat de négociation avec le Parlement européen

I. INTRODUCTION

1. Le 23 septembre 2021, la Commission a transmis la proposition de directive du Parlement européen et du Conseil visée en objet modifiant la directive 2014/53/UE relative à l'harmonisation des législations des États membres concernant la mise à disposition sur le marché d'équipements radioélectriques.
2. En rendant obligatoire, pour une grande variété d'appareils électroniques (téléphones mobiles, appareils photographiques numériques, consoles de jeu, haut-parleurs et casques d'écoute) la présence d'un port USB de type C, la proposition vise à réduire les coûts et les déchets électroniques, l'harmonisation et l'interopérabilité entre les appareils électroniques et les chargeurs. Par ailleurs, la proposition vise également à donner aux consommateurs le choix d'acheter ou non un chargeur avec un nouvel appareil (découplage).
3. Le Comité Économique et Social Européen a rendu son avis le 29 octobre 2021.

4. La commission compétente au sein du Parlement européen est la commission du marché intérieur et de la protection des consommateurs (IMCO) et M. Alex AGIUS SALIBA (S&D MT) est le rapporteur. Le Parlement n'est pas encore parvenu à un texte de compromis.

II. TRAVAUX CONDUITS AU SEIN DU CONSEIL ET PRINCIPAUX CHANGEMENTS APPORTÉS AU TEXTE

5. La première réunion du groupe «Harmonisation technique» (Équipements radioélectriques) s'est tenue le 5 octobre 2021 sous la Présidence slovène. Au cours de la réunion, la Commission a présenté la proposition.
6. Huit réunions du groupe ont été menées depuis le début de l'examen de la proposition au Conseil. Un premier texte de compromis a été envoyé aux délégations le 11 novembre 2021. Le groupe «Harmonisation technique» s'est réuni une dernière fois le 14 janvier 2022 où les États membres ont été invités à s'exprimer sur l'encadrement de la délégation de pouvoir et à faire part de leurs remarques concernant le texte de compromis en date du 13 décembre 2021.
7. Parmi les principaux changements par rapport à la proposition de la Commission, les États membres ont souhaité renforcer l'information fournie aux consommateurs (par l'ajout d'éléments visuels) et mieux encadrer la délégation de pouvoir pour l'adaptation des spécifications techniques.
8. Concernant les éléments visuels, les délégations ont insisté sur l'importance de leur neutralité linguistique. Par ailleurs, certains États membres ont également émis des doutes quant au visuel représentant un dispositif de charge qui semblerait moins approprié dans leur contexte national.
9. Une attention particulière a été accordée au considérant 9 de la proposition et à l'article 1 (1) de la proposition. En effet, plusieurs États membres ont souhaité clarifier les critères de déclenchement et l'encadrement de la délégation de pouvoir à la Commission: leur demande était de préciser la démarche de la Commission pour l'adaptation des spécifications techniques, notamment dans l'hypothèse d'une absence de norme européenne ou internationale permettant l'atteinte des objectifs de la directive.

10. En tenant compte de ces observations et de ces retours d'information, la Présidence a élaboré la proposition de compromis figurant en annexe. En particulier, la Présidence s'est attachée à mieux préciser l'encadrement de la délégation de pouvoir au considérant 9 et à refléter ces éléments dans la partie opérative de la proposition à l'article 1 (1). Elle a également modifié les éléments visuels (Parties III et IV de l'Annexe) afin d'assurer leur neutralité linguistique. Enfin, les derniers commentaires techniques formulés par écrit par certains États membres ont conduit à la modification du considérant 16a, afin de clarifier les obligations induites par le découplage pour les différents acteurs économiques, vis-à-vis de l'usage du pictogramme.

CONCLUSION

11. Le texte de compromis de la Présidence figurant en annexe reflète les efforts constants déployés par la Présidence pour trouver un juste équilibre entre les différents intérêts sur les principales questions susmentionnées dans le but d'obtenir un mandat du Comité des représentants permanents pour entamer les négociations avec le Parlement dès que possible.
12. Dès lors, le Comité des représentants permanents est invité à approuver le compromis en annexe et à charger la Présidence d'entamer des négociations avec le Parlement européen dès que possible afin de parvenir à un accord en première lecture sur cette base.

Comme indiqué dans la note de la Présidence du 6 septembre 2019 sur l'ouverture et la transparence, la Présidence suggère que, si aucune objection n'est soulevée, le mandat approuvé par le Comité soit rendu public, conformément au règlement intérieur du Conseil.

Proposal for a

DIRECTIVE OF THE EUROPEAN PARLIAMENT AND OF THE COUNCIL

amending Directive 2014/53/EU on the harmonisation of the laws of the Member States relating to the making available on the market of radio equipment

(Text with EEA relevance)

THE EUROPEAN PARLIAMENT AND THE COUNCIL OF THE EUROPEAN UNION,

Having regard to the Treaty on the Functioning of the European Union, and in particular Article 114 thereof,

Having regard to the proposal from the European Commission,

After transmission of the draft legislative act to the national parliaments,

Having regard to the opinion of the European Economic and Social Committee¹,

Having regard to the opinion of the Committee of the Regions²,

Acting in accordance with the ordinary legislative procedure,

¹ OJ C , , p. .

² OJ C , , p. .

Whereas:

- (1) One of the objectives of Directive 2014/53/EU of the European Parliament and of the Council³ is to guarantee the proper functioning of the internal market. Pursuant to Article 3(3), point (a), of that Directive, one of the essential requirements that radio equipment must fulfil is that it interoperates with accessories, in particular with common chargers. In that respect, recital (12) of Directive 2014/53/EU indicates that the interoperability between radio equipment and accessories such as chargers simplifies the use of radio equipment and reduces unnecessary waste and costs.
- (2) Since 2009, efforts have been deployed at Union level to limit the fragmentation of the charging interfaces for mobile phones and similar items of radio equipment. Recent voluntary initiatives do not fully meet Union policy objectives to reduce electronic waste (e-waste), ensure consumer convenience and avoid fragmentation of the market for charging devices.
- (3) The Union is committed to boosting the efficient use of resources by moving to a clean, circular economy through the introduction of initiatives such as Directive 2012/19/EU of the European Parliament and of the Council⁴ and more recently through the introduction of the European Green Deal. This Directive aims to reduce the e-waste generated by the sale of radio equipment and to reduce the extraction of raw materials and the CO₂ emissions generated by the production, transportation and disposal of chargers, thereby promoting a circular economy.
- (4) The Commission's Circular Economy Action Plan provided for initiatives along the entire life cycle of products, targeting their design, promoting circular economy processes, fostering sustainable consumption, and aiming to ensure that the resources used are kept in the Union economy for as long as possible.

³ Directive 2014/53/EU of the European Parliament and of the Council of 16 April 2014 on the harmonisation of the laws of the Member States relating to the making available on the market of radio equipment and repealing Directive 1999/5/EC (OJ L 153, 22.5.2014, p. 62).

⁴ Directive 2012/19/EU of the European Parliament and of the Council of 4 July 2012 on waste electrical and electronic equipment (WEEE) (OJ L 197, 24.7.2012, p. 38).

- (5) The Commission completed an impact assessment study, which has shown that the internal market is not exploiting its full potential as continuing fragmentation of the market for charging interfaces and charging communication protocols for mobile phones and other similar radio equipment results in a lack of consumer convenience and an increase in e-waste.
- (6) The interoperability between radio equipment and accessories such as chargers is hampered as there are different charging interfaces for certain categories or classes of radio equipment that use wired charging such as handheld mobile phones, tablets, digital **photo/video** cameras **not intended for professional private use**, headphones or headsets, handheld videogame consoles and portable speakers. In addition, there are several types of fast charging communication protocols for which a minimum level of performance is not always guaranteed. As a result, Union action is required to promote a common degree of interoperability and the provision of information relating to the charging characteristics of radio equipment to **consumers and other** end-users. It is therefore necessary to introduce suitable requirements in Directive 2014/53/EU regarding the charging communication protocols, the charging interface (i.e. charging receptacle) of certain categories or classes of radio equipment, as well as the information to be provided to **consumers and other** end-users regarding the charging characteristics of those categories or classes of radio equipment.
- (7) The absence of harmonisation in this area may lead to substantial differences between the Member States' laws, regulations, administrative provisions or practices on the interoperability of mobile phones and similar categories or classes of radio equipment with their charging devices, and on the supply of radio equipment without charging devices.
- (8) The size of the internal market in rechargeable mobile phones and similar categories or classes of radio equipment, the proliferation of different types of charging devices for such radio equipment and the significant cross-border trade of those products calls for stronger legislative action at Union level rather than either national level or voluntary measures, so as to achieve the smooth functioning of the internal market.

- (9) It is therefore necessary to harmonise the charging interface and charging communication protocols for specific categories or classes of radio equipment that are recharged via wired charging. It is also necessary to provide the basis for ~~adaptation~~^{adaption} to any future technological progress **or market developments, which will be continuously monitored by the Commission. In particular, by the introduction of** a harmonisation of the charging interfaces and the charging communication protocols **should in the future also be considered** with respect to radio equipment that may be charged via any means other than wired charging including charging via radio waves (wireless charging). Such harmonisation should reduce environmental waste, ensure consumer convenience and avoid fragmentation of the market among different charging interfaces and charging communication protocols as well as among any initiatives at national level, which might cause barriers to trade in the internal market. **The future adaptation of the harmonisation should continue to pursue these objectives by ensuring that it incorporates the most appropriate technical solutions for the wired and wireless charging interfaces and charging communication protocols. Relevant technical standards fulfilling the objectives of this Directive and having been developed at European or international level should represent the guiding principle for the selection of such technical solutions.**
- The harmonised technical solutions should reflect the most appropriate combination between the market alignment acceptance as well as the objectives of reduction of environmental waste, consumer convenience and avoidance of market fragmentation. Relevant technical standards fulfilling the objectives above of this Directive and having been developed at European or international level should primarily be used for the selection of such technical solutions. In exceptional cases where there is a need to introduce, add or modify an existing technical specification in the absence of publicly available European or international standards that fulfill the objectives mentioned above, the Commission should be able to reference other technical specifications, provided that these have been developed in line with the criteria of openness, consensus and transparency, and that they meet the requirements of neutrality and stability, as referred to in Annex II of Regulation (EU) No 1025/2012 on European Standardisation. All the relevant sectoral stakeholders represented in the Commission Expert Group on Radio Equipment should be involved in the process throughout the adaptation of the harmonisation.**

- (10) Such harmonisation would be however incomplete, if it is not combined with requirements regarding the combined sale of radio equipment and their chargers and information to be provided to **consumers and other** end-users. A fragmentation of approaches among the Member States with respect to the marketing of the categories or classes of radio equipment concerned and their charging devices would hamper the cross-border trade in those products, for example by obliging economic operators to repackage their products depending on the Member State, in which the products are to be supplied. This would in turn result in increased inconvenience for consumers and would generate unnecessary e-waste thus offsetting the benefits derived from the harmonisation of the charging interface and charging communication protocol. It is therefore necessary to impose requirements to ensure that **consumers and other** end-users are not obliged to purchase a new charging device with each purchase of a new mobile phone or similar item of radio equipment. To ensure the effectiveness of such requirements, **consumers and other** end-users should receive the necessary information regarding the charging characteristics when purchasing a mobile phone or similar item of radio equipment. **A dedicated pictogram should enable consumers and other end-users to determine whether or not a charging device is included with the radio equipment before the purchase. The pictogram should be displayed in the case of all forms of supply, including distance selling.**
- (11) It is technically feasible to define USB Type-C as the common charging receptacle for the relevant categories or classes of radio equipment. The USB Type-C technology, which is being used globally has been adopted at international standardisation level and has been transposed into the European system by the European Committee for Electrotechnical Standardization (CENELEC) under the European Standard EN IEC 62680-1-**3:2021** **Universal serial bus interfaces for data and power - Part 1-3: Common components - USB Type-CTM Cable and Connector Specification** series⁵.

⁵ ~~Universal serial bus interfaces for data and power – Part 1-3: Common components – USB Type-CTM Cable and Connector Specification~~

- (12) USB Type-C is a technology that is already common to many categories or classes of radio equipment as it provides high-quality charging and data transfer. The USB Type-C charging receptacle, when combined with the USB Power Delivery charging communication protocol, is capable of providing up to 100W of power and therefore leaves ample room for further development of fast charging solutions, while allowing the market to cater for low-end phones that do not need fast charging. Mobile phones and similar radio equipment that support fast charging can incorporate the USB Power Delivery features as described in standard EN IEC 62680-1-2:~~2021~~ 2020 ‘Universal serial bus interfaces for data and power - Part 1-2: Common components - USB Power Delivery specification’.
- (13) With respect to charging by means other than wired charging, divergent solutions may be developed in the future, which may have negative impacts on interoperability, consumer convenience and the environment. Whilst it is premature to impose specific requirements on such solutions at this stage, the Commission should be able to take action towards harmonising them in the future, if fragmentation on the internal market is observed.
- (14) Article 3 of Directive 2014/53/EU should be amended in order to cover charging interfaces and charging communication protocols. The categories or classes of radio equipment specifically covered by this new provision should be further detailed in a new annex to Directive 2014/53/EU.
- (15) Directive 2014/53/EU should also be amended in order to insert a new Article which will relate to the requirements on the supply of certain categories or classes of radio equipment without charging devices. ~~**A dedicated pictogram should enable consumers and other end-users to determine whether or not a charging device is included with the radio equipment before the purchase.**~~ The categories or classes of radio equipment concerned as well as the specifications in relation to charging solutions should be specified in a new annex to Directive 2014/53/EU.

(16) Article 10(8) of Directive 2014/53/EU provides for information to be included in the instructions for use and so additional information requirements should be inserted in that Article. The details **content** of the new requirements should be specified in the new annex to Directive 2014/53/EU. ~~In view of providing consumers and other end-users with timely and exhaustive information,~~ **Certain elements of information should also be provided by means of visual elements for all forms of supply, including distance selling. A dedicated pictogram will** Those information requirements would enable consumers ~~and other end-users~~ to determine ~~whether the radio equipment is supplied with or without a charging device before the purchase.~~ **A dedicated label indicating the specifications relating to charging capabilities and compatible chargers will enable the consumers and other end-users to determine** the most appropriate external power supply (EPS) needed to charge their radio equipment. **In order to provide a source of useful reference throughout the life cycle of the radio equipment, the information on the charging capabilities and compatible chargers should also be included in the instructions and safety information accompanying the radio equipment.** It should be possible to adapt those requirements in the future in order to reflect any changes to the labelling requirements for EPS, which may be introduced under Directive 2009/125/EC of the European Parliament and of the Council⁶.

(16a) Considering that importers and distributors may also supply radio equipment directly to consumers and other end-users, identical obligations to the ones applicable to manufacturers in relation to the information to be supplied or displayed should be introduced. In relation to the pictogram indicating whether or not a charging device is included with the radio equipment, all economic operators should fulfil this obligation when making radio equipment available to consumers and other end-users. Therefore, importers and distributors may offer bundles, which include the radio equipment its charging device even when such radio equipment is supplied without a charging device by the manufacturer, provided that they also offer to consumers and other end-users the possibility to acquire the radio equipment without any charging device.

⁶ Directive 2009/125/EC of the European Parliament and of the Council of 21 October 2009 establishing a framework for the setting of ecodesign requirements for energy-related products (OJ L 285, 31.10.2009, p. 10).

- (17) Article 17 of Directive 2014/53/EU, which sets out the conformity assessment procedures, should be amended in order to add references to the new essential requirements to be inserted in Article 3 of that Directive. The manufacturer should thus have the choice of following the internal control procedure in order to demonstrate compliance with those new essential requirements.
- (17a) **In order to ensure that national market surveillance authorities would have the procedural means to enforce the new requirements regarding the harmonised charging interface and charging communication protocol and regarding the requirements concerning the supply of radio equipment subject to such harmonisation, Articles 40 and 43 of Directive 2014/53/EU should be adapted accordingly. In particular, an explicit reference to the lack of compliance with the essential requirements, which also include the newly introduced provisions on specifications on charging, should be included in Article 40. Considering that these newly introduced provisions are focusing on interoperability aspects, the objective of this explicit reference is to avoid divergent interpretations as to whether the procedure laid down in Article 40 of Directive 2014/53/EU may be triggered also in respect of radio equipment, which does not present an immediate risk to the health and safety of persons or to other aspects of public interest protection covered by Directive 2014/53/EU.**
- (18) Articles 40, 43 and 44 of Directive 2014/53/EU should be amended in order to adapt the references that they contain to the new provisions that are introduced by this Directive.
- Article 43 of Directive 2014/53/EU enumerates the instances of formal non-compliance. Considering that ~~Article 3(4), Article 3a and Article 10(8)~~ this Directive introduces new requirements applicable to certain categories or classes of radio equipment, Article 43 of Directive 2014/53/EU should be adjusted in order to allow the effective enforcement of these requirements by the national market surveillance authorities.**
- (18a) **Article 44 of Directive 2014/53/EU should be amended in order to adjust the references contained therein to the new requirements introduced by this Directive. ~~the new Article 3(4) and the amended Article 10(8) of Directive 2014/53/EU.~~**

- (19) In order to address any future developments in charging technology and to ensure the minimum common interoperability between radio equipment and the charging devices for such radio equipment, the power to adopt acts in accordance with Article 290 of the Treaty on the Functioning of the European Union should be delegated to the Commission to amend the categories or classes of radio equipment and the specifications regarding the charging interfaces and charging communication protocols, as well as the details on the information in relation to charging.

The power to adopt acts in accordance with Article 290 of the Treaty on the Functioning of the European Union should be delegated to the Commission in order to

~~amend the categories or classes of radio equipment and the specifications regarding the charging interfaces and charging communication protocols for each of them~~ **In order to ensure the minimum common interoperability between radio equipment and the charging devices for such radio equipment and to address any future market developments, such as the emergence of new categories or classes of radio equipment in relation to which a significant degree of fragmentation of the charging interfaces and charging communication protocols is observed, and any developments in charging technology, the power to adopt acts in accordance with Article 290 of the Treaty on the Functioning of the European Union should be delegated to the Commission in respect of amending categories or classes of radio equipment and the specifications regarding the charging interfaces and charging communication protocols for each of them.**

~~amend the information requirements regarding the charging interfaces and charging communication protocols~~ **In order to reflect, inter alia, future amendments to the labelling requirements for external power supplies the evolution of the EU framework regulating the ecodesign requirements for external power supplies or technical progress, the power to adopt acts in accordance with Article 290 of the Treaty on the Functioning of the European Union should be delegated to the Commission in respect of amending the information requirements regarding the charging interfaces and charging communication protocols.**

It is of particular importance that the Commission carry out appropriate consultations during its preparatory work, including at expert level, and that those consultations be conducted in accordance with the principles laid down in the Inter-institutional Agreement on Better Law-Making of 13 April 2016⁷. In particular, to ensure equal participation in the preparation of delegated acts, the European Parliament and the Council receive all documents at the same time as Member States' experts, and their experts systematically have access to meetings of Commission expert groups dealing with the preparation of delegated acts.

(19a) In order to ensure coherence between the provisions of this Directive and the provisions of Directive 2014/53/EU, where both the term ‘end-users’ and the term ‘consumers and other end-users’ are used in parallel, it is appropriate to clarify the notion of ‘consumers and other end-users’. It should be recalled that Directive 2014/53/EU applies to radio equipment, which is made available to all end-users, including consumers. In the same vein, this Directive also applies to all categories of end-users and consistently uses the term "consumers and other end-users". The definition of ‘end user’ laid down in Article 3(21) of Regulation (EU) 2019/1020 explicitly indicates that consumers are to be seen as a particular category of end-users, among others.

~~(19b) It is of particular importance that the Commission carry out appropriate consultations during its preparatory work, including at expert level, and that those consultations be conducted in accordance with the principles laid down in the Inter-institutional Agreement on Better Law-Making of 13 April 2016⁸. In particular, to ensure equal participation in the preparation of delegated acts, the European Parliament and the Council receive all documents at the same time as Member States' experts, and their experts systematically have access to meetings of Commission expert groups dealing with the preparation of delegated acts.~~

(20) Directive 2014/53/EU should therefore be amended accordingly.

⁷ OJ L 123, 12.5.2016, p. 1.

⁸ OJ L 123, 12.5.2016, p. 1.

- (21) Economic operators should be provided with sufficient time to proceed with the necessary adaptations to radio equipment falling within the scope of this Directive, which they intend to place on the Union market,

HAVE ADOPTED THIS DIRECTIVE:

Article 1

Directive 2014/53/EU is amended as follows:

(1) Article 3 is amended as follows:

(a) in paragraph 3, first subparagraph, point (a), the comma and the phrase ‘in particular with common chargers’ **are** ~~is~~ replaced by the phrase ‘other than the charging devices for the categories or classes of radio equipment, specified in Annex Ia, Part I, which are specifically referred to in paragraph 4 of this Article’ ;

(b) the following paragraph is added:

‘4. Radio equipment falling within the categories or classes specified in Annex Ia, Part I shall be so constructed that it complies with the specifications on charging **capabilities** set out in that Annex for the relevant category or class of radio equipment.

With respect to radio equipment capable of being recharged via wired charging, the Commission is empowered to adopt delegated acts in accordance with Article 44 to amend **Part I 1 of** Annex Ia in the light of technical progress **or market developments**, and to ensure the minimum common interoperability between radio equipment and their charging devices, by:

- (a) modifying, adding or removing categories or classes of radio equipment;
- (b) modifying, adding or removing technical specifications, including references and descriptions, in relation to the charging receptacle(s) and charging communication protocol(s), for each category or class of radio equipment concerned.²

With respect to radio equipment capable of being recharged via means other than wired charging, the Commission is empowered to adopt delegated acts in accordance with Article 44 in order to amend **Part I 1 of** Annex Ia in the light of technical progress **or market developments**, and to ensure the minimum common interoperability between radio equipment and their charging devices, by:

- (a) introducing, modifying, adding or removing categories or classes of radio equipment;
- (b) introducing, modifying, adding or removing technical specifications, including references and descriptions, in relation to charging interface(s) and charging communication protocol(s), for each category or class of radio equipment concerned.

When preparing the delegated acts referred to in this Article, the Commission shall take account of the degree of market acceptance of the technical specifications under consideration, the resulting consumer convenience and the extent of the reduction of environmental waste and market fragmentation that can be expected from such technical specifications. Technical specifications that are based on relevant available European or international standards shall be deemed to meet the objectives set out in the previous sentence. However, in cases where such European or international standards do not exist, or in cases where the Commission determines, based on a technical assessment, that they do not meet those objectives at the optimal manner, the Commission may reference other technical specifications which better meet those objectives.

(2) the following Article 3a is inserted:

Article 3a

Possibility for consumers and other end-users to acquire certain categories or classes of radio equipment without a charging device

- 1.** Where an economic operator offers to consumers and other end-users the possibility to acquire radio equipment referred to in ~~falling within the scope of Article 3(4) together with a charging device,~~ the consumers and other end-users shall also be offered the possibility to acquire the radio equipment without any charging device.?’;
- 2.** Economic operators shall, in accordance with their obligations stated in Chapter II of Directive 2014/53/EU, ensure that the information on whether or not a charging device is included with the radio equipment referred to in Article 3(4) shall be is displayed in a graphic form using a pictogram as set out in Annex Ia, Part III when such radio equipment is made available to consumers and other end-users. The pictogram shall be printed on the packaging or attached on the packaging as a sticker. Any visual advertisement organised by or on behalf of the manufacturer shall show the pictogram. If the visual advertisement indicates the price of that radio equipment, †The pictogram shall be displayed close to the price indication when the radio equipment is made available to consumers or other end-users. The Commission is empowered to adopt delegated acts in accordance with Article 44 in order to amend the Annex Ia, Part III, in relation to amendments of Parts I and II of that Annex, in relation to the future amendments to the labelling requirements for external power supplies evolution of the EU framework regulating the ecodesign requirements for external power supplies or in the light of technical progress, by introducing, modifying, adding or removing any graphic or textual elements.’;

(3) in Article 10(8), **is replaced by** the following subparagraph is added:

8. Manufacturers shall ensure that the radio equipment is accompanied by instructions and safety information. Instructions shall include the information required to use radio equipment in accordance with its intended use. Such information shall include, where applicable, a description of accessories and components, including software, which allow the radio equipment to operate as intended. Such instructions and safety information, as well as any labelling, shall be clear, understandable and intelligible.

The following information shall also be included in the instructions in the case of radio equipment intentionally emitting radio waves:

(a) frequency band(s) in which the radio equipment operates;

(b) maximum radio-frequency power transmitted in the frequency band(s) in which the radio equipment operates.

In the case of radio equipment referred to in Article 3(4) the instructions shall contain information on the specifications relating to the charging capabilities and the compatible charging devices, as described in Annex Ia, Part II. In addition to being included in the instructions accompanying the radio equipment, when the manufacturers make such radio equipment available to consumers and other end-users, the information shall be also displayed on a label, as set out in Part IV to Annex Ia. The label shall be printed on the packaging or attached on the packaging as a sticker. In the absence of a packaging, the sticker with the label shall be attached on the radio equipment. Where the size or nature of the radio equipment does not allow it, the label may be printed as a separate document accompanying the radio equipment. ~~Any visual advertisement organised by or on behalf of the manufacturers shall show the label. If the visual advertisement indicates the price of that radio equipment,~~ The label shall be displayed close to the price indication, when the radio equipment is made available to consumers or other end-users.

Instructions and safety information referred to in the first to third subparagraphs 1 to 3 shall be in a language which can be easily understood by consumers and other end-users, as determined by the Member State concerned, and shall be clear, understandable and intelligible. The Commission is empowered to adopt delegated acts in accordance with Article 44 in order to amend Annex Ia, Parts II and IV , to reflect amendments of Part I of that Annex, the future amendments to the labelling requirements the evolution of the EU framework regulating the ecodesign requirements for external power supplies or technical progress, by introducing, modifying, adding or removing any details in relation to the that information, graphic or textual elements, as set out in this Article.

In addition to being included in the instructions accompanying the radio equipment, the information referred to in subparagraph 3 shall be also displayed on a label, as set out in the Appendix to Annex Ia. The label shall be printed on the packaging or placed on the packaging as a sticker. In the absence of a packaging, the sticker with the label shall be placed on the radio equipment. Where the size or nature of radio equipment does not allow it, the label may be printed as a separate document accompanying the radio equipment. Any visual advertisement organised by or for the account of the manufacturers shall show the label. If the visual advertisement indicates the price of that radio equipment, the label shall be displayed close to the price indication. The Commission is empowered to adopt delegated acts in accordance with Article 44 in order to amend the Appendix to Annex Ia, in relation to amendments of Parts I and II of that Annex, to reflect the evolution of the EU framework regulating the ecodesign requirements for extenal power supplies or technical progress, by introducing, modifying, adding or removing any graphic or textual elements.

~~In the case of radio equipment referred to in Article 3(4), information on whether the radio equipment includes a charging device or not, shall be provided in such a way that it is visible when the radio equipment referred to in Article 3(4) is offered to consumers and other end-users. This information shall also be displayed in a graphic form using a pictogram as set out in Annex Ia, Part III. The pictogram shall be printed on the packaging or placed on the packaging as a sticker. In the absence of a packaging, the sticker shall be placed on the radio equipment. Any visual advertisement organised by or for the account of the manufacturers shall show the pictogram. If the visual advertisement indicates the price of that radio equipment, the pictogram shall be displayed close to the price indication. The Commission is empowered to adopt delegated acts in accordance with Article 44 in order to amend the Annex Ia, Part III, in relation to amendments of Parts I and II of that Annex, to reflect the evolution of the EU framework regulating the ecodesign requirements for external power supplies or technical progress, by introducing, modifying, adding or removing any graphic or textual elements.~~

~~Radio equipment falling within the scope of referred to in Article 3(4) first subparagraph shall be accompanied by information on specifications relating to charging capabilities and to its charging device, as described in Annex Ia, Part II. as well as information on whether the equipment includes a charging device or not. Both pieces of information should be indicated on the packaging or, in the absence of packaging, on a label attached to or, where this is not possible, accompanying the radio equipment.~~

~~Such information shall be in a language which can be easily understood by consumers and other end-users, as determined by the Member State concerned, and shall be clear, understandable and intelligible.~~

~~Also information on specifications relating to charging capabilities and to its charging device, as described in Annex Ia, Part II, should be included in the instructions of the radio equipment.~~

~~The Commission is empowered to adopt delegated acts in accordance with Article 44 in order to amend Annex Ia, Part II, by introducing, modifying, adding or removing any details in relation to that information or the way that such information shall be indicated.;~~

(3a) in Article 12(4) (2), the following subparagraph is added after the first subparagraph:

‘Importers shall ensure that radio equipment referred to in Article 3(4) displays and/or is supplied with the label and pictogram and label in accordance with respectively Article 3a(2) and Article 10(8), third subparagraph 5 and 6 when they make such radio equipment available to consumers and other end-users. Any visual advertisement organised by or on behalf of for the account of the Importers shall ensure that show the label and the pictogram are displayed close to the price indication when the radio equipment is made available to consumers or other end-users.. If the visual advertisement indicates the price of that radio equipment, the label and the pictogram shall be displayed close to the price indication.’;

(3b) In Article 13(2)(4), the following subparagraph is added after the second first subparagraph:

‘Distributors shall ensure that radio equipment referred to in Article 3(4) displays and/or is supplied with the label and pictogram and label in accordance with respectively Article 3a(2) and Article 10(8), third subparagraph 5 and 6 when they make such radio equipment available to consumers and other end users. Any visual advertisement organised by or on behalf of for the account of Distributors shall ensure that show the label and the pictogram are displayed close to the price indication when the radio equipment is made available to consumers or other end-users.. If the visual advertisement indicates the price of that radio equipment, the label and the pictogram shall be displayed close to the price indication.’

(4) in Article 17(2), the phrase ‘Article 3(1)’ is replaced by the phrase ‘Article 3(1) and (4)’;

(5) Article 40 is amended as follows:

(a) the title is replaced by the following:

‘Procedure at national level for dealing with radio equipment presenting a risk or not in compliance with essential requirements’;

(b) in paragraph 1, first subparagraph, the words ‘or does not comply with at least one of the applicable essential requirements set out in Article 3’ are added after the words ‘public interest protection covered by this Directive’;

- (6) Article 43(1) is amended as follows:
- (a) in point (h) **is replaced by the following**: ~~the words ‘information on the intended use of radio equipment’ are replaced by the words ‘the mandatory information’~~
‘the information, the EU declaration of conformity or usage restrictions as set out in Article 10(8), (9) and (10) do not accompany the radio equipment or the label and/or the pictogram set out in Article 3a(2) or the label set out in Article 10(8), third subparagraph s 5 and 6 are not displayed or supplied’;
- (b) point (j) is replaced by the following:
‘(j) Article 3a(1) or **Article** 5 is not complied with.’;
- (7) Article 44 is amended as follows:
- (a) in paragraph 2, the following sentence is inserted after the first sentence:
~~‘With respect to delegated acts referred to in Articles 3(4) and Article 10(8), third subparagraph,~~
The power to adopt delegated acts referred to in Article 3(4), Article 3a(2) and in Article 10(8), fifth third-subparagraph shall be is conferred on the Commission for a period of five years from [*OP please insert date of entry into force of this Directive*];
- (b) in paragraphs 3 and 5, the phrase ‘Articles 3(3), 4(2) and 5(2)’ is replaced by the phrase ‘Article 3(3), Article 3(4), **Article 3a(2)**, Article 4(2), Article 5(2), and of Article 10(8), **fifth third-subparagraph**’;
- (c) **the following paragraph is added:**
"3a. Before adopting a delegated act, the Commission shall consult experts designated by each Member State in accordance with the principles laid down in the Interinstitutional Agreement of 13 April 2016 on Better Law-Making".
- (8) the text set out in the Annex to this Directive is inserted as Annex Ia.

Article 2

1. Member States shall adopt and publish, by [***OP please insert date*** – 12 months after the **entry-into-force** ~~adoption~~ of this Directive] at the latest, the laws, regulations and administrative provisions necessary to comply with this Directive. They shall forthwith communicate to the Commission the text of those provisions.

They shall apply those provisions from [***OP please insert date*** – ~~12~~ **24** months after the **entry-into-force of this Directive** ~~end of the transposition period indicated in the preceding subparagraph~~].

When Member States adopt those provisions, they shall contain a reference to this Directive or be accompanied by such a reference on the occasion of their official publication. Member States shall determine how such reference is to be made.

2. Member States shall communicate to the Commission the text of the main provisions of national law which they adopt in the field covered by this Directive.

Article 3

This Directive shall enter into force on the twentieth day following that of its publication in the *Official Journal of the European Union*.

Article 4

This Directive is addressed to the Member States.

Done at Brussels,

For the European Parliament
The President

For the Council
The President

‘ANNEX Ia

Specifications and information in relation to charging applicable to certain categories or classes of radio equipment

PART I

SPECIFICATIONS ON CHARGING CAPABILITIES

1. ~~Hand held mobile phones, tablets, digital **photo/video** cameras **intended for private use**, headphones, headsets, handheld videogame consoles and portable speakers, in so far as they are capable of being recharged via wired charging, shall:~~

~~(a) be equipped with the USB Type C receptacle, as described in the standard EN IEC 62680-1-3:2021 ‘Universal serial bus interfaces for data and power – Part 1-3: Common components – USB Type C™ Cable and Connector Specification’, which should remain accessible and operational at all times;~~

~~(b) be capable, in the case of charging power lower than 60 watts, of being charged with cables which comply with the standard EN IEC 62680-1-3:2021 ‘Universal serial bus interfaces for data and power – Part 1-3: Common components – USB Type C™ Cable and Connector Specification’.~~

2. ~~Hand held mobile phones, tablets, digital **photo/video** cameras intended **for private use**, headphones, headsets, handheld videogame consoles and portable speakers, in so far as they are capable of being recharged via wired charging at voltages higher than 5 volts or currents higher than 3 amperes or powers higher than 15 watts, shall:~~

~~(a) incorporate the USB Power Delivery, as described in the standard EN IEC 62680-1-2:2021 ‘Universal serial bus interfaces for data and power – Part 1-2: Common components – USB Power Delivery specification’;~~

~~(b) ensure that any additional charging protocol allows the full functionality of the USB Power Delivery referred to in point (a).~~

1. **The requirements in points 2 and 3 below shall apply to the following categories or classes of radio equipment:**

a) **hand-held mobile phones,**

b) **tablets,**

c) **digital photo/video cameras not intended for professional ~~private~~ use,**

d) **headphones,**

e) **headsets,**

f) **handheld videogame consoles,**

g) **portable speakers,**

2. **In so far as they are capable of being recharged via wired charging, the categories or classes of radio equipment referred to in point 1 letters a) to g) shall:**
- (a) **be equipped with the USB Type-C receptacle, as described in the standard EN IEC 62680-1-3:2021 ‘Universal serial bus interfaces for data and power - Part 1-3: Common components - USB Type-C®™ Cable and Connector Specification’, which should remain accessible and operational at all times;**
 - (b) **be capable, in the case of charging power lower than 60 watts, of being charged with cables which comply with the standard EN IEC 62680-1-3:2021 ‘Universal serial bus interfaces for data and power - Part 1-3: Common components - USB Type-C®™ Cable and Connector Specification’.**
3. **In so far as they are capable of being recharged via wired charging at voltages higher than 5 volts, currents higher than 3 amperes or powers higher than 15 watts, the categories or classes of radio equipment referred to in point 1 letters a) to g) shall:**
- (a) **incorporate the USB Power Delivery, as described in the standard EN IEC 62680-1-2:2021 ‘Universal serial bus interfaces for data and power - Part 1-2: Common components - USB Power Delivery specification’;(b) **ensure that any additional charging protocol allows the full functionality of the USB Power Delivery referred to in point (a).****

PART II

INFORMATION ON SPECIFICATIONS RELATING TO CHARGING CAPABILITIES AND THE COMPATIBLE CHARGING DEVICES

In the case of radio equipment falling within the scope of Article 3 (4), first subparagraph, the following information shall be indicated **in accordance with the requirements set out in Article 10(8) in printed form on the packaging or, in the absence of packaging, on a label attached to or, where this is not possible, accompanying the radio equipment with the condition that the label can be visible:**

- a) **in the case of all categories or classes of radio equipment which are subject to the requirements of Part I of this Annex**, a description of the power requirements of the wired charging devices that can be used with that radio equipment, including **the minimum power required to charge the radio equipment, and** the maximum power required to charge the radio equipment **at maximum charging speed** expressed in watts by displaying the text: “the minimum power delivered by the charger shall be equal to or higher than [xx] Watts **to charge the radio equipment. The maximum power delivered by the charger shall be equal to or higher than [yy] Watts to achieve maximum charging speed.**” The number of watts should **respectively** express **minimum power required by the radio equipment, and** the maximum power required by the radio equipment **to achieve the maximum charging speed**;
- b) **in the case of radio equipment which is subject to the requirements of point 3 of Part I of this Annex**, a description of the specifications in relation to charging capabilities of the radio equipment, in so far as they are capable of being recharged via wired charging at voltages higher than 5 volts or currents higher than 3 amperes or powers higher than 15 watts, including an indication that the radio equipment supports the USB Power Delivery charging protocol by displaying the text “USB PD fast charging” and an indication of any other supported charging protocol by displaying its name in text format.

~~Such information shall be in a language which can be easily understood by consumers and other end-users, as determined by the Member State concerned, and shall be clear, understandable and intelligible.~~

Part III

PICTOGRAM INDICATING WHETHER OR NOT A CHARGING DEVICE IS OFFERED TOGETHER WITH THE RADIO EQUIPMENT

1. The pPictogram shall have the following format:

The pictogram shall include one of the two following signs:

1.1. If a charging device is offered together with the radio equipment:

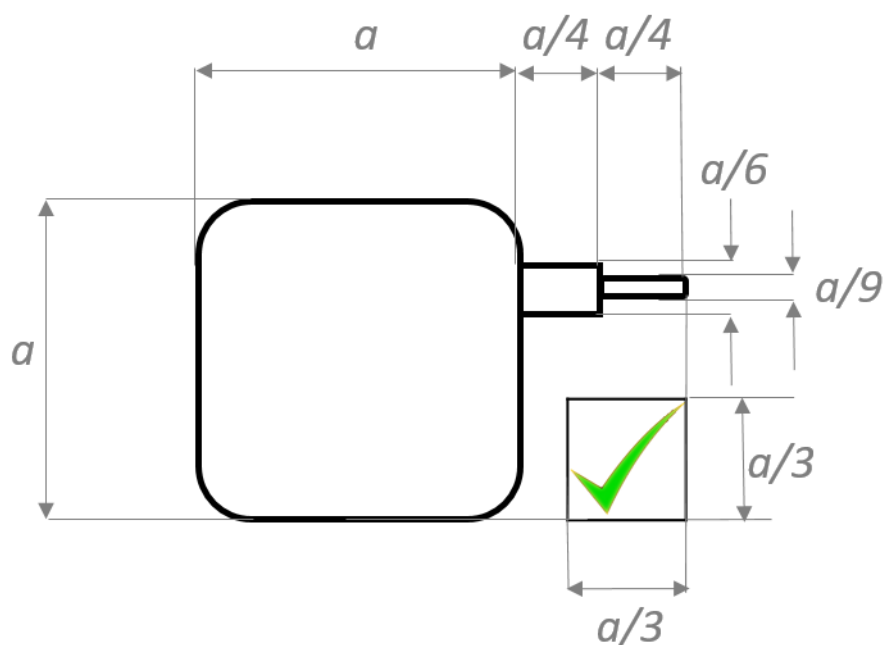

1.2. If no charging device is offered together with the radio equipment:

2. In the pictogram above, the box next to "Yes" shall be checked if a charging device is supplied with the radio equipment while the box next to "No" shall be checked if no charging device is supplied with the radio equipment.

2. In the pictogram above, the box shall be checked with a green mark if a charging device is supplied with the radio equipment, while the box shall remain empty if no charging device is supplied with the radio equipment.

3. The pictogram may take different variations (e.g. colour, solid or hollow, line thickness), provided that it remains visible and legible. If the pictogram is reduced or enlarged, the proportions given in the graduated drawings in point 1 above shall be respected.

CONTENT AND FORMAT OF THE LABEL

1. The label shall have the following format:

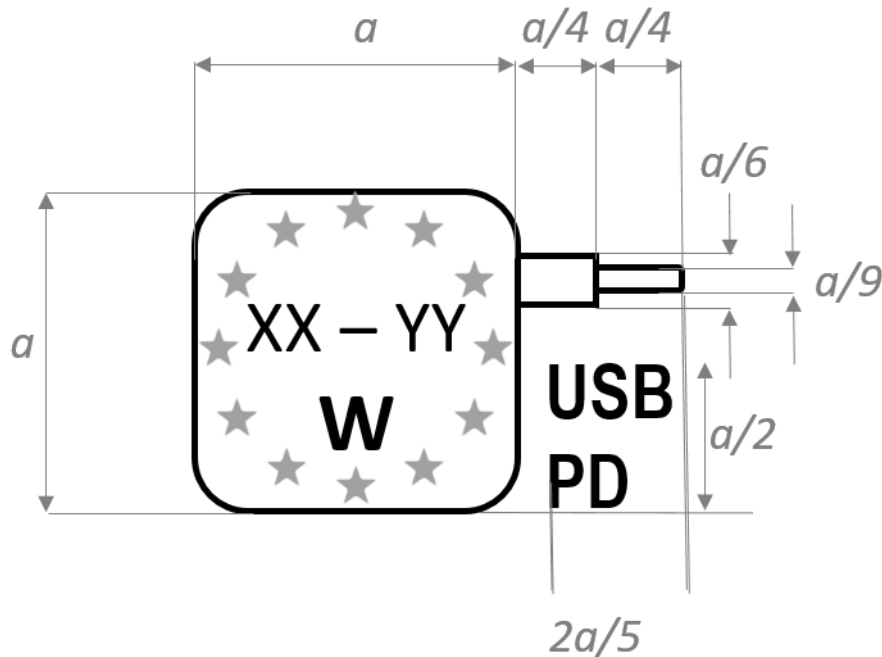

2. The letters "XX" shall be replaced by the figure corresponding to the minimum power required by the radio equipment to charge, which defines the minimum power that a charging device should supply to charge the radio equipment. The letters "YY" shall be replaced by the figure corresponding to the maximum power required by the radio equipment to achieve maximum charging speed, which defines the minimum power that a charging device should at least supply for an optimal charge to achieve that maximum charging speed. The abbreviation "USB PD"(USB Power delivery) shall be displayed if the radio equipment supports this charging communication protocol. "USB PD" is a protocol that negotiates the fastest delivery of current from the charger to the device without shortening the battery lifetime.

3. The label may take different variations (e.g. colour, solid or hollow, line thickness), provided that it remains visible and legible. If the label is reduced or enlarged, the proportions given in the graduated drawing in point 1 above shall be respected.