



Council of the
European Union

Brussels, 15 December 2017
(OR. en)

15685/17

LIMITE

ENT 268
MI 953
CODEC 2063

Interinstitutional File:
2016/0014 (COD)

NOTE

From:	Presidency
To:	Permanent Representatives Committee
No. Cion doc.:	5712/16 ENT 20 MI 45 CODEC 103 + ADD 1 - 4
Subject:	Proposal for a REGULATION OF THE EUROPEAN PARLIAMENT AND OF THE COUNCIL on the approval and market surveillance of motor vehicles and their trailers, and of systems, components and separate technical units intended for such vehicles - Analysis of the final compromise text with a view to agreement

I. INTRODUCTION

1. The Commission transmitted this proposal to the Council on 28 January 2016.
2. In the European Parliament, this proposal was referred to the Internal Market and Consumer Protection (IMCO) Committee which appointed Mr Daniel Dalton (UK, ECR) as rapporteur. IMCO voted its report on 9 February 2017. This vote was confirmed at the EP Plenary Meeting of 4 April 2017.

3. Following a thorough examination by the Working Party on Technical Harmonisation (Motor Vehicles) under the Dutch, Slovak and Maltese Presidencies, the Council (Competitiveness) agreed a General Approach¹ on 29 May 2017 and mandated the Presidency to begin negotiations with the European Parliament with a view to reaching an agreement in first reading.
4. During the Estonian Presidency a total of four trilogue meetings were conducted. The trilogues took place on 6 September, 10 October, 23 November and 7 December 2017. They were preceded by a number of tripartite technical meetings to prepare for the trilogues.
5. At the fourth trilogue on 7 December, both co-legislators reached a provisional agreement.

II. STATE OF PLAY

6. The tentative agreement reached at the fourth trilogue concerned a few remaining outstanding issues, namely:
 - The obligations of market surveillance authorities (Article 8);
 - The assessments by the Commission of the procedures put in place by the authorities that have granted EU type approvals (Article 9a) and the corresponding recital;
 - The penalties and administrative fines (Articles 89 and 90);
 - The transitional period and the dates of entry into force and application of the Regulation;
 - The empowerment for the Commission to lay down implementing acts, except for the determination of criteria of sanctions for Article 90, where the Presidency had to accept to turn the proposed implementing acts into a delegated act in the context of an overall agreement.
 - Finally, a new recital on defeat devices reflecting the already agreed text in the main body of the Regulation (recital 25a), as well as a slightly modified recital on data provision rules (recital 43).

¹ 9867/17

7. Coreper was informed on 8 December 2017 of the provisional agreement reached at the fourth trilogue on 7 December 2017, which is generally in line with the negotiation mandate given to the Presidency by Coreper on 6 December 2017. In the meeting of the Working Party on Technical Harmonisation (Motor Vehicles) which took place on 11 December 2017, delegations showed willingness to support the agreement, subject to minor modifications on several recitals. The EP had no objections to the latter. The provisional agreement was also supported by the Commission.

III. OUTSTANDING ISSUES

8. Following the tentative agreement at the last trilogue there are no more outstanding issues between the Council and the European Parliament.

IV. CONCLUSION

9. The Permanent Representatives Committee is invited to endorse the compromise text and to mandate the Presidency to inform the European Parliament that, should the Parliament adopt the text of the Proposal in the exact form as set out in the Annex - subject to legal-linguistic revision- at a forthcoming plenary meeting, the Council would adopt the proposed Regulation thus amended.

REGULATION (EU) 2018/...

OF THE EUROPEAN PARLIAMENT AND OF THE COUNCIL

of ...

on the approval and market surveillance of motor vehicles and their trailers, and of systems, components and separate technical units intended for such vehicles

(Text with EEA relevance)

THE EUROPEAN PARLIAMENT AND THE COUNCIL OF THE EUROPEAN UNION,

Having regard to the Treaty on the Functioning of the European Union, and in particular Article 114 thereof,

Having regard to the proposal from the European Commission,

After transmission of the draft legislative act to the national parliaments,

Having regard to the opinion of the European Economic and Social Committee²,

Acting in accordance with the ordinary legislative procedure³,

Whereas:

- (1) The internal market comprises an area without internal frontiers in which the free movement of goods, persons, services and capital must be ensured. Internal market rules should be transparent, simple, consistent and effective, thus providing legal certainty and clarity for the benefit of businesses and consumers.

² OJ C 303, 19.8.2016, , , p. 86.

³ Position of the European Parliament of ... (not yet published in the Official Journal) and decision of the Council of

- (2) To that end, a comprehensive EU type-approval framework for motor vehicles and their trailers, and of systems, components and separate technical units intended for such vehicles, was established by Directive 2007/46/EC of the European Parliament and of the Council⁴.
- (3) An assessment of the Union legal framework for the type-approval of motor vehicles and their trailers, and of systems, components and separate technical units intended for such vehicles, carried out in 2013⁵, showed that the framework established by Directive 2007/46/EC is appropriate for achieving the main goals of harmonisation, effective operation of the internal market and fair competition, and therefore should continue to apply.
- (4) In that assessment it was concluded, however, that there is a need to introduce market surveillance provisions to complement the type-approval requirements, a need to clarify the recall and safeguard procedures, as well as the conditions for granting extensions to approvals for existing types of vehicle, a need to improve the enforcement of the type-approval framework by harmonising and enhancing the type-approval and conformity of production procedures applied by Member States' authorities and technical services, a need to clearly delineate the roles and responsibilities of economic operators in the supply chain, and of the authorities and parties involved in the enforcement of the framework, guaranteeing the independence of those authorities and parties, and preventing conflicts of interest, and a need to improve the suitability of alternative type-approval schemes (national small series and individual vehicle approvals) and of the multi-stage type-approval process to provide appropriate flexibility for niche markets and SMEs, without however distorting the level playing field.

⁴ Directive 2007/46/EC of the European Parliament and of the Council of 5 September 2007 establishing a framework for the approval of motor vehicles and their trailers, and of systems, components and separate technical units intended for such vehicles (Framework Directive)(OJ L 263, 9.10.2007, p. 1).

⁵ Commission Staff Working Document 'Fitness Check of the EU legal framework for the type-approval of motor vehicles' (SWD(2013) 466 final).

- (5) In addition, recent problems encountered with the implementation of the type-approval framework have revealed particular weaknesses and demonstrate the need for a fundamental revision to ensure a robust, transparent, predictable and sustainable regulatory framework that provides a high level of safety and of health and environmental protection.
- (5a) This Regulation introduces many safeguards to prevent misapplication of the requirements imposed in the process of granting approval to vehicles, systems, components or other separate technical units. It is important that these safeguards are effective in order to avoid abuse of the approvals process in the future.
- (6) This Regulation sets out the harmonised rules and principles for the type-approval of motor vehicles and their trailers, and of systems, components and separate technical units intended for such vehicles, and the individual vehicle approval, with a view to ensuring the proper functioning of the internal market for the benefit of businesses and consumers and to offer a high level of safety and protection of health and the environment.

- (7) This Regulation lays down the substantive technical and administrative type-approval requirements for motor vehicles of categories M and N and their trailers (category O), and for the systems, components and separate technical units intended for such vehicles with a view to ensuring a high level of safety and environmental performance. These categories cover motor vehicles for the carriage of passengers, motor vehicles for the carriage of goods, and their trailers, respectively.
- (7a) National approval authorities should apply and enforce the requirements of this Regulation in a uniform manner across the Union to ensure a level playing field and to avoid application of divergent standards across the Union. They should fully cooperate with the Forum and the Commission in its audit and oversight activities.
- (8) This Regulation should strengthen the current type-approval framework, in particular through the introduction of provisions on market surveillance. Market surveillance in the automotive sector should be introduced by specifying the obligations of the economic operators in the supply chain, the responsibilities of the enforcement authorities in the Member States, and the measures to be taken when automotive products are encountered on the market that represent serious safety or environmental risks, endanger protection of consumers, or that do not comply with the type-approval requirements.

- (9) An effective implementation of the type-approval requirements should be ensured by enhancing the provisions on conformity of production by, inter alia, providing for mandatory periodic audits of the conformity control methods and the continued conformity of the products concerned and by reinforcing the requirements relating to the competence, obligations and performance of the technical services that carry out tests for whole-vehicle type-approval under the responsibility of type-approval authorities. The proper functioning of technical services is crucial for ensuring a high level of safety and environmental protection and citizens' confidence in the system. The criteria for designation of technical services provided by Directive 2007/46/EC should be laid down in greater detail in order to ensure that they are applied consistently across all Member States. The assessment methods of technical services in the Member States tend to progressively differ due to the increased complexity of their work. Therefore, it is necessary to provide for procedural obligations that ensure an information exchange and monitoring of Member States' practices for the assessment, designation, notification and monitoring of their technical services. Those procedural obligations should remove any existing discrepancies in the methods used and in the interpretation of the criteria for the designation of technical services. In order to ensure adequate oversight and a level playing-field across the Union, the assessment of an applicant technical service should include an on-site assessment.
- (9a) In case of multi-stage type-approval, it is essential to verify that changes made before the final stage of completion have not affected the functioning of approved systems, components or separate technical units in a way that would invalidate the type approval previously granted.

- (10) The need for control and monitoring of technical services has increased since technical progress has raised the risk that technical services do not possess the necessary competence to test new technologies or devices emerging within their scope of designation. As technical progress shortens product cycles and as the intervals of surveillance on-site assessments and of the monitoring vary, the validity of the designation of technical services should be limited in time, which should ensure a periodic assessment of the competence of technical services.
- (11) Designation and monitoring of technical services by the Member States, in accordance with detailed and strict criteria, should therefore be subject to supervisory controls at Union level, including independent audits as a condition for the renewal of their notification. The position of technical services vis-à-vis manufacturers should be strengthened, including their right and duty to carry out unannounced factory inspections and to conduct physical or laboratory tests on products covered by this Regulation, in order to ensure continuous compliance by manufacturers after they have obtained a type-approval for their products.
- (12) In order to increase transparency and mutual trust and to further align and develop the criteria for the assessment, designation, and notification of technical services, as well as extension and renewal procedures, Member States should cooperate with each other and with the Commission. They should consult each other and the Commission on questions with general relevance for the implementation of this Regulation and inform each other and the Commission. It is important that the Member States and the Commission use common electronic exchange systems as a means to facilitate and enhance administrative cooperation after appropriate implementation periods in order to make the management of the exchange of information more efficient and effective on the basis of simple and unified procedures. In order to facilitate its accessibility and transparency, information should be available as structured data that is electronically searchable.

- (13) Where designation of a technical service is based on accreditation in the meaning of Regulation (EC) No 765/2008 of the European Parliament and of the Council⁶, accreditation bodies and designating authorities should exchange information relevant for the assessment of the competence of technical services.
- (14) The Member States should levy fees for the designation and monitoring of technical services to ensure sustainability of the monitoring of those technical services by Member States and to establish a level playing field for technical services.
- (15) When, in spite of the measures taken to ensure a coherent application and follow up of the requirements by the Member States, the competence of a technical service is in doubt, the Commission should have the possibility to investigate individual cases.
- (16) In order to ensure that tests and reports provided by technical services are not influenced by non-legitimate circumstances, the organisation and operation of technical services should ensure full impartiality and independence. To be able to carry out their tasks in a coherent and systematic manner, the technical services should possess a satisfactory management system including provisions on professional secrecy. In order to allow technical services to perform their work properly, the level of knowledge, competence and independence of their personnel should be guaranteed at all times.
- (17) [...]
- (18) A robust compliance enforcement mechanism is necessary in order to ensure that the requirements under this Regulation are met. Ensuring compliance with the type-approval and conformity of production requirements of the legislation governing the automotive sector should remain the key responsibility of the approval authorities, as it is an obligation closely linked to the issuing of the type-approval and requires detailed knowledge of its content. It is therefore important that the performance of approval authorities is regularly verified.

⁶ Regulation (EC) No 765/2008 of the European Parliament and of the Council of 9 July 2008 setting out the requirements for accreditation and market surveillance relating to the marketing of products and repealing Regulation (EEC) No 339/93 (OJ L 218, 13.8.2008, p. 30).

- (18a) In order to ensure compliance with this Regulation, to ensure its uniform application within the Union and to facilitate an exchange of best practices, the Commission should organise and carry out assessments of the procedures set up by type-approval authorities in the application of this Regulation. The outcome of such assessment, including any non-binding recommendations, should be discussed within the Forum. The assessments should be carried out periodically, while taking into account the principle of proportionality, the number and variety of type approvals granted and any non-compliances discovered during the compliance verification.
- (18b) In order to ensure the effectiveness of the Commission assessment while minimising the administrative burden, it is important that the type-approval authorities and the Commission cooperate efficiently during the assessment, in particular during the on-site assessment. The Commission assessments should be carried out in compliance with the national law, for example following the working periods or language of the authorities. The costs arising from those assessments should be borne by the Commission, including those related to document translation.
- (18c) The compliance verification system is being strengthened by the recognition of a formal process of accreditation of technical services or via the introduction of regular peer-evaluation in respect of the assessment and monitoring of technical services by type approval-authorities. This aims at ensuring that a uniform level of quality and stringency is applied by all approval authorities in enforcing the type-approval requirements.

- (19) Closer coordination between national authorities through information exchange and coordinated assessments under the direction of a coordinating authority is fundamental for ensuring a consistently high level of safety and health and environmental protection within the internal market. This should also lead to more efficient use of scarce resources at national level. For this purpose an advisory Forum should be established for Member States and the Commission with the objective to promote good practices, to exchange information and to coordinate activities related to the enforcement of type-approval legislation. The currently informal cooperation between Member States in this respect would benefit from a more formal framework. This Forum should be composed of representatives appointed by the Member States representing the type-approval authorities and the market surveillance authorities. The representatives attending a given meeting should be selected on the basis of the issues discussed by the Forum. In order to benefit from a range of views and inputs, it is useful that particular outside observers are invited on a regular basis to the Forum, whenever those observers' activities are relevant to the issues discussed in the Forum.
- (19a) Type approval authorities and market surveillance authorities should not be linked when carrying out their tasks, so as to avoid potential conflicts of interest. Where a Member State chooses to place those authorities under the remit of a single organisation, it should at least ensure that the organisational structures ensure that the activities are distinct from the other in terms of direct management and decision-making.
- (20) The rules on Union market surveillance and control of products entering the Union market provided for in Regulation (EC) No 765/2008 apply to motor vehicles and their trailers, and to systems, components and separate technical units intended for such vehicles without preventing Member States from choosing the competent authorities to carry out those tasks. Market surveillance may be a competence shared between different national authorities to take account of the national market surveillance systems in the Member States established under Regulation (EC) No 765/2008. Effective coordination and monitoring at Union and national levels should guarantee that approval and market surveillance authorities enforce the new type-approval and market surveillance framework.

- (21) It is necessary to include rules on market surveillance in this Regulation in order to reinforce the rights and obligations of the national competent authorities, to ensure effective coordination of their market surveillance activities and to clarify the applicable procedures.
- (21a) It is necessary that the market surveillance authorities and the type-approval authorities can properly perform the tasks provided for by this Regulation. Member States should in particular equip them with the resources necessary for that purpose.
- (22) In order to increase transparency in the approval process and facilitate the exchange of information and the independent verification by market surveillance authorities, approval authorities and the Commission, type approval documentation should be provided in electronic format and be made publicly available, subject to exemptions due to protection of commercial interests and the protection of personal data.
- (23) The obligations of national authorities concerning market surveillance provided in this Regulation are more specific than those laid down in Article 19 of Regulation (EC) No 765/2008 to take account of the specificities of the type-approval framework and the need to complement that framework with an effective market surveillance mechanism ensuring a robust verification of compliance of the products covered by this Regulation. In order to ensure the functioning of the framework, it is essential that market surveillance ensure the verification of compliance of the products irrespective of whether their type-approval was granted before or after the date of application of this Regulation.
- (23a) The compliance verification of vehicles, systems, components and separate technical units on the market based on a robust risk-assessment is essential for the proper functioning of market surveillance. This, complemented with the establishment of a minimum number of checks on vehicles per year should contribute towards an effective Union-wide implementation of the market surveillance obligations.

- (23b) In view of the specificities and the potential risk linked to emissions, an adequate share of the minimum number of checks should be apportioned to emissions testing. In order to ensure the full compliance of the vehicles, each single check should encompass verifying that all the requirements for type-approval as regards emissions that are applicable to the vehicle being tested are met.
- (23c) Any tests carried out on any vehicle in any Member State may be used for the purpose of taking corrective and restrictive measure in an another Member State. The results of the checks performed on vehicles within a Member State should be considered adequate for the purpose of invoking corrective and restrictive measures in an another Member State. Therefore, the physical transportation of the concerned vehicles should not be required for the purpose of any checks which are carried out on behalf of another Member State.
- (24) It is of particular importance that national authorities and the Commission consider, as part of their compliance verification, in-service conformity testing and inspections of vehicles. The selection of the vehicles to be subject to this ex-post compliance verification should be based on an appropriate risk assessment which takes account of the seriousness of the possible non-compliance, the likelihood of its occurrence and other possible indicators such as the introduction of vehicles with new technology installed, any past history or reports of non-compliance, results of remote sensing testing and concerns expressed by recognised third parties.

(25) In addition, the Commission should organise and carry out compliance verification tests and inspections, independent from those carried out by Member States under their national market surveillance obligations, in order to verify compliance with the relevant requirements.

Where such tests take place on registered vehicles in agreement with the holder of the vehicle registration certificate, it is important to take into account the fact that modified vehicles may not be suitable to verify such compliance. It is also important to take into account the implications for the holder of the vehicle registration certificate, especially in case of a natural person, for which the suitable ways of selecting the vehicles are via public call or via the Member States' authorities. When non-compliance is established by those tests and inspections, or where it is found that a type approval has been granted on the basis of incorrect data, the Commission should be entitled to initiate Union-wide remedial actions to restore the conformity of the vehicles concerned and to investigate the reasons for the incorrectness of the type approval. Appropriate funding should be ensured in the general budget of the Union to enable the execution of such compliance verification testing and inspections.

- (25a) For the purpose of supporting Member States in detecting defeat devices, the Commission published, on 26 January 2017, Guidance on the evaluation of Auxiliary Emission Strategies and the presence of Defeat Devices. Consistent with the provisions of that Guidance, the test activities of the Commission, type-approval authorities and technical services for the purpose of detecting defeat devices should remain non-predictable in character, also including modified testing conditions which entail variations in physical conditions and testing parameters.
- (26) In order to ensure a high level of vehicle functional safety, the protection of vehicle's occupants and other road users, and environmental and health protection, the technical requirements and environmental standards applicable to vehicles, systems, components and separate technical units should continue to be harmonised and adapted to technical and scientific progress.
- (27) The objectives of this Regulation should not be affected by the fact that certain systems, components, separate technical units or parts and equipment can be fitted to or in a vehicle after that vehicle has been placed on the market, registered or entered into service. Appropriate measures should therefore be taken to ensure that the systems, components, separate technical units or parts and equipment that can be fitted to or in vehicles and that can significantly impair the functioning of systems that are essential for environmental protection or functional safety are controlled by an approval authority before they are placed on the market, registered or entered into service.
- (27a) These measures should only apply to a limited number of parts or equipment. The list of such parts or equipment and subsequent requirements should be established as a matter of priority by the Commission in case of serious risk, after having consulted stakeholders, ensuring in particular that replacement parts and equipment that are essential for emission controls and safety meet the performance specifications of the original parts and equipment. In establishing the list, the Commission should consult stakeholders on the basis of a report and strive for a fair balance between the requirements of improving road safety and environmental protection, as well as the interests of consumers, manufacturers and distributors in preserving competition in the aftermarket.

- (28) The EU type-approval system has to enable each Member State to confirm that every type of vehicle and every type of system, component and separate technical unit intended for such type of vehicle has undergone the tests and inspections provided for in this Regulation to verify its compliance with the type-approval requirements of this Regulation and that its manufacturer has obtained a type-approval certificate for it. The EU type-approval system obliges a manufacturer to produce his vehicles, systems, components and separate technical units in conformity with the approved type. A vehicle manufacturer has to certify this by issuing a certificate of conformity for every vehicle. Every vehicle accompanied by a valid certificate of conformity should be permitted to be made available on the market and registered for use throughout the Union.
- (28a) In order to simplify the exchange of type approval related information between competent authorities and make the relevant information publically accessible, after appropriate implementation periods, searchable online databases should be used on a compulsory basis. To preserve confidential data, it is important that all data exchange should be performed by means of secure data exchange protocols. Special attention should be made to eliminate data misuse, for example to avoid multiple first time registrations when using certificates of conformity in electronic form.
- (29) Conformity of production is one of the cornerstones of the EU type-approval system, and therefore the arrangements set up by the manufacturer to ensure such conformity should be approved by the competent authority or by an appropriately qualified technical service designated for that purpose, and be subject to regular verification by means of independent periodic audits. In addition, approval authorities should ensure the verification of the continued conformity of the products concerned.

- (30) The continued validity of the type-approvals requires that the manufacturer informs the authority that has approved his type of vehicle about any changes to the characteristics of the type or the safety and environmental performance requirements applicable to that type so that it can be verified that the type of vehicle continues to comply with all the applicable requirements. Furthermore, the conditions for amending type-approvals should be clarified to ensure a uniform application of the procedures and enforcement of the type-approval requirements throughout the Union, in particular to ensure strict application of the rules that distinguish between amended type-approvals and new type approvals. In addition to the provisions of this Regulation, to ensure that the latest requirements will be implemented on all new vehicles at a certain point in time, it is important that regulatory acts listed in Annex IV include not only a date for the application of new requirements to new type-approvals, but also a date from which new requirements become mandatory for the making available on the market, registration or entry into service of vehicles, system, component or separate technical unit.
- (31) The assessment of reported serious risks to safety and of harm to public health and the environment should be conducted at national level, but coordination at Union level should be ensured where the reported risk or harm may exist beyond the territory of one Member State with the objective of sharing resources and ensuring consistency regarding the corrective action to be taken to mitigate the identified risk and harm.

- (32) In order to ensure that all vehicles, systems, components and separate technical units placed on the market offer a high level of safety and environmental protection, the manufacturer or any other economic operator in the supply chain should take effective corrective measures, including the recall of vehicles, where a vehicle, system, component or separate technical unit presents a serious risk for users or the environment as referred to in Article 20 of Regulation (EC) No 765/2008. Approval authorities should be empowered to assess and verify whether those measures are sufficient. The authorities of other Member States' should have the right to take safeguard measures in case they would consider that the manufacturer's corrective measures are not sufficient.
- (32a) In case corrective measures are applied, holders of registrations for affected vehicles should not bear the costs of the repairs to their vehicles, including cases where repairs have been carried out at the registration holder's expense prior to the corrective measure being adopted. This should not preclude the possibility for consumers to rely on remedies based on contractual law, as applicable according to Union or national legislation.
- (33) Appropriate flexibility should be provided by means of alternative type-approval schemes for manufacturers who produce vehicles in small series. They should be able to benefit from the advantages of the Union internal market provided that their vehicles comply with the specific EU type-approval requirements for vehicles produced in small series. In certain limited cases, it is appropriate to allow for national small series type-approval. In order to prevent misuse, any simplified procedure for vehicles produced in small series should be restricted to cases of very limited production in accordance with this Regulation. It is therefore necessary to define precisely the concept of vehicles produced in small series in terms of the number of vehicles produced, the requirements to be complied with and the conditions for placing those vehicles on the market. It is equally important to specify an alternative approval scheme for individual vehicles, in particular to provide sufficient flexibility for the approval of vehicles built in multiple stages.

- (34) The Union is a contracting party to the Agreement of the United Nations Economic Commission for Europe (UNECE) concerning the adoption of uniform technical prescriptions for wheeled vehicles, equipment and parts which can be fitted to and/or be used on wheeled vehicles and the conditions for reciprocal recognition of approvals granted on the basis of these prescriptions ('Revised 1958 Agreement')⁷. The Union has accepted a significant number of regulations annexed to the Revised 1958 Agreement and has therefore the obligation to accept type-approvals issued in accordance with those regulations, as complying with the equivalent Union requirements. For the purpose of simplifying its type-approval framework and aligning it with the international framework of the UNECE, the Union in Regulation (EC) No 661/2009 of the European Parliament and of the Council⁸ repealed its specific type-approval Directives and replaced them with the obligatory application of the relevant UNECE regulations. To reduce the administrative burden of the type-approval process, manufacturers of vehicles, systems, components and separate technical units should be allowed to seek type-approval in accordance with this Regulation, where appropriate, directly by means of obtaining approval under the relevant UNECE regulations referred to in the Annexes to this Regulation.
- (35) Consequently, UNECE regulations and the amendments thereto which the Union has voted in favour of or that the Union applies, in accordance with Council Decision 97/836/EC⁹, should be incorporated within the EU type-approval legislation. Accordingly, the power should be delegated to the Commission to amend the Annexes to this Regulation and to adopt delegated acts to ensure that the references to the UNECE regulations and their respective amendments in the list of the relevant regulatory acts are kept up-to-date.

⁷ Council Decision 97/836/EC of 27 November 1997 with a view to accession by the European Community to the Agreement of the United Nations Economic Commission for Europe concerning the adoption of uniform technical prescriptions for wheeled vehicles, equipment and parts which can be fitted to and/or be used on wheeled vehicles and the conditions for reciprocal recognition of approvals granted on the basis of these prescriptions ('Revised 1958 Agreement') (OJ L 346, 17.12.1997, p. 81).

⁸ Regulation (EC) No 661/2009 of the European Parliament and of the Council of 13 July 2009 concerning type-approval requirements for the general safety of motor vehicles, their trailers and systems, components and separate technical units intended therefor (OJ L 200, 31.7.2009, p. 1).

⁹ Council Decision 97/836/EC of 27 November 1997 (OJ L 346, 17.12.1997, p. 78).

- (36) Unrestricted access to vehicle repair and maintenance information, via a standardised format that can be used to retrieve the technical information, and effective competition on the market for services providing such information is necessary to improve the functioning of the internal market, particularly as regards the free movement of goods, the freedom of establishment and the freedom to provide services. The requirements for the provision of repair and maintenance information have so far been laid down in Regulation (EC) No 715/2007 of the European Parliament and of the Council¹⁰ and Regulation (EC) No 595/2009 of the European Parliament and of the Council¹¹. Those requirements should be consolidated in this Regulation and Regulations (EC) No 715/2007 and (EC) No 595/2009 should be amended accordingly.
- (37) Whereas technical progress introducing new methods or techniques for vehicle diagnostics and repair, such as remote access to vehicle information and software, should not weaken the objectives of this Regulation with respect to access to repair and maintenance information for independent operators.

¹⁰ Regulation (EC) No 715/2007 of the European Parliament and of the Council of 20 June 2007 on type approval of motor vehicles with respect to emissions from light passenger and commercial vehicles (Euro 5 and Euro 6) and on access to vehicle repair and maintenance information (OJ L 171, 29.6.2007, p. 1).

¹¹ Regulation (EC) No 595/2009 of the European Parliament and of the Council of 18 June 2009 on type-approval of motor vehicles and engines with respect to emissions from heavy duty vehicles (Euro VI) and on access to vehicle repair and maintenance information and amending Regulation (EC) No 715/2007 and Directive 2007/46/EC and repealing Directives 80/1269/EEC, 2005/55/EC and 2005/78/EC (OJ L 188, 18.7.2009, p. 1).

- (37a) In order to ensure effective competition on the market for vehicle repair and maintenance information services, and in order to clarify that the information concerned also covers information which needs to be provided to independent operators, so as to ensure that the independent vehicle repair and maintenance market as a whole can compete with authorised dealers, regardless of whether the vehicle manufacturer gives such information to authorised dealers and repairers directly or provides the repair and maintenance itself, it is necessary to set out the details of the information to be provided for the purposes of access to vehicle repair and maintenance information.
- (37aa) For the inspection of vehicles, and especially for their safety and environment related components, it has been considered necessary for testing centres and relevant competent authorities to have access to the technical specifications of each individual vehicle as set out in Article 4 of Directive 2014/45/EU. In order to facilitate the compliance with the requirements laid down in that Directive, the independent operators should have access to the relevant technical information needed for the preparation of vehicles for road worthiness testing.
- (37b) Since there is currently no common structured process for the exchange of vehicle component data between vehicle manufacturers and independent operators, it is appropriate to develop principles for such an exchange of data. A future common structured process on the standardised format of the data exchanged should be developed by the European Committee for Standardization (CEN) formally, whereupon the mandate given to CEN does not predetermine the level of detail this standard will provide. The CEN's work should, in particular, reflect the interests and needs of vehicle manufacturers and independent operators alike and should also investigate solutions such as open data formats described by well defined meta-data to accommodate existing IT infrastructures.

- (38) In order to ensure uniform conditions for the implementation of this Regulation, implementing powers should be conferred on the Commission. Those powers should be exercised in accordance with Regulation (EU) No 182/2011 of the European Parliament and of the Council¹².
- (39) In order to ensure the effectiveness of this Regulation, the power to adopt acts in accordance with Article 290 of the Treaty on the Functioning of the European Union should be delegated to the Commission in respect of type-approval requirements concerning the environmental and safety performance of motor vehicles and their trailers, and of systems, components and separate technical units for such vehicles. It is of particular importance that the Commission carry out appropriate consultations during its preparatory work, and that those consultations be conducted in accordance with the principles laid down in the Interinstitutional Agreement on Better Law-Making of 13 April 2016. In particular, to ensure equal participation in the preparation of delegated acts, the European Parliament and the Council receive all documents at the same time as Member States' experts, and their experts systematically have access to meetings of Commission expert groups dealing with the preparation of delegated acts.
- (40) Member States should lay down rules on penalties for the infringements of this Regulation and ensure that those rules are implemented. Those penalties should be effective, proportionate and dissuasive, reflecting in particular the risk to safety or health or the environmental risk that the number of non-compliant vehicles, systems, components or separate technical units made available on the market could pose. Member States shall report the imposed penalties to the Commission annually, to monitor the coherence of the implementation of these provisions.

¹² Regulation (EU) No 182/2011 of the European Parliament and of the Council of 16 February 2011 laying down the rules and general principles concerning mechanisms for control by Member States of the Commission's exercise of implementing powers (OJ L 55, 28.2.2011, p. 13).

- (40a) When performing compliance verification testing, technical services should be able to choose the parameters of the tests freely and in a non-predictable manner within the range provided in the relevant regulatory acts. This should help them verify that the vehicles tested are compliant in the whole range of parameters, including the parameters that correspond to the worst case for the test.
- (40b) In order to ensure that the vehicles, systems, components and separate technical units comply with this Regulation in all cases, they should be deemed not to comply with the relevant requirements when test results cannot be empirically verified by the relevant authority when all testing parameters are replicated or taken into account. It is necessary to impose penalties on economic operators and technical services who falsify test results or submit false declarations or incorrect data for type-approval.
- (41) In the interests of clarity, rationality and simplification, Directive 2007/46/EC should be repealed and replaced by this Regulation. The adoption of a Regulation ensures that provisions are directly applicable and that they can be updated in a timely and more efficient manner to take better account of technical progress and regulatory developments in the context of the Revised 1958 Agreement.
- (42) In order to support corrective and restrictive measures at EU level, the Commission should be competent to impose harmonized administrative fines upon the economic operators found to have infringed upon this regulation regardless of where the vehicle, system, component or separate technical unit was originally type-approved. The Commission should lay down the procedure, methods for calculation and collection of those administrative fines to supplement the principles laid down in this Regulation.

- (43) Whenever the measures provided for in this Regulation entail the processing of personal data, they should be carried out in accordance with Regulation (EU) 2016/679 of the European Parliament and of the Council and Regulation (EC) No 45/2001 of the European Parliament and of the Council¹³, as well as the national implementing measures thereto. It is important that manufacturers implement all necessary measures to comply with the rules on processing and transmission of personal data that is generated while the vehicle is used.
- (44) In order to enable Member States and national authorities as well as economic operators to prepare for the application of the new rules introduced by the act, an application date following the entry into force should be set.
- (45) Since the objectives of this Regulation, namely to lay down harmonised rules on the administrative and technical requirements for the type-approval of vehicles of categories M, N and O, and of systems, components and separate technical units, and on market surveillance of such vehicles, systems, components and separate technical units, cannot be sufficiently achieved by the Member States, but can rather, by reason of their scale and effects, be better achieved at Union level, the Union may adopt measures in accordance with the principle of subsidiarity as set out in Article 5 of the Treaty on European Union. In accordance with the principle of proportionality, as set out in that Article, this Regulation does not go beyond what is necessary in order to achieve those objectives,

HAVE ADOPTED THIS REGULATION:

¹³ Regulation (EC) No 45/2001 of the European Parliament and of the Council of 18 December 2000 on the protection of individuals with regard to the processing of personal data by the Community institutions and bodies and on the free movement of such data (OJ L 8, 12.1.2001, p. 1).

CHAPTER I

SUBJECT MATTER, SCOPE AND DEFINITIONS

Article 1 *Subject matter*

1. This Regulation establishes the administrative provisions and technical requirements for the type-approval and placing on the market of all new vehicles, systems, components and separate technical units referred to in Article 2(1). It also applies to individual vehicle approvals.

This Regulation also establishes the provisions for the placing on the market and entry into service of parts and equipment that may pose a serious risk to the correct functioning of essential systems of vehicles referred to in Article 2(1).

2. This Regulation establishes the requirements for the market surveillance of vehicles, systems, components and separate technical units that are subject to approval, as well as of parts and equipment for such vehicles.

Article 2 *Scope*

1. This Regulation shall apply to motor vehicles of categories M and N and their trailers of category O, that are intended to be used on public roads, including those designed and constructed in one or more stages, and to systems, components and separate technical units, as well as to parts and equipment, designed and constructed for such vehicles and trailers.
2. This Regulation does not apply to the following vehicles:
 - (a) agricultural or forestry vehicles, as defined in Regulation (EU) No 167/2013 of the European Parliament and of the Council¹⁴;

¹⁴ Regulation (EU) No 167/2013 of the European Parliament and of the Council of 5 February 2013 on the approval and market surveillance of agricultural or forestry vehicles (OJ L 60, 2.03.2013, p. 1).

- (b) two- or three-wheel vehicles and quadricycles, as defined in Regulation (EU) No 168/2013 of the European Parliament and of the Council¹⁵;
 - (c) track-laying vehicles;
 - (d) vehicles designed and constructed or adapted for use by the armed services only.
3. For the following vehicles, the manufacturer may apply for type-approval or individual vehicle approval under this Regulation, provided that those vehicles fulfil the requirements of this Regulation:
- (a) vehicles designed and constructed for use principally on construction sites or in quarries, port or airport facilities;
 - (b) vehicles designed and constructed or adapted for use by civil protection, fire services and forces responsible for maintaining public order;
 - (c) any self-propelled vehicle designed and constructed specifically to perform work and that, because of its construction characteristics, is not suitable for carrying passengers or for transporting goods, and which is not machinery mounted on a motor vehicle chassis.

Such approvals shall be without prejudice to the application of Directive 2006/42/EC of the European Parliament and of the Council of 17 May 2006 on machinery.

4. For the following vehicles, the manufacturer may apply for individual vehicle approval under this Regulation:
- (a) vehicles intended exclusively for racing on roads;
 - (b) prototypes of vehicles used on the road under the responsibility of a manufacturer to perform a specific test programme provided they have been specifically designed and constructed for that purpose.

¹⁵ Regulation (EU) No 168/2013 of the European Parliament and of the Council of 15 January 2013 on the approval and market surveillance of two- or three-wheel vehicles and quadricycles (OJ L 60, 2.03.2013, p. 52).

Article 3
Definitions

For the purposes of this Regulation and the regulatory acts listed in Annex IV, save as otherwise provided therein, the following definitions shall apply:

- (1) ‘type-approval’ means the procedure whereby an approval authority certifies that a type of vehicle, system, component or separate technical unit satisfies the relevant administrative provisions and technical requirements;
- (2) ‘market surveillance’ means the activities carried out and measures taken by the market surveillance authorities to ensure that vehicles, systems, components or separate technical units as well as parts and equipment made available on the market comply with the requirements set out in the relevant Union harmonisation legislation and do not endanger health, safety, the environment or any other aspect of public interest protection;
- (3) ‘vehicle’ means any motor vehicle or its trailer as defined in points (10) and (11);
- (4) ‘system’ means an assembly of devices combined to perform one or more specific functions in a vehicle and that is subject to the requirements of this Regulation or any of the regulatory acts listed in Annex IV;
- (5) ‘component’ means a device that is intended to be part of a vehicle and that may be type-approved independently of that vehicle and that is subject to the requirements of this Regulation or any of the regulatory acts listed in Annex IV where the regulatory act makes express provisions for so doing;
- (6) ‘separate technical unit’ means a device intended to be part of a vehicle that may be type-approved separately, but only in relation to one or more specified types of vehicle and that is subject to the requirements of this Regulation or any of the regulatory acts listed in Annex IV where the regulatory act makes express provisions for so doing;

- (7) 'parts' means goods used for the assembly, repair and maintenance of a vehicle as well as spare parts;
- (8) 'equipment' means goods other than parts that can be added to or installed on a vehicle;
- (9) 'manufacturer' means a natural or legal person who is responsible for all aspects of the type-approval of a vehicle, system, component or separate technical unit, or the individual vehicle approval, or the authorisation process for parts and equipment, for ensuring conformity of production and for market surveillance matters regarding that vehicle, system, component, separate technical unit, part and equipment produced, irrespective of whether that person is or is not directly involved in all stages of the design and construction of that vehicle, system, component or separate technical unit concerned;
- (10) 'motor vehicle' means any power-driven vehicle designed and constructed to be moved by its own means, having at least four wheels, being complete, completed or incomplete, with a maximum design speed exceeding 25 km/h;
- (11) 'trailer' means any non-self-propelled vehicle on wheels designed and constructed to be towed by a motor vehicle, that can articulate at least around a horizontal axis perpendicular to the longitudinal median plane and a vertical axis parallel to the longitudinal median plane of the towing motor vehicle;
- (12) 'approval authority' means the authority or authorities of a Member State, notified to the Commission by that Member State, with competence for all aspects of the type-approval of a vehicle, system, component or separate technical unit, or of the individual vehicle approval, for the authorisation process for parts and equipment, for issuing and, if appropriate, withdrawing or refusing approval certificates, for acting as the contact point for the approval authorities of the other Member States, for designating the technical services, and for ensuring that the obligations regarding the conformity of production of the manufacturer are met;

- (13) ‘market surveillance authority’ means the national authority or authorities responsible for carrying out market surveillance on the territory of the Member State;
- (14) ‘national authority’ means an approval authority or any other authority involved in and responsible for market surveillance, border control or registration in a Member State in respect of vehicles, systems, components, separate technical units and parts or equipment;
- (15) ‘placing on the market’ means making available a vehicle, system, component, separate technical unit, part or equipment for the first time in the Union;
- (16) ‘registration’ means the administrative authorisation for the entry into service in road traffic of an approved vehicle, involving the identification of the vehicle and the issuing to it of a serial number, known as the registration number, whether on a permanent or temporary basis;
- (17) ‘entry into service’ means the first use, for its intended purpose, in the Union, of a vehicle, system, component, separate technical unit, part or equipment;
- (18) ‘economic operator’ means the manufacturer, the manufacturer’s representative, the importer or the distributor;
- (19) ‘whole-vehicle type-approval’ means the procedure whereby an approval authority certifies that an incomplete, complete or completed type of vehicle satisfies the relevant administrative provisions and technical requirements;
- (20) ‘multi-stage type-approval’ means the procedure whereby one or more approval authorities certify that depending on the state of completion, an incomplete or completed type of vehicle satisfies the relevant administrative provisions and technical requirements;

- (21) ‘incomplete vehicle’ means any vehicle that requires at least one further stage of completion in order to meet the relevant technical requirements of this Regulation;
- (22) ‘EU type-approval’ means the procedure whereby an approval authority certifies that a type of vehicle, system, component or separate technical unit satisfies the relevant administrative provisions and technical requirements of this Regulation;
- (23) ‘type-approval certificate’ means the document whereby the approval authority officially certifies that a type of vehicle, system, component or separate technical unit is type-approved;
- (24) ‘manufacturer’s representative’ means any natural or legal person established in the Union who is duly appointed by the manufacturer to represent the manufacturer before the approval authority or the market surveillance authority and to act on the manufacturer’s behalf in matters covered by this Regulation;
- (25) ‘importer’ means a natural or legal person established in the Union who places on the market a vehicle, system, component, separate technical unit, part or equipment that has been manufactured in a third country;
- (26) ‘national type-approval’ means the procedure whereby an approval authority certifies that a type of vehicle, system, component or separate technical unit satisfies the relevant administrative provisions and technical requirements laid down by the national law of a Member State, the validity of such approval being restricted to the territory of that Member State;
- (27) ‘certificate of conformity’ means the document issued by the manufacturer, which certifies that a produced vehicle conforms to the approved type of vehicle and complies with all regulatory acts at the time of its production;

- (28) ‘distributor’ means a dealer or any other natural or legal person in the supply chain, other than the manufacturer or the importer, who makes available on the market a vehicle, system, component, separate technical unit, part or equipment;
- (29) ‘making available on the market’ means any supply of a vehicle, system, component, separate technical unit, part or equipment for distribution or use on the market in the course of a commercial activity, whether in return for payment or free of charge;
- (30) ‘step-by-step type-approval’ means the procedure consisting of the step-by-step collection of the whole set of EU or UNECE type-approval certificates for the systems, components and separate technical units forming part of a vehicle, and which leads, at the final stage, to the whole-vehicle type-approval;
- (31) ‘single-step type-approval’ means the procedure whereby an approval authority certifies that a type of vehicle, system, component or separate technical unit as a whole satisfies the relevant administrative provisions and technical requirements by means of a single operation;
- (32) ‘mixed type-approval’ means a step-by-step type-approval for which one or more system type-approvals have been obtained during the final stage of the whole-vehicle type-approval, without the need to issue the EU type-approval certificates for those systems;
- (33) ‘completed vehicle’ means a vehicle resulting from the multi-stage type-approval that meets the relevant technical requirements of this Regulation;
- (34) ‘complete vehicle’ means a vehicle that does not need to be completed in order to meet the relevant technical requirements of this Regulation;

- (35) ‘type of vehicle’ means a particular group of vehicles that shares at least the essential criteria specified in Part B of Annex II, and that may contain variants and versions as referred thereto;
- (36) ‘technical service’ means an organisation or body designated by the approval authority as a testing laboratory to carry out tests, or as a conformity assessment body to carry out the initial assessment and other tests or inspections;
- (37) ‘base vehicle’ means any vehicle that is used at the initial stage of a multi-stage type-approval;
- (38) ‘system type-approval’ means the procedure whereby an approval authority certifies that a type of system satisfies the relevant administrative provisions and technical requirements;
- (39) ‘separate technical unit type-approval’ means the procedure whereby an approval authority certifies that a type of separate technical unit satisfies the relevant administrative provisions and technical requirements in relation to one or more specified types of vehicles;
- (40) ‘component type-approval’ means the procedure whereby an approval authority certifies that a type of component independently of a vehicle satisfies the relevant administrative provisions and technical requirements;
- (41) ‘virtual testing method’ means computer simulations, including calculations, to demonstrate that a vehicle, a system, a component or a separate technical unit fulfils the technical requirements of a regulatory act listed in Annex IV without requiring the use of a physical vehicle, system, component or separate technical unit;
- (42) ‘individual vehicle approval’ means the procedure whereby an approval authority certifies that a particular vehicle, whether unique or not, satisfies the relevant administrative provisions and technical requirements for EU individual vehicle approval or national individual vehicle approval;

- (43) ‘end-of-series vehicle’ means a vehicle that is part of a stock and that, due to the entry into force of new technical requirements against which it has not been type-approved, cannot or can no longer be made available on the market, registered or entered into service;
- (44) ‘alternative requirements’ means administrative provisions and technical requirements that aim to ensure a level of functional safety, environmental protection and occupational safety that to the greatest extent practicable is equivalent to the level provided for by one or more of the regulatory acts listed in Annex IV;
- (45) ‘spare parts’ means goods that are to be installed in or on a vehicle to replace original parts of that vehicle, including goods that are necessary for the use of a vehicle, with the exception of fuel;
- (46) ‘vehicle repair and maintenance information’ means all information, including all subsequent amendments and supplements to that information, required for diagnosing, servicing, inspecting, preparing for road worthiness testing, repairing, re-programming, or re-initialising or the remote diagnostic support of a vehicle as well as for the fitting on vehicles of parts and equipment, and that is provided by the manufacturer to his authorised partners, dealers and repairers or used by the manufacturer for the repair and maintenance purposes.
- (47) ‘independent operator’ means a natural or legal person, other than an authorised dealer or repairer, who is directly or indirectly involved in the repair and maintenance of vehicles, including repairers, manufacturers or distributors of repair equipment, tools or spare parts, publishers of technical information, automobile clubs, roadside assistance operators, operators offering inspection and testing services, operators offering training for installers, manufacturers and repairers of equipment for alternative-fuel vehicles; it also means authorised repairers, dealers or distributors within the distribution system of a given vehicle manufacturer to the extent that they provide repair and maintenance services for vehicles in respect of which they are not members of the vehicle manufacturer’s distribution system;

- (48) ‘authorised repairer’ means a natural or legal person providing repair and maintenance services for vehicles operating within the manufacturer’s distribution system;
- (49) ‘independent repairer’ means a natural or legal person providing repair and maintenance services for vehicles not operating within the manufacturer’s distribution system;
- (50) ‘vehicle on-board diagnostic (OBD) information’ means the information relating to a system on board of a vehicle or that is connected to an engine and that has the capability of detecting a malfunction, and, where applicable, of indicating its occurrence by means of an alert system, of identifying the likely area of malfunction by means of information stored in a computer memory, and of communicating that information off-board;
- (50a) ‘alternative-fuel vehicle’ means a vehicle designed to be capable of running on at least one type of fuel that is either gaseous at atmospheric temperature and pressure, or substantially non-mineral oil derived;
- (51) ‘vehicle produced in small series’ means a type of vehicle of which the number of units that is made available on the market, registered or entered into service does not exceed the quantitative annual limits laid down in Annex XII;
- (52) ‘special purpose vehicle’ (SPV) means a vehicle of category M, N or O having specific technical features to perform a function that requires special arrangements or equipment;
- (53) ‘Semi-trailer’ means a towed vehicle, in which the axle(s) is (are) positioned behind the centre of gravity of the vehicle (when uniformly loaded), and which is equipped with a connecting device permitting horizontal and vertical forces to be transmitted to the towing vehicle.
- (54) ‘national accreditation body’ means the sole body in a Member State that performs accreditation with authority derived from the State, as laid down in Article 2(11) of Regulation (EC) No 765/2008;

- (55) ‘on-site assessment’ means a verification in the premises of the technical service or of one of its subcontractors or subsidiaries;
- (56) ‘surveillance on-site assessment’ means a periodic routine on-site assessment which is neither the on-site assessment undertaken for the initial designation, nor the on-site assessment undertaken for the renewal of the designation;
- (56a) ‘date of manufacture of the vehicle’ means the date when the manufacture of a vehicle has been finalised in accordance with the approval obtained by that manufacturer.

Article 4
Vehicle categories

1. For the purposes of this Regulation, the following vehicle categories shall apply:
 - (a) Category M comprises motor vehicles designed and constructed primarily for the carriage of persons and their luggage, namely:
 - (i) Category M₁: motor vehicles comprising not more than eight seating positions in addition to the driver’s seating position and without space for standing passengers. The number of seating positions may be restricted to the driver’s seating position;
 - (ii) Category M₂: motor vehicles comprising more than eight seating positions in addition to the driver’s seating position and having a maximum mass not exceeding 5 tonnes. These motor vehicles may have space for standing passengers;
 - (iii) Category M₃: motor vehicles comprising more than eight seating positions in addition to the driver’s seating position and having a maximum mass exceeding 5 tonnes. These motor vehicles may have space for standing passengers.
 - (b) Category N comprises motor vehicles designed and constructed primarily for the carriage of goods, namely:
 - (i) Category N₁: motor vehicles having a maximum mass not exceeding 3,5 tonnes;

- (ii) Category N₂: motor vehicles having a maximum mass exceeding 3,5 tonnes but not exceeding 12 tonnes;
 - (iii) Category N₃: motor vehicles having a maximum mass exceeding 12 tonnes.
- (c) Category O comprises trailers, namely:
- (i) Category O₁: trailers having a maximum mass not exceeding 0,75 tonnes;
 - (ii) Category O₂: trailers having a maximum mass exceeding 0,75 tonnes but not exceeding 3,5 tonnes;
 - (iii) Category O₃: trailers having a maximum mass exceeding 3,5 tonnes but not exceeding 10 tonnes;
 - (iv) Category O₄: trailers having a maximum mass exceeding 10 tonnes.

2. The criteria for the categorisation of vehicles, types of vehicle, variants and versions are specified in Annex II.

The Commission shall be empowered to adopt delegated acts in accordance with Article 88 to amend Annex II concerning the types of vehicle and types of bodywork in order to adapt it to technical progress.

CHAPTER II GENERAL OBLIGATIONS

Article 5 *Technical requirements*

1. Vehicles, systems, components and separate technical units shall comply with the requirements of the regulatory acts listed in Annex IV.
 - 1a. Vehicles, systems, components and separate technical units are deemed not to comply with the requirements of this Regulation, in particular in the following cases:
 - (a) if they deviate from the particulars in the type-approval certificates, their attachments or descriptive particulars in the test reports more than provided by the regulatory act in question,
 - (b) where performance criteria or limit values provided in the regulatory act in question for series production are not fulfilled under all conditions provided by the regulatory act in question,
 - (c) if any information given by the manufacturer in the information document is not reproducible under all conditions provided by the regulatory act in question by approval authorities, market surveillance authorities and the Commission.

Only checks, tests, inspections and assessments conducted by or carried out on behalf of the approval authorities, market surveillance authorities or the Commission shall be taken into account for the assessment of compliance referred to in this paragraph.

2. The Commission shall be empowered to adopt delegated acts in accordance with Article 88 to amend Annex IV to take account of technological and regulatory developments by introducing and updating references to regulatory acts containing the requirements with which vehicles, systems, components and separate technical units have to comply.

Article 6
Obligations of Member States

1. Member States shall establish or appoint the approval authorities and the market surveillance authorities. Member States shall notify the Commission of the establishment and appointment of such authorities.

That notification shall include the name of those authorities, their address, including their electronic address, and their competences. The Commission shall publish on its website a list and details of the approval authorities and the market surveillance authorities.

Member States shall ensure that approval authorities and market surveillance authorities adhere to a strict separation of roles and responsibilities and function independently from each other. The authorities may be within the same organisation provided that their activities are managed autonomously as part of separate structure.

- 1a. A Member State where more than one approval authority is responsible for vehicle approval including individual vehicle approval, shall designate a unique type approval authority responsible for the exchange of information with the approval authorities of the other Member States, for the purpose of Article 10 and for the obligations set out in Chapter XV of this Regulation.
- 1b. A Member State where more than one market surveillance authority is responsible for market surveillance, shall designate a unique market surveillance authority responsible for the exchange of information with the market surveillance authorities of the other Member States for the purpose of Article 10.
2. Member States shall permit the placing on the market, registration or entry into service of only those vehicles, systems, components and separate technical units that comply with the requirements set out in this Regulation.

3. Member States shall not prohibit, restrict or impede the placing on the market, registration or entry into service of vehicles, systems, components or separate technical units that comply with the requirements set out in this Regulation, except in the cases provided in Chapter XI.
By way of derogation from that rule, Member States are not obliged to allow the circulation on the road, the placing on the market, registration or entry into service of vehicles that are type-approved in accordance with this Regulation, but exceed the harmonised dimensions, weights and axle loads laid down in Annex I to Council Directive 96/53/EC¹⁶.
4. Member States shall organise and carry out market surveillance and controls of vehicles, systems, components or separate technical units entering the market, in accordance with this Regulation and Chapter III of Regulation (EC) No 765/2008.
5. Member States shall take the necessary measures to ensure that market surveillance authorities may, where they consider it necessary and justified, be entitled to enter the premises of economic operators on their territory and take the necessary samples of vehicles, systems, components and separate technical units for the purposes of compliance testing.
6. The Member States shall periodically review and assess the functioning of their type-approval activities. Such reviews and assessments shall be carried out at least every four years and the results thereof shall be communicated to the Commission and the Forum for Exchange of Information on Enforcement.

The Member States shall report to the Commission and the Forum for Exchange of Information on Enforcement on how they address any recommendations issued by the Forum.

The Member State concerned shall make accessible to the public a summary of the results of periodic reviews and assessments.

¹⁶ Council Directive 96/53/EC of 25 July 1996 laying down for certain road vehicles circulating within the Community the maximum authorized dimensions in national and international traffic and the maximum authorized weights in international traffic (OJ L 235 17.9.1996, p. 59).

7. The Member States shall periodically review and assess the functioning of their market surveillance activities. Such reviews and assessments shall be carried out at least every four years and the results thereof shall be communicated to the Commission and to the Forum for Exchange of Information on Enforcement.

The Member States shall report to the Commission and the Forum for Exchange of Information on Enforcement on how they address any recommendations issued by the Forum.

The Member State concerned shall make accessible to the public a summary of the results of periodic reviews and assessments.

8. The Commission may adopt implementing acts to lay down the common criteria for the format of reporting on the review and assessment referred to in paragraphs 6 and 7 of this Article. Those implementing acts shall be adopted in accordance with the examination procedure referred to in Article 87(2).

Article 7
Obligations of approval authorities

1. Approval authorities shall only approve such vehicles, systems, components or separate technical units that comply with the requirements of this Regulation.
2. Approval authorities shall carry out their duties independently and impartially. They shall observe confidentiality in order to protect commercial secrets, subject to the obligation of information laid down in Article 9(3) or other applicable disclosure requirements set out in Union law in order to protect the interests of users in the Union.
3. [...]

Approval authorities shall cooperate efficiently and effectively and share information relevant to their role and functions.

- 3a. For the purpose of enabling market surveillance authorities to carry out testing, approval authorities shall make available to market surveillance authorities the necessary information related to the type-approval of the vehicle, systems, components and separate technical units subject to compliance verification testing. The information shall include at least the information included in the type-approval certificate and its attachments referred to in Article 26(1), and shall be provided without undue delay.
4. Where an approval authority is informed in accordance with Chapter XI, it shall take all necessary measures to review the approval granted and, where appropriate, correct or withdraw the approval depending on the reasons and the seriousness of the deviations demonstrated.
5. [...]

Article 8
Obligations of market surveillance authorities

1. Market surveillance authorities shall carry out regular checks to verify compliance of vehicles, systems, components and separate technical units with the relevant requirements. Those checks shall be performed on an adequate scale by means of documentary checks and, where appropriate, laboratory and on-road tests on the basis of statistically relevant samples. When carrying out those checks market surveillance authorities shall take account of:
 - established principles of risk assessment,
 - substantiated complaints, and
 - any other relevant information, including the information exchanged in the Forum and testing results published by recognised third party testing organisations that meet the requirements set out in the implementing acts adopted in accordance with Article 11(7b).

- 1a. Without prejudice to paragraph 1, the market surveillance authorities of each Member State shall carry out at least a minimum number of tests per year on vehicles. This minimum number of tests per Member State shall be 1 in every 40 000 new motor vehicles registered in that Member State in the preceding year, but not less than five tests.
- Each test shall be performed to verify compliance with the applicable regulatory acts listed in Annex IV.
- 1b. Market surveillance authorities carrying out more than five tests per year shall carry out at least 20% of the minimum number of tests on emission-related tests comparable to type approval tests covering all applicable emissions-related requirements to the tested type as laid down in the regulatory acts listed in Annex IV.
- 1c. The market surveillance authority of a Member State may agree with the market surveillance authority of another Member State that the latter carries out tests required under paragraphs 1a and 1b.
- 1d. The market surveillance authority of a Member State may agree with the Commission to carry out tests required under paragraph 1b at the expense of that Member State. Any tests carried out under this paragraph shall be considered to contribute towards the minimum number of tests required under paragraph 1a.
- 1e. The Member States shall annually prepare a comprehensive overview of their planned market surveillance checks and submit it to the Forum no later than 1 March.
- 1f. Each Member State shall draw up every two years a report of its findings following any compliance verification testing it has carried out in the previous two years. This report shall be submitted to the Forum no later than 30 September of the year following the end of the two-year period concerned.

2. Market surveillance authorities shall require economic operators to make available to the authorities the documentation, information and any other technical specifications, including access to software and algorithms, as the authorities consider necessary for the purpose of carrying out market surveillance activities.
3. For type-approved vehicles, systems, components and separate technical units, market surveillance authorities shall take due account of certificates of conformity, type-approval marks or type-approval certificates presented by economic operators.
4. Market surveillance authorities shall take appropriate measures to alert users within their territories within an adequate timeframe of hazards they or the Commission have identified relating to any vehicle, system, component and separate technical unit so as to prevent or reduce the risk of injury or other damage. This information shall also be made available on the website of the market surveillance authority.

Market surveillance authorities shall cooperate with economic operators regarding actions which could prevent or reduce risks caused by vehicles, systems, components and separate technical units made available by those operators.

5. Where the market surveillance authorities of one Member State decide to withdraw a vehicle, system, component and separate technical unit from the market in accordance with Chapter XI, they shall inform the economic operator concerned and the relevant approval authority.
6. Market surveillance authorities shall carry out their duties independently and impartially. They shall observe confidentiality in order to protect commercial secrets, subject to the obligation of information laid down in Article 9(3) or other applicable disclosure requirements set out in Union law in order to protect the interests of users in the European Union.
7. [...]
8. The market surveillance authorities of different Member States shall coordinate their market surveillance activities, cooperate with each other and share with each other and with the Forum the results thereof. Where appropriate, the market surveillance authorities shall agree on work-sharing and specialisation.
9. Where more than one authority in a Member State is responsible for market surveillance and external border controls, those authorities shall cooperate efficiently and effectively and share information relevant to their role and functions.
10. The Commission may adopt implementing acts to lay down common criteria for establishing the adequate scale of the compliance verification checks referred to in paragraph 1 and common criteria for the format of reporting referred to in paragraphs 1e and 1f. Those implementing acts shall be adopted in accordance with the examination procedure referred to in Article 87(2).

Article 9
Compliance verification by the Commission

1. The Commission shall organise and carry out, at its own expense, tests and inspections of vehicles, systems, components and separate technical units, with a view to verifying that those vehicles, systems, components and separate technical units comply with the relevant requirements.

The tests and inspections shall be performed by means of, inter alia, laboratory tests and on-road tests, on the basis of statistically relevant samples, and shall be supplemented by documentary checks.

When doing so, the Commission shall take account of established principles of risk assessment, substantiated complaints and other relevant information, including the information exchanged in the Forum in accordance with Article 10, testing results published by recognised third parties in accordance with the implementing acts referred to in Article 11(7b), new technologies on the market and reports from on-road remote sensing.

The Commission may rely on technical services to perform the technical tasks, such as tests or inspections. In that case, the technical service shall be acting on behalf of the Commission. Where the Commission relies on technical services for the purposes of this Article, the Commission shall ensure that a different technical service is used from the technical service that performed the original type approval test.

Those tests and inspections may take place on new vehicles supplied by manufacturers or the economic operator as provided for in paragraph 2.

Those tests and inspections may also take place on registered vehicles in agreement with the holder of the vehicle registration certificate.

2. Manufacturers holding type-approvals or other economic operators shall, upon request, supply to the Commission against fair compensation, a statistically relevant number of production vehicles, systems, components and separate technical units selected by the Commission that are representative for the vehicles, systems, components and separate technical units available for placing on the market under that type-approval. Those vehicles, systems, components and separate technical units shall be supplied for testing at the time and place and for the period the Commission may require.

2a. Before the Commission carries out its compliance tests and inspections, notice shall be given to the Member State that issued the type approval and the Member State where the vehicle, system, component or separate technical unit was made available on the market.

The Member States shall cooperate with the Commission when the Commission carries out these tests, checks and inspections.

3. For the purpose of enabling the Commission to carry out the testing referred to in paragraphs 1 and 2, Member States shall make available to the Commission the necessary information related to the type-approval of the vehicle, systems, components and separate technical units subject to compliance verification testing. The information shall include at least the information included in the type-approval certificate and its attachments referred to Article 26(1), and shall be provided without undue delay.

[...]

4. Vehicle manufacturers shall make available to the Commission free of charge and without undue delay data which is needed for the purpose of compliance verification and which is not available in the type-approval certificate and its attachments.

That data shall include all parameters and settings that are necessary to accurately replicate the test conditions that were applied at the time of the type-approval testing. The Commission shall adopt implementing acts in order to define the data to be made available, subject to the protection of commercial secrets and the preservation of personal data pursuant to Union and national legislation. Those implementing acts shall be adopted in accordance with the examination procedure referred to in Article 87(2).

5. Where the Commission establishes that the vehicles, components and separate technical units do not comply with the type-approval requirements laid down in this Regulation, that the vehicles, components or separate technical unit do not comply with the characteristics according to the type-approval or that the type approval has been granted on the basis of incorrect data, it shall initiate the procedure provided for in Articles 50 and 54.

Where those tests and inspections put into question the correctness of the type approval itself, the Commission shall immediately inform the approval authority or authorities concerned as well as the Forum for Exchange of Information on Enforcement.

The Commission shall inform the relevant type-approval and market surveillance authorities in order to take appropriate measures to alert users within the Union, within an adequate timeframe, of any non-compliance that it has identified relating to any vehicle, system, component and separate technical unit so as to prevent or reduce the risk of injury or other damage.

The Commission shall make publicly available a report of its findings following any compliance verification testing it has carried out and shall forward its findings to the Member States and to the Forum for Enforcement. The report shall contain details of the vehicles, systems, components or separate technical units that are assessed and the identity of the corresponding manufacturer, and a short description of the findings, including the nature of the non-compliance, if any.

Article 9a
Assessments by the Commission

1. The Commission shall organise and carry out assessments of the procedures put in place by authorities that have granted EU type approvals within the five years preceding the assessment, in particular the procedures for granting type approvals, for carrying out conformity of production and for designating and monitoring of technical services. The assessment shall include an evaluation by way of random sample of the compliance of issued type-approvals with Article 24(2)(c) within the five years preceding the assessment.
2. The assessments shall aim at assisting the authorities granting EU type approvals in ensuring the uniform application of the provisions of this Regulation and in sharing best practices.
3. The assessments shall be carried out in compliance with the national law of the Member State concerned, with due regard for the rights of the authorities and in compliance with the principle of proportionality. The Commission shall carry out its duties independently and impartially and shall observe confidentiality in order to protect commercial secrets in accordance with the applicable law. The Commission shall bear the cost arising from the assessments.
4. The authorities concerned shall facilitate the assessment by cooperating with the Commission giving it necessary assistance and providing it with the necessary documentation.
5. The Commission shall ensure that the personnel participating in the assessment is sufficiently qualified and adequately instructed. The Commission shall inform the Member States and the authorities concerned in good time before the assessment of the date on which it is to begin and of the identity of the personnel carrying out the assessment. In principle, the duration of the on-site assessment at the authority concerned shall not exceed two days, and shall in any case not exceed three days.

6. Each authority that has granted type approval during a five year period shall be assessed by the Commission once during that period.

By way of derogation from the first subparagraph, the assessment of an authority may be less frequent, if the Commission considers that the first assessment of that authority demonstrates that the procedures put in place ensure the effective applying of this Regulation, taking into account the scope and range of EU type approvals granted.

7. The Commission shall communicate the outcome of the assessment, including any recommendations, to the Forum and make publicly available a summary of the outcome. The Forum shall examine the outcome of the assessment.
8. The Member States shall report to the Commission and the Forum on how they address any recommendations included in the outcome of the assessment.
9. Taking duly into account the considerations of the Forum, the Commission shall adopt implementing acts to lay down common criteria for setting out the scope, the methodology used for the assessment, the composition of the assessment team, the plan for the assessments covering a period of at least 5 years and the specific terms for reducing the frequency of assessments. Those implementing acts shall be adopted in accordance with the examination procedure referred to in Article 87(2).

Article 10
Forum for Exchange of Information on Enforcement

1. The Commission shall establish, chair and manage a Forum for Exchange of Information on Enforcement ('the Forum').

This Forum shall be composed of representatives appointed by each Member State representing the approval authorities and the market surveillance authorities.

Whenever appropriate, technical services, recognised third party testing organisations that meet the requirements set out in the implementing acts adopted in accordance with Article 11(7b), representatives of the European Parliament, industry or other relevant economic operators, as well as stakeholders involved in safety and environment matters may be invited as observers to the Forum in accordance with the rules of procedures adopted in accordance with paragraph 3.

2. [...]

The advisory tasks of the Forum shall have as objective the promotion of good practices in order to facilitate the uniform interpretation and implementation of this Regulation, the exchange of information on enforcement problems, cooperation, in particular regarding the assessment, designation and monitoring of technical services, development of working methods and tools, development of an electronic information exchange procedure, evaluation of harmonised enforcement projects, and penalties.

- 2a. The Forum shall consider:

- (-a) matters related to uniform interpretation of the requirements set out in this Regulation and in the regulatory acts listed in Annex IV during implementation of these requirements;
- (a) the results of the activities of type-approval and market surveillance carried out by Member States in accordance with Articles 6(6) and 6(7);
- (aa) test reports of possible non-compliance presented by third parties that meet the requirements set out in the implementing acts adopted in accordance with Article 11(7b);

- (b) the reports submitted under Article 71(7) by Member States on their procedures for the assessment, designation and notification of technical services and for the monitoring of technical services;
 - (c) matters of general relevance with regard to the implementation of the requirements set out in this Regulation in relation with the assessment, designation and monitoring of technical services in accordance with Article 82(4);
 - (d) infringements by economic operators;
 - (da) implementation of the corrective or restrictive measures set out in Chapter XI;
 - (e) the planning, coordination and results of market surveillance activities;
 - (f) the results of tests and inspections carried out by the Commission in accordance with Article 9;
 - (fa) the assessments carried out by the Commission in accordance with Article 9a;
 - (g) the results of the Conformity of Production activities carried out by Member States in accordance with Article 29;
 - (h) matters regarding access to vehicle OBD and vehicle repair and maintenance information set out in Chapter XIV and, in particular, matters regarding the implementation of the procedures established in Article 69;
- 2b. On the basis of the information provided by Member States in accordance with Article 8(1f), the Commission shall make publicly available a summary report on market surveillance activities on a two year basis.
- 2c. Each year the Commission shall present the summary of the activities of the Forum to the European Parliament.
- 2d. As part of the advisory task and taking into account the outcome of the considerations in accordance with paragraph 2a, the Forum may express an opinion or issue a recommendation.

The Forum shall endeavour to reach consensus. If such consensus cannot be reached, the Forum shall express its opinion or issue recommendations by simple majority of Member States. Each Member State shall have one vote. Member States with diverging positions may request that their positions and the grounds on which they are based are recorded in the Forum's opinion or recommendations.

- 2e. Where the Commission adopts implementing acts, the Commission shall take duly into account the opinions expressed by the Forum pursuant to paragraph 2d.
3. The Forum shall establish its rules of procedure.

[...]

Article 10a
On-line data exchange

1. The Commission and Member states shall use common secure electronic exchange system as set out by the implementing act adopted in accordance with Article 25(5) related to type-approval certificate, together with the attachments, including the test reports as well as amendments, refusal or withdrawal of any EU type-approval.

The Commission and Member states shall use the EU Rapid Warning System (RAPEX) and the Information and Communication System on Market Surveillance (ICSMS) for market surveillance, recalls and other relevant activities between market surveillance authorities, Member States and the Commission.

2. From [date referred to in Article 35(8)], Member States shall make accessible to the public by vehicle identification number the certificate of conformity of each vehicle as structured data in electronic format in the common secure electronic exchange system in accordance with Article 35.

From [date referred to in Article 35(8)], Member States shall make accessible to the public the information contained in the certificate of conformity as structured data in electronic format, excluding vehicle identification numbers, in the common secure electronic exchange system in accordance with Article 35.

The Commission shall adopt implementing acts establishing the format of and the criteria of access to the publicly accessible information referred to in the first and second subparagraphs.

Those implementing acts shall be adopted in accordance with the examination procedure referred to in Article 87(2).

3. The Commission shall take all necessary measures to establish an interface between the electronic exchange system and the EU Rapid Warning System (RAPEX) and the Information and Communication System on Market Surveillance (ICSMS) in order to facilitate market surveillance activities and ensure coordination, consistency and accuracy of the information provided to consumers and third parties.

4. Member States shall use common secure electronic exchange system as set out by Article 25 in order to make accessible to the public from [2 years after the date of application of this Regulation] a list of the EU type-approvals for vehicles, systems, components or separate technical units they have issued, amended, refused to grant or withdrawn as well as the technical services which have performed the tests for the respective EU type- approvals.

The Commission shall adopt implementing acts establishing the format and the criteria for access of the publicly accessible information referred to in the first subparagraph.

Those implementing acts shall be adopted in accordance with the examination procedure referred to in Article 87(2).

5. The Commission shall develop a tool to make publicly accessible test results and complaints about the performance of vehicles, systems, components and technical units from recognised third party testing organisations that meet the requirements set out in the implementing acts adopted in accordance with Article 11(7b).

Article 11
General obligations of manufacturers

1. The manufacturer shall ensure that the vehicles, systems, components and separate technical units that he has manufactured and that are placed on the market have been manufactured and approved in accordance with the requirements set out in this Regulation, in particular Article 5.
2. The manufacturer shall be responsible to the approval authority for all aspects of the approval procedure and for ensuring conformity of production.

In the case of multi-stage type-approval, the manufacturer shall also be responsible for the approval and conformity of production of the systems, components or separate technical units that he has added at the stage of vehicle completion. Any manufacturer who modifies components, systems or separate technical units already approved at earlier stages shall be responsible for the approval and conformity of production of the modified components, systems or separate technical units. The manufacturer of the previous stage shall provide information to the manufacturer of the subsequent stage regarding any change that may affect component type-approval, system type-approval or separate technical unit type-approval or the whole-vehicle type-approval. Such information shall be provided as soon as the new extension to the whole-vehicle type-approval has been issued and at the latest on the starting date of production of the incomplete vehicle.

3. The manufacturer who modifies an incomplete vehicle in such a manner that it qualifies as a different category of vehicle, with the consequence that the requirements already assessed in a previous stage of type-approval have changed, shall also be responsible for compliance with the requirements applicable to the category of vehicles for which the modified vehicle qualifies.
4. For the purposes of EU type-approval of vehicles, systems, components or separate technical units, a manufacturer established outside the Union shall appoint a single representative established within the Union to represent the manufacturer before the approval authority. That manufacturer shall also appoint a single representative established within the Union for the purposes of market surveillance, who may be the same representative appointed for the purposes of EU type-approval.

- 4a. Manufacturers shall ensure that their vehicles, systems, components or separate technical units are not designed to incorporate strategies or other means that alter the performance exhibited during test procedures in such a way that they do not comply with this Regulation under conditions that can reasonably be expected in normal operation.
5. [...]
6. The manufacturer shall establish procedures to ensure that series production of vehicles, systems, components and separate technical units remains in conformity with the approved type.
- 6a. The manufacturer shall examine any complaints he receives relating to risks, suspected incidents or non-compliance issues with the vehicles, systems, components, separate technical units, parts and equipment that he has placed on the market.
- He shall keep a record of those complaints, including for each one a description of the issue and the details needed to precisely identify the affected type, and in case of substantiated complaints, keep his distributors and importers informed thereof.
7. In addition to the statutory plate fixed to their vehicles and type-approval marks fixed to their components or separate technical units in accordance with Article 36, the manufacturer shall indicate his name, registered trade name or registered trade mark and his contact address in the Union on his vehicles, components or separate technical units made available on the market or, where that is not possible, on the packaging or in a document accompanying the component or separate technical unit.
- 7a. Manufacturers shall ensure that, while a vehicle, system, component or separate technical unit is under their responsibility, storage or transport conditions do not jeopardise its compliance with the requirements set out in this Regulation.

- 7b. Without prejudice to Article 9(4) and subject to the protection of commercial secrets and the preservation of personal data pursuant to Union and national legislation, vehicle manufacturers shall make available data, which is needed for testing for possible non-compliance by third parties, include all parameters and settings that are necessary to accurately replicate the test conditions that were applied at the time of the type-approval testing. The Commission shall adopt implementing acts in order to define the data to be made available free of charge as well as the requirements to be met by third parties concerning demonstration of their legitimate interest in the fields of public safety or environmental protection and recourse to adequate testing facilities. Those implementing acts shall be adopted in accordance with the examination procedure referred to in Article 87(2).

Article 12

Obligations of manufacturers concerning their vehicles, systems, components, separate technical units or parts and equipment that are not in conformity or that present a serious risk

1. Where a vehicle, system, component, separate technical unit, or part or equipment that has been placed on the market or entered into service is not in conformity with this Regulation or that the type approval has been granted on the basis of incorrect data, the manufacturer shall immediately take the appropriate measures necessary to bring that vehicle, system, component, separate technical unit, part or equipment into conformity, to withdraw it from the market or to recall it, as appropriate.

The manufacturer shall immediately inform the approval authority that has granted the approval in detail of the non-conformity and of any measures taken.

2. Where the vehicle, system, component, separate technical unit, part or equipment presents a serious risk, the manufacturer shall immediately provide detailed information on the risk and on any measures taken to the approval and market surveillance authorities of the Member States.

3. The manufacturer shall keep the type-approval certificate and its attachments for a period of ten years after the end of validity of the vehicle EU type-approval and for a period of five years after the end of validity of the EU type-approval of a system, component or separate technical unit.

The vehicle manufacturer shall keep at the disposal of the approval authorities for a period of ten years from the production date of the vehicle a copy of the certificates of conformity referred to in Article 34.

4. The manufacturer shall, upon a reasoned request from a national authority or the Commission, provide that authority or the Commission, with a copy of the EU type-approval certificate or the authorisation referred to in Article 55(1) demonstrating conformity of the vehicle, system, component or separate technical unit, part or equipment in a language that can be easily understood by the national authority or the Commission.

The manufacturer shall, following a reasoned request from a national authority, cooperate with that authority on any action taken in accordance with Article 20 of Regulation (EC) No 765/2008 to eliminate the risks posed by the vehicle, system, component, separate technical unit, part or equipment that he has made available on the market.

Article 13

Obligations of manufacturer's representatives

1. The manufacturer's representative shall perform the tasks specified in the mandate received from the manufacturer. That mandate shall at least provide for the representative to :
 - (a) have access to the type-approval certificate and its attachments and the certificate of conformity in one of the official Union languages. Such documentation shall be made available to the approval authorities and the market surveillance authorities for a period of ten years after the end of validity of the-vehicle EU type-approval and for a period of five years after the end of validity of the EU type-approval of a system, component or separate technical unit;

- (b) provide an approval authority, following a reasoned request from that authority with all the information, documentation and any other technical specifications, including access to software and algorithms necessary to demonstrate the conformity of production of a vehicle, system, component or separate technical unit;
 - (c) cooperate with the approval or market surveillance authorities, at their request, on any action taken to eliminate the serious risk posed by vehicles, systems, components, separate technical units, parts or equipment covered by that mandate;
 - (d) immediately inform the manufacturer about complaints and reports relating to risks, suspected incidents, non-compliance issues with vehicles, systems, components, separate technical units, parts or equipment covered by that mandate;
 - (e) be able to terminate that mandate without penalty if the manufacturer acts contrary to his obligations under this Regulation.
2. A manufacturer's representative who terminates the mandate on the grounds referred to in point (e) of paragraph 1 shall immediately inform the type approval authority that granted the approval and the Commission.
3. The information to be provided shall include at least:
- (a) the date of termination of the mandate;
 - (b) the date until which the outgoing manufacturer's representative may be indicated in the information supplied by the manufacturer, including any promotional material;
 - (c) the transfer of documents, including confidentiality aspects and property rights;
 - (d) the obligation of the outgoing manufacturer's representative after the end of the mandate to forward to the manufacturer or incoming manufacturer's representative any complaints or reports about risks and suspected incidents related to a vehicle, system, component, separate technical unit, part or equipment for which he had been designated as manufacturer's representative.

Article 14
Obligations of importers

1. The importer shall place on the market only vehicles, systems, components or separate technical units that comply with this Regulation.
2. Before placing on the market a type-approved vehicle, system, component or separate technical unit, the importer shall verify that it is covered by a valid type-approval certificate and that the system, component or separate technical unit bears the required type-approval mark and complies with Article 11(7).

In the case of a vehicle, the importer shall ensure that the vehicle is accompanied by the required certificate of conformity.

3. Where a vehicle, system, component or separate technical unit is not in conformity with the requirements of this Regulation, and in particular that it does not correspond to its type-approval, the importer shall not place on the market, allow to enter into service or register the vehicle, system, component or separate technical unit, until it has been brought into conformity.
- 3a. Where the vehicle, system, component, separate technical unit, part or equipment presents a serious risk, the importer shall inform the manufacturer and the market surveillance authorities thereof. For type-approved vehicles, systems, components and separate technical units, he shall also inform the approval authority that has granted the type-approval.
4. The importer shall indicate his name, registered trade name or registered trade mark and his contact address on the vehicle, system, component, separate technical unit, part or equipment, or, where this is not possible, on its packaging or in a document accompanying the system, component, separate technical unit, part or equipment.
5. The importer shall ensure that the vehicle, system, component or separate technical unit is accompanied by the instructions and information required by Article 63 in the official language or languages of the Member States concerned.

6. The importer shall, to protect the health and safety of consumers, keep a record of complaints and recalls of vehicles, systems, components, separate technical units, parts or equipment that he has placed on the market and keep his distributors informed of such complaints and recalls.
7. The importer shall immediately inform the relevant manufacturer of any complaints he receives relating to risks, suspected incidents or non-compliance issues with marketed vehicles, systems, components, separate technical units, parts or equipment.
- 7a. Importers shall ensure that, while a vehicle, system, component or separate technical unit is under their responsibility, storage or transport conditions do not jeopardise its compliance with the requirements set out in this Regulation.

Article 15

Obligations of importers concerning their vehicles, systems, components or separate technical units that are not in conformity or concerning their vehicles, systems, components, separate technical units, parts or equipment that present a serious risk

1. Where a vehicle, system, component or separate technical unit that has been placed on the market by the importer is not in conformity with this Regulation, the importer shall immediately take the appropriate measures necessary to bring that vehicle, system, component or separate technical unit into conformity under the manufacturer's control, to withdraw it from the market, or to recall it, as appropriate. The importer shall also inform the manufacturer and the approval authority that has granted the type-approval.
2. Where a vehicle, system, component, separate technical unit, part or equipment that has been placed on the market presents a serious risk, the importer shall immediately provide detailed information on the serious risk to the manufacturer and the approval and market surveillance authorities of the Member States.

The importer shall also inform the approval and market surveillance authorities of any action taken and give details, in particular of the serious risk and of corrective measures taken by the manufacturer.

3. The importer shall, for a period of ten years after the end of validity of the vehicle EU type-approval and for a period of five years after the end of validity of the EU type-approval of a system, component or separate technical unit, keep a copy of the type-approval certificate and its attachments, and ensure that these can be made available to the approval and market surveillance authorities, upon request.
4. The importer shall, upon a reasoned request from a national authority, provide that authority with all the information and documentation necessary to demonstrate the conformity of a vehicle, system, component or separate technical unit in a language that can be easily understood by that authority. The importer shall, following a reasoned request from a national authority, cooperate with that authority on any action taken in accordance with Article 20 of Regulation (EC) No 765/2008 to eliminate the risks posed by the vehicle, system, component, separate technical unit, part or equipment that he has made available on the market.

Article 16
Obligations of distributors

1. A distributor shall verify, before making available on the market a vehicle, system, component or separate technical unit, that the vehicle, system, component or separate technical unit bears the required statutory plate or type-approval mark, that it is accompanied by the required documents and by instructions and safety information, required by Article 63, in the official language or languages of the relevant Member State, and that the manufacturer and the importer have complied with the requirements set out in Article 11(7) and Article 14(4) respectively.
 - 1a. The distributor shall immediately inform the relevant manufacturer of any complaints he receives relating to risks, suspected incidents or non-compliance issues with vehicles, systems, components, separate technical units, parts or equipment that he has made available on the market.
 - 1aa. Distributors shall ensure that, while a vehicle, system, component or separate technical unit is under their responsibility, storage or transport conditions do not jeopardise its compliance with the requirements set out in this Regulation.

Article 17

Obligations of distributors concerning their vehicles, systems, components or separate technical units that are not in conformity or concerning their vehicles, systems, components, separate technical units, parts or equipment that present a serious risk

1. Where a vehicle, system, component or separate technical unit is not in conformity with the requirements of this Regulation, the distributor shall inform the manufacturer, the importer and the approval authority that has granted the type-approval thereof and shall not make available on the market, the vehicle, system, component or separate technical unit until it has been brought into conformity.
2. Where a vehicle, system, component or separate technical unit that the distributor has made available on the market is not in conformity with this Regulation, he shall inform the manufacturer, the importer and the approval authority that has granted the type-approval.
3. Where the vehicle, system, component, separate technical unit, part or equipment presents a serious risk, the distributor shall immediately provide detailed information on that serious risk to the manufacturer, the importer and the approval and market surveillance authorities of the Member States in which that vehicle, system, component, separate technical unit, part or equipment has been made available on the market.

The distributor shall also inform them of any action taken and give details of corrective measures taken by the manufacturer.

4. The distributor shall, following a reasoned request from a national authority, cooperate with that authority on any action taken in accordance with Article 20 of Regulation (EC) No 765/2008 to eliminate the risks posed by the vehicle, system, component, separate technical unit, part or equipment that he has made available on the market.

Article 18

Cases in which obligations of manufacturers apply to importers and distributors

An importer or distributor shall be considered a manufacturer for the purposes of this Regulation and shall be subject to the obligations of the manufacturer under Articles 8, 11 and 12, in the following cases:

- (a) where the importer or distributor makes available on the market, or is responsible for the entry into service of a vehicle, system, component or separate technical unit under its name or trademark or modifies a vehicle, system, component or separate technical unit in such a way that it may no longer comply with the applicable requirements;
- (b) where the importer or distributor makes available on the market or is responsible for the entry into service of a system, component or separate technical unit on the basis of UNECE approvals issued to manufacturers outside the Union, and no manufacturer's representative in the territory of the Union can be identified.

Article 19

Identification of economic operators

Upon a request of an approval authority or a market surveillance authority, for a period of ten years after the placing on the market of a vehicle and for a period of five years after the placing on the market of a system, component, separate technical unit, part or equipment, economic operators shall provide information on the following:

- (a) the identity of any economic operator who has supplied them with a vehicle, system, component, separate technical unit, part or equipment;
- (b) the identity of any economic operator to whom they have supplied a vehicle, system, component, separate technical unit, part or equipment.

CHAPTER III

PROCEDURES FOR EU TYPE-APPROVAL

Article 20 *Procedures for EU type-approval*

1. Where applying for a whole-vehicle type-approval, the manufacturer may choose one of the following procedures:

step-by-step type-approval;

- (a) single-step type-approval;
- (b) mixed type-approval.

In addition, the manufacturer may choose multi-stage type-approval for an incomplete or completed vehicle.

2. Without prejudice to the requirements of the regulatory acts listed in Annex IV, for system type-approval, component type-approval and separate technical unit type-approval only the single-step type-approval is applicable.

3. Multi-stage type-approval shall be granted in respect of an incomplete or completed type of vehicle that, having regard to the state of completion of the vehicle, conforms to the particulars in the information folder provided for in Article 22 and meets the technical requirements laid down in the relevant regulatory acts listed in Annex IV.

The multi-stage type-approval shall also apply to complete vehicles converted or modified by another manufacturer after their completion.

4. The EU type-approval for the final stage of completion shall be granted only after the approval authority has verified that the type of vehicle approved at the final stage meets at the time of the approval all applicable technical requirements, in accordance with the procedures laid down in Annex XVII. Verification shall include a documentary check of all requirements covered by an EU type-approval for an incomplete type of vehicle granted in the course of a multi-stage procedure, including where granted for a different category of vehicle.

5. The choice of type-approval referred to in paragraph 1 shall not affect the applicable requirements with which the approved type of vehicle has to comply with at the time of issuing of the whole-vehicle type-approval.
6. Multi-stage type-approval may also be used by a single manufacturer, provided it is not used to circumvent the requirements applicable to vehicles built in a single stage. Vehicles built by a single manufacturer are not considered to be built in multiple stages for the purposes of Articles 39, 40 and 47 of this Regulation.
7. The manufacturer shall make available to the approval authority as many vehicles, components or separate technical units as are required under the relevant regulatory acts for the performance of the required tests.

Article 21
Application for EU type-approval

1. The manufacturer shall submit to the approval authority an application for EU type-approval and the information folder referred to in Article 22.
2. Only one application may be submitted in respect of a particular type of vehicle, system, component or separate technical unit and in one Member State only.

A new application may not be submitted in another Member State in respect to the same type where:

- (a) an approval authority refused to grant an approval to that type;
- (b) an approval authority has withdrawn type-approval for that type; or
- (c) the manufacturer has revoked an application for a type-approval of that type.

The approval authority shall reject an application for a type-approval of a different type designation or of modification with respect to a previous application where the changes are not sufficient to constitute a new type.

3. A separate application shall be submitted for each type of vehicle, system, component or separate technical unit to be approved.

Article 22
Information folder

1. The information folder referred to in Article 21(1) shall include the following:
 - (a) an information document, as set out in the implementing acts adopted pursuant to paragraph 3 for single-step or mixed whole-vehicle type-approval or for step-by-step whole-vehicle type-approval or in the relevant regulatory act in case of the approval of a system, component or separate technical unit;
 - (b) all data, drawings, photographs and other relevant information;
 - (c) for vehicles, an indication of the procedure(s) chosen in accordance with Article 20(1);
 - (d) any additional information requested by the approval authority in the context of the type-approval procedure.
- 1a. The information document for whole-vehicle type approval shall contain a complete set of information on the characteristics of the type of vehicle that is needed by the approval authority to identify the type of vehicle and to properly conduct the type approval.
2. The information folder shall be supplied in an electronic format that is accepted by the approval authority. The approval authority may also accept that the information folder be supplied on paper.
3. The Commission shall adopt implementing acts to lay down the template for the information document and the information folder, including a harmonised electronic format as referred to in paragraph 2. The first such implementing act shall be adopted by [PO: please insert 24 months after entry into force of this Regulation]. Those implementing acts shall be adopted in accordance with the examination procedure referred to in Article 87(2).

Article 23
Additional information to be provided with an application
for EU type-approvals

1. An application for a step-by-step type-approval shall, in addition to the information folder referred to in Article 22, be accompanied by the complete set of EU or UNECE type-approval certificates and their attachments, required pursuant to the regulatory acts listed in Annex IV.

In case of a system type-approval, component type-approval or separate technical unit type-approval, pursuant to the regulatory acts listed in Annex IV, the approval authority shall have access to the information folder and, if applicable, the type-approval certificates and their attachments until the whole-vehicle type-approval is either issued or refused.

2. An application for a mixed type-approval shall, in addition to the information folder referred to in Article 22, be accompanied by the EU or UNECE type-approval certificates and their attachments, required pursuant to the regulatory acts listed in Annex IV.

For systems for which no EU or UNECE type-approval certificate has been presented, the application shall, in addition to the information folder referred to in Article 22, be accompanied by the information specified in the implementing acts adopted pursuant to Article 22(3), required for the approval of those systems during the vehicle approval phase, and by a test report instead of the EU or UNECE type-approval certificate.

3. An application for a multi-stage type-approval shall be accompanied by the following information:

- (a) in the first stage, those parts of the information folder and the EU or UNECE type-approval certificates or, if applicable, the test reports that are relevant to the state of completion of the base vehicle;

- (b) in the second and subsequent stages, those parts of the information folder and the EU or UNECE type-approval certificates that are relevant to the current stage of completion, together with a copy of the EU whole-vehicle type-approval certificate for the vehicle issued at the preceding stage of construction and full details of any changes or additions that the manufacturer has made to the vehicle.

The information specified in points (a) and (b) shall be supplied in accordance with Article 22(2).

- 4. The approval authority and technical services shall have access to the software and algorithms of the vehicle as they consider necessary for the purpose of carrying out their activities.

The approval authority and technical services may also require the manufacturer to supply documentation or any additional information needed to allow for an appropriate level of understanding of the systems, including the system development process and system concept, and functions of software and algorithms necessary to verify the compliance with the requirements of this Regulation, to take a decision on which tests are required or to facilitate the execution of those tests.

- 4a. An application for a type-approval of particular type of vehicle, system, component or separate technical unit shall include a declaration by the manufacturer certifying, in accordance with the second subparagraph of Article 21(2) that:

- (a) the manufacturer has not applied for a type-approval for the same type in any other approval authority, nor has any other authority granted a corresponding approval;
- (b) no approval authority has refused to grant an approval for that type;
- (c) no approval authority has withdrawn type-approval for that type; and
- (d) the manufacturer has not revoked an application for that type.

CHAPTER IV CONDUCT OF PROCEDURES FOR EU TYPE-APPROVAL

Article 24

General provisions on conduct of procedures for EU type-approval

1. For each type of vehicle, system, component or separate technical unit, only one EU type-approval may be issued.
2. An approval authority having received an application in accordance with Article 21 shall grant an EU type-approval only after having verified all of the following:
 - (a) the conformity of production arrangements referred to in Article 29;
 - (b) that the declaration referred to in Article 23(4a) was submitted;
 - (c) the compliance of the type of vehicle, system, component or separate technical unit with the applicable requirements;
 - (d) in the case of whole-vehicle type-approvals according to the step-by-step, mixed and multi-stage procedures, the approval authority shall verify, in accordance with Article 20(4), that the systems, components and separate technical units are covered by separate valid type-approvals pursuant to the requirements applicable at the time of granting the whole-vehicle type-approval.
3. The procedures with respect to EU type-approval as set out in Annex V and with respect to multi-stage type-approval as set out in Annex XVII shall apply.

The Commission shall be empowered to adopt delegated acts in accordance with Article 88 to amend Annex V to take account of regulatory and technological developments by updating the procedures with respect to EU type-approval and Annex XVII with respect to multi-stage type-approval.

4. The approval authority shall put together an information package consisting of the information folder referred to in Article 22, accompanied by the test reports and all other documents that were added to the information folder by the technical service or by the approval authority while carrying out their tasks.

The information package may be kept electronically and shall contain an index indicating clearly all the pages and the format of each document and recording chronologically the management of the EU type-approval.

The approval authority shall keep the information package available for a period of ten years after the end of validity of the EU type-approval concerned.

5. The approval authority shall refuse to grant EU type-approval where it finds that a type of vehicle, system, component or separate technical unit, albeit in compliance with the applicable requirements, presents a serious risk to safety or may seriously harm the environment or public health. In that case, it shall immediately send to the approval authorities of the other Member States and to the Commission a detailed file explaining the reasons for its decision and setting out the evidence for its findings.
6. In accordance with Article 20, in the case of step-by-step, mixed and multi-stage type-approval procedures, the approval authority shall refuse to grant EU type-approval, where it finds that systems, components or separate technical units do not comply with the requirements set out in this Regulation.

The approval authority shall ask the approval authorities which approved the systems, components or separate technical units to act in accordance with Article 54(2).

Article 25

Notification of EU type-approvals issued, amended, refused and withdrawn

1. The approval authority shall, when issuing or amending the EU type-approval certificate, make available to the approval authorities of the other Member States, market surveillance authorities and the Commission a copy the EU type-approval certificate, together with the attachments, including the test reports referred to in Article 23, for each type of vehicle, system, component and technical unit that it has approved. That copy shall be made available by means of a common secure electronic exchange system, as set out in paragraph 5.
2. [...]
3. [...]
4. The approval authority shall without delay inform the approval authorities of the other Member States and the Commission of its refusal or withdrawal of any EU type-approval, stating the reasons for its decision, by means of a common secure electronic exchange system as set out in paragraph 5.
5. The Commission shall adopt implementing acts establishing the format of the electronic documents that have to be made available, the exchange mechanism, the procedures to inform other parties on issuing, amendments, refusals and withdrawals and the relevant security measures.

The first such implementing act shall be adopted by [*PO: please insert 24 months after entry into force of this Regulation*]. Those implementing acts shall be adopted in accordance with the examination procedure referred to in Article 87(2).

Article 26
EU type-approval certificate

1. The EU type-approval certificate shall contain, as attachments, the following:
 - (a) the information package referred to in Article 24(4);
 - (b) the test reports required by the regulatory acts referred to in Article 28(1) in the case of a system, component or separate technical unit type-approval, or the test results sheet in the case of whole-vehicle type-approval;
 - (c) in the case of a whole-vehicle type-approval, the name(s) and the specimen(s) of the signature(s) of the person(s) authorised to sign the certificates of conformity and a statement of their position in the company;
 - (d) in the case of a whole-vehicle type-approval, a filled-out specimen of the certificate of conformity of the vehicle type.
- 1a. The EU type-approval certificate shall be given a unique number in accordance with a harmonised system, which shall at least allow for the identification of the Member State granting the EU type-approval and of the requirements with which the vehicle, system, component or technical unit conforms.

2. [...]

The Commission shall adopt implementing acts to lay down the templates for the type-approval certificate, its numbering system, and the test result sheet, respectively, including providing the relevant electronic formats. The first such implementing act shall be adopted by *[PO: please insert 24 months after entry into force of this Regulation]*. Those implementing acts shall be adopted in accordance with the examination procedure referred to in Article 87(2).

3. In respect of each type of vehicle, system, component or separate technical unit, the approval authority shall:
 - (a) complete all the relevant sections of the EU type-approval certificate, including its attachments;
 - (b) compile the index to the information package;
 - (c) issue the completed EU type-approval certificate, together with its attachments, to the manufacturer without delay.
4. In case of an EU type-approval the validity of which has been restricted in accordance with Articles 37 and 41 and Part III of Annex IV, or in relation to which certain provisions of this Regulation or of the regulatory acts referred to in Annex IV do not apply, the EU type-approval certificate shall specify those restrictions or the non-application of the relevant provisions.
5. Where the vehicle manufacturer chooses the mixed type-approval procedure, the approval authority shall complete the information package with the references to the test reports required by the regulatory acts referred to in Article 28(1) for the systems, components or separate technical units for which no EU type-approval certificate has been issued, and shall clearly identify against which technical requirements of the regulatory acts listed in Annex IV the vehicle was tested.
6. Where the vehicle manufacturer chooses the single-step type-approval procedure, the approval authority shall append to the EU type-approval certificate a list of relevant regulatory acts in accordance with the template provided in the implementing acts adopted pursuant to paragraph 2.

Article 27

Specific provisions concerning EU type-approvals for systems, components or separate technical units

1. An EU type-approval shall be granted in respect of a system, component or separate technical unit that conforms to the particulars in the information folder provided for in Article 22 and that meets the technical requirements laid down in the relevant acts listed in Annex IV.
2. Where components or separate technical units, whether or not intended for repair, servicing or maintenance, are also covered by a system type-approval with respect to a vehicle, no additional component or separate technical unit type-approval shall be required, unless provided for under the relevant acts listed in Annex IV.
3. Where a component or separate technical unit fulfils its function or offers a specific feature only in conjunction with other parts of the vehicle, thereby making it possible to verify compliance only where the component or separate technical unit is operating in conjunction with those other vehicle parts, the scope of the component or the separate technical unit EU type-approval shall be restricted accordingly.

In those cases, the EU type-approval certificate shall specify any restriction on the use of the component or the separate technical unit and shall indicate the special conditions for its fitting in a vehicle.

Where that component or separate technical unit is fitted in a vehicle, the approval authority shall verify, at the time of the approval of the vehicle, compliance with any applicable restrictions on the use or conditions for fitting.

Article 28
Tests required for EU type-approval

1. For the purpose of EU type-approvals the approval authority shall verify compliance with the technical requirements of this Regulation by means of appropriate tests, performed by designated technical services.
 - 1a. The fundamental elements of the tests, including the technical requirements, compliance with which was verified by the tests, shall be noted in a test report.
 - 1b. The format of the test reports shall comply with the general requirements as laid down by the Commission by means of implementing acts. The first such implementing act shall be adopted by [PO: please insert 24 months after entry into force of this Regulation]. Those implementing acts shall be adopted in accordance with the examination procedure referred to in Article 87(2).
2. The manufacturer shall provide the technical services concerned with the vehicles, systems, components or separate technical units that are required under the relevant acts listed in Annex IV for the performance of the required tests.
3. The required tests shall be performed on those vehicles, systems, components and separate technical units that are representative of the type to be approved.
 - 3a. Where a range of values is provided for parameters and conditions used to perform the appropriate tests referred to in paragraph 1, the technical services may choose any value within the provided range.
4. At the request of the manufacturer and subject to the agreement of the approval authority, virtual testing methods may be used as alternatives to the test procedures referred to in paragraph 1 in accordance with Annex XVI.
5. The Commission shall be empowered to adopt delegated acts in accordance with Article 88 to amend Annex XVI to take account of technical and regulatory developments by updating the list of regulatory acts in respect of which virtual testing methods may be used by a manufacturer or a technical service and the specific conditions under which virtual testing methods are to be used.

Article 29
Conformity of production arrangements

1. An approval authority that has granted an EU type-approval shall take the necessary measures in accordance with Annex X to verify, where necessary in cooperation with the approval authorities of the other Member States, that the manufacturer produces the vehicles, systems, components or separate technical units in conformity with the approved type.
2. An approval authority that has granted a whole-vehicle type-approval shall verify a statistically relevant number of samples of vehicles and certificates of conformity on their compliance with Articles 34 and 35 and shall verify that the data in the certificates of conformity are correct.
3. An approval authority that has granted an EU type-approval shall take the necessary measures to verify, where necessary in cooperation with the approval authorities of the other Member States, that the arrangements referred to in paragraphs 1 and 2 continue to be adequate so that vehicles, systems, components or separate technical units in production continue to conform to the approved type and certificates of conformity continue to comply with Articles 34 and 35.
4. In order to verify that a vehicle, system, component or separate technical unit conforms to the approved type, the approval authority that has granted the EU type-approval shall take the necessary measures to carry out checks or tests required for EU type-approval, on samples taken at the premises of the manufacturer, including production facilities.

In accordance with Annex X, the approval authority shall take the necessary measures to carry out those checks or tests with the frequency set out in the regulatory acts listed in Annex IV or at least once every three years if no frequency is specified in those acts.

- 4a. In order to verify that a vehicle, system, component or separate technical unit conforms to the approved type, the approval authority or the technical services shall:
- (a) in case a range of values is provided for in the test procedures laid down in the relevant regulatory acts, set the values in a random manner within the provided range when carrying out checks or tests;
 - (b) have access to the software, algorithms and documentation in accordance with Article 23(4).
- 4b. An approval authority that has granted an EU type-approval shall take the necessary measures to verify that the manufacturer complies with the obligations set out in Chapter XIV. It shall in particular verify whether, in order to comply with these obligations, the manufacturer amends or supplements the vehicle OBD and vehicle repair and maintenance information.
5. An approval authority that has granted an EU type-approval and establishes that the manufacturer no longer produces the vehicles, systems, components or separate technical units in conformity with the approved type, with the requirements of this Regulation, or establishes that the certificates of conformity no longer comply with Articles 34 and 35, even though production is continued, shall take the necessary measures to ensure that the arrangements for conformity of production are followed correctly or withdraw the type-approval. The approval authority may decide to take all necessary restrictive measures in compliance with Chapter XI.
6. The Commission shall be empowered to adopt delegated acts in accordance with Article 88 to amend Annex X to take account of technological and regulatory developments by updating the conformity of production procedures.

Article 30
Fees

1. [...]

[...]

The fees for type-approval activities shall be levied on the manufacturers who have applied for type-approval in the Member State concerned.

The Member State shall ensure that sufficient resources are available to cover the costs for market surveillance activities. Without prejudice to national legislation, those costs may be recovered by fees that can be levied by the Member State in which the vehicles, are placed on the market.

[...]

The Member States may levy administrative fees on technical services applying to be designated to cover wholly or partly the costs relating to the activities exercised by the national authorities responsible for technical services in accordance with this Regulation.

3. [...]

4. [...]

5. [...]

CHAPTER V

AMENDMENTS TO AND VALIDITY OF EU TYPE-APPROVALS

Article 31

General provisions on amendments and validity of EU type-approvals

1. The manufacturer shall inform without delay the approval authority that has granted the EU type-approval of any change in the particulars recorded in the information package, including any change in the extended documentation package in accordance with the regulatory acts listed in Annex IV.

The approval authority shall decide whether that change is to be covered by an amendment, in the form of either a revision or an extension of the EU type-approval in accordance with the procedures laid down in Article 32, or whether this change requires a new type-approval.

2. An application for that amendment shall be submitted exclusively to the approval authority that has granted the original EU type-approval.
3. Where the approval authority finds that that amendment needs the repetition of inspections or tests, it shall inform the manufacturer accordingly.
4. Where the approval authority on the basis of the inspections or tests referred to in paragraph 3 finds that the requirements for EU type-approval continue to be fulfilled, the procedures referred to in Article 32 shall apply.
5. Where the approval authority finds that the changes in the particulars recorded in the information package cannot be covered by an extension of the existing type-approval, it shall refuse to amend the EU type-approval and shall request the manufacturer to apply for a new EU type-approval.

Article 32
Revisions and extensions of EU type-approvals

1. The amendment shall be designated a ‘revision’ where the approval authority finds that despite the change in the particulars recorded in the information package the concerned type of vehicle, system, component or separate technical unit continues to comply with the applicable requirements for this type and that, therefore, no inspections or tests need to be repeated.

In that case, the approval authority shall issue without delay the revised pages of the information package as necessary, marking each revised page to show clearly the nature of the change and the date of reissue, or issue a consolidated, updated version of the information package, accompanied by a detailed description of the changes.

2. The amendment shall be designated an ‘extension’ where the approval authority finds that the particulars recorded in the information package have changed and where any of the following occurs:
 - (a) further inspections or tests are required to verify continued compliance with the requirements upon which the existing type-approval has been based;
 - (b) any information on the EU type-approval certificate, except for its attachments, has changed;
 - (c) new requirements under any act listed in Annex IV become applicable to the approved type of vehicle, system, component or separate technical unit.

In the event of an extension, the approval authority shall issue without delay an updated EU type-approval certificate denoted by an extension number, incremented in accordance with the number of successive extensions already granted. That approval certificate shall clearly state the reason for the extension and the date of reissue and validity.

3. Whenever amended pages or a consolidated, updated version are issued, the index to the information package shall be amended accordingly to show the date of the most recent extension or revision, or the date of the most recent consolidation of the updated version.
4. No extension to the type-approval of a type of vehicle shall be required if the new requirements referred to in point (c) of paragraph 2 are, from a technical point of view, irrelevant to that type of vehicle or concern categories of vehicle other than the category to which it belongs.

Article 33
Termination of validity

1. Seven years after the latest update of the information package of a EU whole-vehicle type-approval certificate for vehicles of categories M1 and N1, and ten years for vehicles of categories N2, N3, M2, M3 and O, the type approval authority shall verify that the type of vehicle complies with all the relevant regulatory acts for that type.

Where the approval authority carries out the verification mentioned in this subparagraph, it is not necessary for the tests referred to in Article 28 to be repeated.

2. An EU type-approval shall become invalid in any of the following cases:
 - (a) where new requirements applicable to the approved type of vehicle, system, component or separate technical unit become mandatory for the making available on the market, registration or entry into service and the type-approval cannot be extended in accordance with point (c) of Article 32(2);
 - (aa) where the verification carried out in accordance with paragraph 1 concludes that the vehicle does not comply with all the relevant regulatory acts for that type;

- (b) where the production of vehicles in conformity with the approved type of vehicle is definitely discontinued on a voluntary basis, which shall be in any event deemed to occur when no vehicle of the type concerned has been produced in the previous two years. However, this type-approval of a vehicle shall continue to be valid for the purpose of registration or entry into service as long as paragraph 2(a) is not applicable;
 - (c) where the validity of the type-approval certificate expires due to a restriction referred to in Article 37(6);
 - (d) where the type-approval has been withdrawn in accordance with Article 29(5) or Article 53(1);
 - (e) where the type-approval was found to be based on false declarations, falsified test results or where data were withheld which would have led to the refusal to grant the type approval.
3. Where the whole-vehicle type-approval of only one variant within a type of vehicle or one version within a variant becomes invalid, the whole-vehicle type-approval of the type of vehicle in question shall become invalid only in so far as the particular variant or version is concerned.
4. Where production of a particular type of vehicle, system, component or separate technical unit is definitely discontinued, the manufacturer shall notify without delay the approval authority that granted the EU type-approval.

Within one month of receiving the notification referred to in the first subparagraph, the approval authority that granted the EU type-approval for the type of vehicle, system, component or separate technical unit shall inform the approval authorities of the other Member States accordingly.

5. Where a type-approval certificate is due to become invalid, the manufacturer shall notify without delay the approval authority that granted the type-approval thereof.
6. Upon reception of the notification made by the manufacturer, the approval authority that granted the type-approval shall communicate without delay to the approval authorities of the other Member States and the Commission all relevant information for the making available on the market, registering or entering into service of vehicles, systems, components or separate technical units where appropriate.

For vehicles, the communication shall specify the date of production and the vehicle identification number ('VIN'), as defined in Article 2 of Commission Regulation (EU) 19/2011¹⁷, of the last vehicle produced.

CHAPTER VI

CERTIFICATE OF CONFORMITY AND MARKINGS

Article 34

Provisions on the certificate of conformity in a paper format

1. The manufacturer shall issue a certificate of conformity as a paper document to accompany each vehicle, whether complete, incomplete or completed that is manufactured in conformity with the approved type of vehicle. For that purpose the manufacturer shall use the template set out in the implementing acts adopted pursuant to paragraph 2.

The certificate of conformity describe the main characteristics of the vehicle as well as its technical performance in concrete terms.

The certificate of conformity in paper format shall include the date of manufacture of the vehicle. It shall be designed to prevent forgery.

¹⁷ Commission Regulation (EU) 19/2011 concerning type-approval requirements for the manufacturer's statutory plate and for the vehicle identification number of motor vehicles and their trailers and implementing Regulation (EC) No 661/2009 of the European Parliament and of the Council concerning type-approval requirements for the general safety of motor vehicles, their trailers and systems, components and separate technical units intended therefor (OJ L 8, 12.1.2011, p. 1).

The certificate of conformity in paper format shall be delivered free of charge to the buyer together with the vehicle. Its delivery may not be made dependent on an explicit request or the submission of additional information to the manufacturer.

- 1a. From [date of entry into force + 8 years] the manufacturer shall be exempted from the obligation in paragraph 1 to issue the certificate of conformity in paper format to accompany each vehicle, if the manufacturer makes the certificate of conformity available as structured data in accordance with the Article 35.
- 1b. For a period of ten years after the production date of the vehicle, the manufacturer shall, at the request of the vehicle owner, issue a duplicate of the certificate of conformity in paper format against a payment not exceeding the cost of issuing it. The word ‘duplicate’ shall be clearly visible on the face of any duplicate certificate.

2. [...]

In order to create uniform conditions for implementing paragraph 1, the Commission shall adopt implementing acts concerning the certificate of conformity in paper format setting out, in particular:

- (a) the template for the certificate of conformity,
- (b) the security elements to prevent forgery of the certificate of conformity,
- (c) the specification concerning the manner of signing of the certificate of conformity.

The first such implementing act shall be adopted by 1 September 2020 in accordance with the examination procedure referred to in Article 87(2).

3. The certificate of conformity in paper format shall be drawn up in at least one of the official languages of the Union.

4. The person(s) authorised to sign certificates of conformity in paper format shall be employed by the manufacturer and shall be duly authorised to engage the legal responsibility of the manufacturer with respect to the design and the construction of the vehicle or to the conformity of its production.
5. The certificate of conformity in paper format shall be completed in its entirety and shall not contain restrictions as regards the use of the vehicle other than those provided for in this Regulation or any of the regulatory acts listed in Annex IV.
 - 5a. In case of an incomplete base vehicle, the manufacturer shall fill in only fields of the certificate of conformity in a paper format that are relevant with regards to the completeness of the vehicle.
 - 5b. In case of an incomplete or completed vehicle, the manufacturer shall fill in only those fields of the certificate of conformity in paper format that concern the additions or changes carried out at the current stage of approval and, where applicable, shall attach all certificates of conformity in paper format delivered at the previous stages.
6. [...]

Article 35

Provisions on the certificate of conformity in electronic format

1. Without prejudice to Article 34(1), the manufacturer may make available without undue delay after the date of manufacture of the vehicle and free of charge, the certificate of conformity to the approval authority that has issued the whole-vehicle type-approval as structured data in accordance with paragraph 6.

The approval authority shall make available the certificate of conformity as structured data in accordance with paragraph 6, where it can be accessed by the approval authorities, market surveillance authorities and registration authorities of the Member States and by the Commission.

2. The manufacturer may be exempted from the obligation in paragraph 1 for types of vehicles which have national small series type approval according to Article 40.
3. The approval authority receiving the certificate of conformity as structured data in electronic format shall give read-only access in accordance with Article 10a(3), and in the case of vehicles built in multiple stages to the manufacturer of the subsequent stage.
[...]
4. All data exchange according to this Article shall be performed by means of a secure data exchange protocols.
5. Member States shall establish the organisation and structure of their data network to enable data reception of the certificates of conformity as structured data in electronic format preferably by making use of existing systems for the exchange of structured data in accordance with paragraph 6 with effect from 1 September 2025.
6. In order to create uniform conditions for implementation of this Article and taking into account the data required on the certificate of conformity in paper format, the Commission shall adopt implementing acts concerning the certificate of conformity as structured data in electronic format setting out, in particular:
 - (a) the basic format and structure of the data elements of the certificates of conformity in electronic format and the messages used in the exchange,
 - (b) minimum requirements for secure data exchange including prevention of data corruption and data misuse and measures to guarantee the authenticity of the electronic data, such as the use of a digital signature,
 - (c) the means of exchange of the data records of the certificate of conformity in electronic format,

- (d) minimum requirements for the vehicle-specific unique identifier and the form of information for the buyer according to paragraph 3,
- (e) access in accordance with paragraph 3,
- (f) exemptions for the manufacturers of particular vehicle categories and vehicle types produced in small series.

The first such implementing act shall be adopted by 1 September 2020 in accordance with the examination procedure referred to in Article 87(2).

- 7. Without prejudice to Article 34 (1), manufacturers shall issue certificates of conformity in accordance with this Article on a compulsory basis with effect from [PO please insert: date of entry into force + 8 years].
- 8. Member States shall be able to perform exchange of certificates of conformity in electronic format in accordance with this Article with the authorities of the other Member States with effect at the latest from [PO please insert: date of entry into force + 8 years].
- 8a. After the date referred to in Article 35(8) the manufacturer shall issue a duplicate of the certificate of conformity in paper format in exceptional cases upon request of a national authority.

Article 36

Manufacturer's statutory and additional plates, markings and type-approval mark of components or separate technical units

1. The manufacturer of a vehicle shall affix to every vehicle manufactured in conformity with the approved type a statutory plate, where relevant additional plates, and indications or symbols, with the markings required in this Regulation and by the relevant regulatory acts listed in Annex IV.
2. The manufacturer of a component or separate technical unit shall affix to every component or separate technical unit manufactured in conformity with the approved type, whether or not it is part of a system, the type-approval mark required by the relevant regulatory acts listed in Annex IV.

Where no such type-approval mark is required, the manufacturer shall affix to the component or separate technical unit at least the trade name or trade mark of the manufacturer, and the type number or an identification number.

3. The EU type-approval mark shall be in accordance with the implementing acts adopted by the Commission. The first such implementing act shall be adopted by [PO please insert: 24 months after entry into force of this Regulation]. Those implementing acts shall be adopted in accordance with the examination procedure referred to in Article 87(2).
- 3a. Economic operators shall only place on the market vehicles, components or separate technical units which are marked in a way that complies with this Regulation.

CHAPTER VII NEW TECHNOLOGIES OR NEW CONCEPTS

Article 37 Exemptions for new technologies or new concepts

1. The manufacturer may apply for an EU type-approval in respect of a type of vehicle, system, component or separate technical unit that incorporates new technologies or new concepts that are incompatible with one or more regulatory acts listed in Annex IV.
2. The approval authority shall grant the EU type-approval referred to in paragraph 1 where all of the following conditions are met:
 - (a) the application for the EU type-approval states the reasons why the new technologies or new concepts make the vehicle, system, component or separate technical unit incompatible with one or more regulatory acts listed in Annex IV;
 - (b) the application for the EU type-approval describes the safety and environmental implications of the new technology or new concept and the measures taken in order to ensure at least an equivalent level of safety and environmental protection as that provided by the requirements from which exemption is sought;
 - (c) test descriptions and results are presented proving that the condition in point (b) is met.
3. The granting of EU type-approvals exempting new technologies or new concepts shall be subject to authorisation by the Commission. That authorisation shall be given by means of an implementing act. That implementing act shall be adopted in accordance with the examination procedure referred to in Article 87(2).
4. Pending the decision on authorisation by the Commission, the approval authority may issue a provisional EU type-approval, valid only in the territory of the Member State of that approval authority, in respect of a type of vehicle covered by the exemption sought. The approval authority shall inform without delay the Commission and the other Member States thereof by means of a file containing the information referred to in paragraph 2.

The provisional nature and the limited territorial validity of the EU type-approval shall be apparent from the heading of the type-approval certificate and the heading of the certificate of conformity.

5. Approval authorities of other Member States may decide to accept the provisional EU type-approval referred to in paragraph 4 within their territory, provided they inform in writing the approval authority that granted the provisional EU type-approval of their acceptance.
6. Where appropriate, the authorisation of the Commission referred to in paragraph 3 shall specify whether it is subject to any restrictions, in particular with regard to the maximum number of vehicles covered. In all cases, the EU type-approval shall be valid for at least 36 months.
7. Where the Commission refuses authorisation referred to in paragraph 3, the approval authority shall immediately inform the holder of the provisional type-approval referred to in paragraph 4 that the provisional EU type-approval approval shall be revoked six months after the date of the Commission's refusal.

However, vehicles that have been manufactured in conformity with the provisional EU type-approval before it ceased to be valid may be placed on the market, registered or entered into service in any Member State that has accepted the provisional EU type-approval in accordance with paragraph 5.

Article 38

Subsequent adaptation of regulatory acts

1. Where the Commission has authorised the granting of an EU type-approval in accordance with Article 37, it shall immediately take the necessary steps to adapt the regulatory acts concerned to the latest technological developments.

Where the exemption under Article 37 relates to a UNECE regulation, the Commission shall make proposals to amend the relevant UNECE regulation in accordance with the procedure applicable under the Revised 1958 Agreement.

2. Once the relevant regulatory acts have been amended, any restriction in the Commission decision authorising the granting of an EU type-approval shall be lifted.
3. Where the necessary steps to adapt the regulatory acts referred to in paragraph 1 have not been taken, the Commission may authorise the extension of the validity of the provisional EU type-approval by means of a decision and at the request of the Member State that granted the provisional EU type-approval. Those implementing acts shall be adopted in accordance with the examination procedure referred to in Article 87(2).

CHAPTER VIII

VEHICLES PRODUCED IN SMALL SERIES

Article 39

EU type-approval of vehicles produced in small series

1. At the request of the manufacturer and within the quantitative annual limits for vehicle categories M, N, O set out in Section 1 of Annex XII, Member States shall grant an EU type-approval for a type of vehicle produced in small series that satisfies at least the requirements set out in Appendix 1 to Part I of Annex IV.
2. Paragraph 1 shall not apply to special purpose vehicles.
- 2a. The EU type-approval certificate for vehicles produced in small series shall be given a unique number in accordance with a harmonised system, which shall at least allow for the identification of the Member State granting the EU type-approval and of the requirements with which the vehicle, system, component or technical unit conforms.
3. EU type-approval certificates for vehicles produced in small series shall be in accordance with the template and the numbering system laid down by the Commission by means of implementing acts. Those implementing acts shall be adopted in accordance with the examination procedure referred to in Article 87(2).
4. The Commission shall be empowered to adopt delegated acts in accordance with Article 88 to supplement Appendix 1 of Part I of Annex IV to set out the technical requirements for vehicle categories M, N, O and to amend accordingly Annex XII as regards the quantitative annual limits.

Article 40

National type-approval of vehicles produced in small series

1. The manufacturer may apply for a national type-approval of vehicles produced in small series within the quantitative annual limits set out in Section 2 of Annex XII. Those limits shall apply to the making available on the market, registration or entry into service of vehicles of the approved type on the market of each Member State in a given year.
2. Member States may decide to exempt any type of vehicle referred to in paragraph 1 from compliance with one or more of the provisions of this Regulation or with one or more of the requirements laid down in the regulatory acts listed in Annex IV, provided that those Member States lay down relevant alternative requirements.
3. For the national type-approval of vehicles produced in small series, the approval authority shall accept systems, components or separate technical units that are type-approved in accordance with the acts listed in Annex IV.
- 3a. The national type-approval certificate for vehicles produced in small series shall be given a unique number in accordance with a harmonised system, which shall at least allow for the identification of the Member State granting the type-approval and for characterising the approval as one granted for a national small series.
4. The national type-approval certificate of vehicles produced in small series shall be in accordance with the template and the harmonised numbering system laid down by the Commission by means of implementing acts. It shall bear the heading ‘National small series vehicle type-approval certificate’ and shall specify the content and the nature of the exemptions granted pursuant to paragraph 2. Those implementing acts shall be adopted in accordance with the examination procedure referred to in Article 87(2). Until such time as the Commission adopts such an implementing act, Member States may continue to determine the format of the national certificates.

Article 41

Validity of a national type-approval of vehicles produced in small series

1. The validity of a national type-approval of vehicles produced in small series shall be restricted to the territory of the Member State of the approval authority that has granted that type-approval.
2. At the request of the manufacturer, the approval authority shall send to the approval authorities of the Member States designated by the manufacturer a copy of the type-approval certificate, including the relevant parts of the information package, either by registered or electronic mail.
3. [...]

The approval authorities of the Member States shall accept the national type-approval, unless they have reasonable grounds to believe that the national technical requirements in accordance with which the type of vehicle has been approved are not equivalent to their own.

4. Within two months of receipt of the documents referred to in paragraph 2, the approval authorities of Member States designated by the manufacturer shall communicate to the approval authority that has granted the national type-approval their decision to accept the type-approval or not. Where no objection has been raised within this period of two months the national type-approval shall be considered as accepted.
5. At the request of an applicant who wishes to place on the market, register or enter in to service in another Member State a vehicle with national type-approval of vehicles produced in small series, the approval authority that granted the national type-approval of vehicles produced in small series shall provide the national authority of the other Member State with a copy of the type-approval certificate, including the relevant parts of the information package.

The national authority of the other Member State shall permit the placing on the market, registration or entry into service of such vehicle, unless it has reasonable grounds to believe that the national technical requirements in accordance with which the type of vehicle has been approved are not equivalent to its own.

CHAPTER IX INDIVIDUAL VEHICLE APPROVALS

Article 42 EU individual vehicle approvals

1. Member States shall grant an EU individual vehicle approval for a vehicle that complies with the requirements set out in Appendix 2 to Part I of Annex IV or, for special purpose vehicles, in Part III of Annex IV. This provision shall not apply to incomplete vehicles.
2. An application for an EU individual vehicle approval shall be submitted by the owner of the vehicle, the manufacturer or by the manufacturer's representative or the importer.
3. Member States shall not carry out destructive tests to establish whether the vehicle complies with the requirements set out in paragraph 1 and shall use any relevant information provided by the applicant for that purpose.
- 3a. The EU individual vehicle approval certificate shall be given a unique number in accordance with a harmonised system, which shall at least allow for the identification of the Member State granting the EU approval.
4. An EU individual vehicle approval certificate shall be in accordance with the template and the numbering system laid down by the Commission by means of implementing acts. The first such implementing act shall be adopted by [PO: please insert 24 months after entry into force of this Regulation]. Those implementing acts shall be adopted in accordance with the examination procedure referred to in Article 87(2).
5. Member States shall permit the placing on the market, registration or entry into service of vehicles with a valid EU individual vehicle approval certificate.
6. The Commission shall be empowered to adopt delegated acts in accordance with Article 88 to supplement Part I of Annex IV to set out the technical requirements for new vehicles of categories M, N, O.

Article 43
National individual vehicle approvals

1. Member States may decide to exempt a particular vehicle, whether unique or not, from compliance with one or more of the provisions of this Regulation or with the requirements laid down in the regulatory acts listed in Annex IV, provided that those Member States impose relevant alternative requirements.
2. An application for national individual vehicle approval shall be submitted by the owner of the vehicle, the manufacturer or by the manufacturer's representative or the importer.
3. Member States shall not carry out destructive tests to establish whether the vehicle complies with the alternative requirements set out in paragraph 1 and shall use any relevant information provided by the applicant for that purpose.
4. For the purpose of a national individual vehicle approval, the approval authority shall accept systems, components or separate technical units that are type-approved in accordance with the acts listed in Annex IV.
5. A Member State shall issue without delay a national individual vehicle approval certificate where the vehicle conforms to the description appended to the application and satisfies the relevant alternative requirements.
- 5a. The national individual vehicle approval certificate shall be given a unique number in accordance with a harmonised system, which shall at least allow for the identification of the Member State granting the EU type-approval and of the requirements with which the vehicle, system, component or technical unit conforms.
6. A national individual vehicle approval certificate shall be in accordance with the template and the numbering system laid down by the Commission by means of implementing acts. Those implementing acts shall be adopted in accordance with the examination procedure referred to in Article 87(2). Until such time as the Commission adopts such an implementing act, Member States may continue to determine the format of the national certificates.

[...]

Article 44
Validity of national individual vehicle approvals

1. The validity of a national individual vehicle approval shall be restricted to the territory of the Member State that granted the approval.
2. At the request of an applicant who wishes to make available on the market, register or enter into service in another Member State a vehicle with a national individual vehicle approval, the Member State that granted the approval shall provide the applicant with a statement of the technical provisions against which the vehicle has been approved.
3. A Member State shall permit a vehicle for which another Member State has granted a national individual vehicle approval in accordance with Article 43 to be made available on the market, registered or entered into service, unless that Member State has reasonable grounds to believe that the relevant alternative requirements against which the vehicle has been approved are not equivalent to its own or that the vehicle does not comply with those requirements.
4. The provisions of this Article may apply to vehicles that have been type-approved in accordance with this Regulation and that have been modified before their first registration or entry into service.

Article 45
Specific provisions

1. The procedures set out in Articles 42 and 43 may apply to a particular vehicle built in multi-stage.
2. The procedures set out in Articles 42 and 43 shall not replace an intermediate stage within the normal sequence of a multi-stage type-approval and shall not apply for the purposes of obtaining the first-stage approval of a vehicle.

CHAPTER X
MAKING AVAILABLE ON THE MARKET, REGISTRATION OR ENTRY
INTO SERVICE

Article 46

Making available on the market, registration or entry into service of vehicles other than end-of-series vehicles

1. Without prejudice to Articles 49 to 50, vehicles for which whole-vehicle type-approval is mandatory, or for which the manufacturer has obtained that type-approval, shall only be made available on the market, registered or enter into service if they are accompanied by a valid certificate of conformity issued in accordance with Articles 34 and 35.

[...]

Registration and entry into service of incomplete vehicles may be refused as long as the vehicles remain incomplete. Registration and entry into service of incomplete vehicles shall not be used to circumvent the provisions of Article 47.

2. [...]
3. The number of vehicles produced in small series made available on the market, registered or entered into service in the course of a single year shall not exceed the quantitative annual limits laid down in Annex XII.

Article 47

Making available on the market, registration or entry into service of end-of-series vehicles

1. Subject to the limits specified in Section B of Annex XII, and in respect only of a limited period of time, Member States may register and permit the sale or entry into service of vehicles conforming to a type of vehicle whose EU type-approval is no longer valid.

The first subparagraph shall apply only to vehicles within the territory of the Union which were covered by a valid EU type-approval at the time of their production, but which had not been registered or put into service before that EU type-approval lost its validity.

2. The option provided for in paragraph 1 shall be available, in the case of complete vehicles, for a period of twelve months from the date on which validity of the EU type-approval expired and, in the case of completed vehicles, for a period of eighteen months from that date.

3. A manufacturer who wishes to benefit from the provisions of paragraph 1 shall submit a request to the competent authority of each Member State concerned by the entry into service of the vehicles in question. The request shall specify any technical or economic reasons preventing those vehicles from complying with the new technical requirements.

The Member States concerned shall decide, within three months of receiving such a request, whether and in what number to permit the registration of those vehicles within their territory.

4. Member States shall apply appropriate measures to ensure that the number of vehicles to be registered or put into service in the framework of the procedure set out in this Article is effectively monitored.

5. [...]

6. [...]

Article 48

Making available on the market or entry into service of components and separate technical units

1. Components or separate technical units, including those intended for the aftermarket, may only be made available on the market or entered into service where they comply with the requirements of the relevant regulatory acts listed in Annex IV and are marked in accordance with Article 36.
2. Paragraph 1 shall not apply to components or separate technical units specifically constructed or designed for new vehicles that are not covered by this Regulation.
3. Member States may permit the making available on the market or entry into service of components or separate technical units that are exempted under Article 37 or to be used on vehicles covered by approvals granted under Article 39, 40, 42 and 43 concerning the component or separate technical unit in question.
4. Member States may also permit the making available on the market or entry into service of components or separate technical units to be used on vehicles that were not required to be type-approved under this Regulation or under Directive 2007/46/EC at the time those vehicles were made available on the market, registered or entered into service.
5. Member States may also permit the making available on the market or entry into service of replacement components or separate technical units to be used on vehicles that were type-approved before the entry into force of the requirements of the relevant regulatory acts listed in Annex IV, in accordance with the requirements of the relevant act applicable when those approvals were originally granted.

CHAPTER XI SAFEGUARD CLAUSES

Article 49

National evaluation regarding vehicles, systems, components or separate technical units suspected of presenting a serious risk or a non-compliance

1. Where, based on the market surveillance activities or information provided by an approval authority, manufacturers or complaints, the market surveillance authorities of one Member State have sufficient reasons to believe that a vehicle, system, component or separate technical unit covered by this Regulation presents a serious risk to the health or safety of persons or to other aspects of the protection of public interests covered by this Regulation or do not comply with the requirements laid down in this Regulation, they shall carry out an evaluation in relation to the vehicle, system, component or separate technical unit concerned covering the relevant requirements laid down in this Regulation. The relevant economic operators and the relevant approval authority shall cooperate fully with the market surveillance authorities, which shall include forwarding the results of all relevant testing in accordance with Article 29.

Article 20 of Regulation (EC) No 765/2008 shall apply to the risk assessment of the product.

3. [...]
4. [...]
5. [...]

Article 49a (new)

National procedures for dealing with vehicles, systems, components or separate technical units presenting a serious risk or non-compliance

1. Where, after having performed the evaluation pursuant to Article 49, the market surveillance authority of one Member State finds that a vehicle, system, component or separate technical unit presents a serious risk to the health or safety of persons or to other aspects of the protection of public interests covered by this Regulation, it shall require without delay the relevant economic operator to take all appropriate corrective measures without delay to ensure that the vehicle, system, component or separate technical unit concerned, when placed on the market, registered or entered into service, no longer presents that risk.
 - 1a. Where, after having performed the evaluation pursuant to Article 49, the market surveillance authority of one Member State finds that a vehicle, system, component or separate technical unit is not compliant with this Regulation, but does not present a serious risk as referred to in paragraph 1, it shall require without delay the relevant economic operator to take all appropriate corrective measures within a reasonable period. That period shall be proportionate to the non-compliance to ensure that the vehicle, system, component or separate technical unit concerned, when placed on the market, registered or entered into service, no longer presents this non-compliance.
2. The economic operator shall, in accordance with the obligations referred to in Articles 11 to 19, ensure that all appropriate corrective measures are taken in respect of all concerned vehicles, systems, components or separate technical units that it has placed on the market, registered or has entered into service in the Union.

3. Where the economic operator does not take adequate corrective measures within the relevant period referred to in paragraph 1 or 1a or where the risk requires a rapid action, the national authorities shall take all appropriate provisional restrictive measures to prohibit or restrict the making available on the market, registration or entry into service of the concerned vehicles, systems, components or separate technical units on their national market, or to withdraw them from that market or to recall them.

Article 21 of Regulation (EC) No 765/2008 shall apply to the restrictive measures referred to in this paragraph.

4. The Commission may, by means of implementing acts, elaborate a classification of the seriousness of the non-compliance and appropriate corrective measures to be taken by national authorities to ensure the uniform application of this Article. Those implementing acts shall be adopted in accordance with the examination procedure referred to in Article 87(2).

Article 50

Corrective and restrictive measures at EU level

1. The Member State taking corrective and restrictive measures in accordance with Articles 49a(1) and (3) shall notify the Commission and the other Member States without delay by means of the electronic system referred to in Article 22 of Regulation 765/2008. It shall also inform without delay the approval authority that granted the approval about its findings.

The information provided shall include all available details, in particular the data necessary for the identification of the concerned vehicle, system, component or separate technical unit, its origin, the nature of the non-compliance and the risk involved, the nature and duration of the national corrective and restrictive measures taken, and the arguments put forward by the relevant economic operator.

2. They shall also indicate whether the risk or the non-compliance is due to either of the following:
 - (a) failure of the vehicle, system, component or separate technical unit to meet requirements relating to the health or safety of persons, the protection of the environment or to other aspects of the protection of public interests covered by this Regulation;
 - (b) shortcomings in the relevant regulatory acts listed in Annex IV.
3. Member States other than the Member State initiating the procedure shall inform within one month after the notification referred to in paragraph 1 the Commission and the other Member States of any corrective or restrictive measures adopted and of any additional information at their disposal relating to the non-compliance and the risk of the vehicle, system, component or separate technical unit concerned, and, in the event of disagreement with the notified national measure, of their objections.
 - 3a. Where, within one month after the notification referred to in paragraph 1, no objection has been raised by either another Member State or the Commission in respect of a corrective or restrictive measure taken by a Member State, that measure shall be deemed justified. The other Member States shall ensure that similar corrective or restrictive measures are taken without delay in respect of the vehicle, system, component or separate technical unit concerned.
4. Where, within one month after notification referred to in paragraph 1, an objection has been raised by either another Member State or the Commission in respect of a corrective or restrictive measure taken by a Member State, or where the Commission has considered that a national measure is contrary to Union legislation, the Commission shall without delay consult the Member States concerned and the relevant economic operator or operators.

4a. On the basis of the results of that consultation, the Commission shall adopt a decision on harmonised corrective or restrictive measures at EU level by means of implementing acts. Those implementing acts shall be adopted in accordance with the examination procedure referred to in Article 87(2).

The Commission shall address its decision to all Member States and shall immediately communicate it to the relevant economic operators. The Member States shall implement the Commission decision without delay. They shall inform the Commission accordingly.

Where the Commission considers that a national measure is unjustified, the Member State concerned shall withdraw or adapt the measure, in accordance with the Commission decision referred to in paragraph 4a.

4b. Where following checks by the Commission in accordance with Article 9 of this Regulation, the Commission establishes that a corrective or restrictive measure is necessary at EU level, it shall without delay consult the Member States concerned and the relevant economic operators. The Commission shall adopt a decision in accordance with paragraph 4a.

4c. Where the risk or non-compliance is attributed to shortcomings in regulatory acts referred to in Annex IV, the Commission shall propose appropriate measures as follows:

- (a) where regulatory acts of the EU are concerned, the Commission shall propose the necessary amendments to the act concerned;
- (b) where UNECE regulations are concerned, the Commission shall propose the necessary draft amendments to the relevant UNECE regulations in accordance with the procedure applicable under the revised 1958 Agreement.

4d. Where a corrective measure is deemed justified in accordance with this Article or subject to Commission decision pursuant to paragraph 4a, those measures shall be available free of charge to holders of registrations for affected vehicles. Where repairs have been carried out at the registration holder's expense prior to the corrective measure being adopted, such repairs shall be reimbursed by the manufacturer up to the cost of the repairs required by the corrective measure.

5. [...]

Article 51

[...]

Article 52

[...]

Article 53

[...]

Article 54

Non-compliant EU type approval

1. Where an approval authority finds that a type-approval that has been granted is not compliant with this Regulation, it shall refuse to recognise such approval.
2. It shall notify the approval authority that granted the EU type-approval, the other Member States and the Commission. Where within one month after the notification, the non-compliance of the type-approval is confirmed by the approval authority that granted the EU type-approval, that approval authority shall withdraw the type-approval.
3. [...]
4. [...]
5. [...]
6. [...]
7. [...]
8. Where, within one month after the notification of the refusal of the type-approval by an approval authority, an objection has been raised by the approval authority that granted the EU type-approval, the Commission shall consult without delay the Member States, in particular the approval authority that granted the type-approval and the relevant economic operator.
[...]

8a. On the basis of that consultation, the Commission shall decide whether the refusal of recognition of EU type-approval adopted under paragraph 1 is considered justified by means of implementing acts. Those implementing acts shall be adopted in accordance with the examination procedure referred to in Article 87(2).

The Commission shall address its decision to all Member States and shall immediately communicate it to the relevant economic operators. The Member States shall implement the Commission decision without delay and inform the Commission accordingly.

8b. Where following Commission checks in accordance with Article 9 of this Regulation, the Commission establishes that a type-approval that has been granted is not compliant with this Regulation, the Commission shall consult without delay the Member States in particular the approval authority that granted the type-approval and the relevant economic operator. The Commission shall adopt a decision in accordance with paragraph 8a.

9. For products covered by a non-compliant type-approval that are already made available on the market, Articles 49 to 50 shall apply.

Article 55

*Placing on the market and entry into service of parts or equipment
that may pose a serious risk to the correct functioning of essential systems*

1. Parts or equipment that may pose a serious risk to the correct functioning of systems that are essential for the safety of the vehicle or for its environmental performance shall not be placed on the market or entered into service and shall be prohibited, unless they have been authorised by an approval authority in accordance with Article 56(1) and (4).
 - 1a. These measures should only apply to a limited number of parts or equipment, which are to be established in accordance with paragraph 3.
2. The Commission shall be empowered to adopt delegated acts in accordance with Article 88 to lay down the requirements that the parts and equipment referred to in paragraph 1 have to comply with.

Those requirements may be based on the regulatory acts listed in Annex IV or may consist of a comparison of the parts or equipment with the environmental or safety performance of the original parts or equipment, as appropriate. In either case, the requirements shall ensure that the parts or equipment do not impair the functioning of those systems that are essential for the safety of the vehicle or its environmental performance.

3. The Commission shall be-empowered to adopt delegated acts in accordance with Article 88 to amend Annex XIII to take account of technical and regulatory developments to lay down and update the list of parts or equipment on the basis of an evaluation of the following elements:
 - (a) the existence of a serious risk to the safety or environmental performance of vehicles fitted with the parts or equipment in question;
 - (b) the potential effect on consumers and aftermarket manufacturers of a possible authorisation for the parts or equipment under Article 56(1).

[...]

4. Paragraph 1 shall not apply to original parts or equipment and to parts or equipment belonging to a system that has been type-approved in accordance with the regulatory acts listed in Annex IV, except where the type-approval relates to aspects other than the serious risk referred to in paragraph 1.

For the purposes of this paragraph, original parts or equipment means parts or equipment that are manufactured according to the specifications and production standards provided by the vehicle manufacturer for the assembly of the vehicle in question.

5. Paragraph 1 shall not apply to parts or equipment that are exclusively produced for racing vehicles. Parts or equipment listed in Annex XIII that are used both in racing and on the road shall not be made available for vehicles intended for use on public roads, unless they comply with the requirements laid down in the delegated acts referred to in paragraph 2 and have been authorised by the Commission by means of implementing acts. Those implementing acts shall be adopted in accordance with the examination procedure referred to in Article 87(2).

Article 56

Related requirements for parts or equipment that may pose a serious risk to the correct functioning of essential systems

1. A manufacturer of parts or equipment may apply for the authorisation referred to in Article 55(1) by submitting to the approval authority an application accompanied by a test report that is drafted by a designated technical service and that certifies that the parts or equipment for which authorisation is sought comply with the requirements referred to in Article 55(2). The manufacturer may submit only one application for each type of part or equipment and to one approval authority only.

2. The application for the authorisation shall include details of the manufacturer of parts or equipment, the type, the identification and part numbers of the parts or equipment, the vehicle manufacturer's name, the type of vehicle and, where appropriate, the year of construction or any other information permitting the identification of the vehicle to which the parts or equipment are to be fitted.

The approval authority shall authorise the placement on the market and the entering into service of the parts or equipment where it finds, taking into account the test report referred to in paragraph 1 and other evidence, that the parts or equipment in question comply with the requirements referred to in Article 55(2).

The approval authority shall issue to the manufacturer without delay an authorisation certificate in accordance with the template and the numbering system for the authorisation certificate laid down by the Commission by means of implementing acts. Those implementing acts shall be adopted in accordance with the examination procedure referred to in Article 87(2).

[...]

3. The manufacturer shall inform without delay the approval authority that gave the authorisation of any change affecting the conditions under which the authorisation has been issued. That approval authority shall decide whether the authorisation has to be reviewed or reissued and whether further tests are necessary.

The manufacturer shall ensure that the parts or equipment are produced and continue to be produced under the conditions under which the authorisation has been issued.

4. Before issuing any authorisation, the approval authority shall verify the existence of arrangements and procedures for ensuring effective control of the conformity of production.

Where the approval authority finds that the conditions for issuing the authorisation are no longer fulfilled, it shall request the manufacturer to take the necessary measures to ensure that the parts or equipment are brought into conformity. Where necessary, it shall withdraw the authorisation.

5. Upon request of a national authority of another Member State, the approval authority that has issued the authorisation shall, within one month of the receipt of that request, send to the former a copy of the issued authorisation certificate together with its attachments by means of a common secure electronic exchange system. The copy may also take the form of a secure electronic file.
6. An approval authority that disagrees with the authorisation issued by another Member State shall bring the reasons for its disagreement to the attention of the Commission. The Commission shall take the appropriate measures in order to resolve the disagreement, which may include, where necessary, requiring the withdrawal of the authorisation, after having consulted the relevant approval authorities. Those implementing acts shall be adopted in accordance with the examination procedure referred to in Article 87(2).
7. Until the list referred to in Article 55(3) has been established, Member States may maintain national provisions dealing with parts or equipment that may affect the correct functioning of systems essential for the safety of the vehicle or its environmental performance.

Article 57

[...]

Article 58

[...]

Article 59

[...]

CHAPTER XII INTERNATIONAL REGULATIONS

Article 60

UNECE regulations required for EU type-approval

1. UNECE regulations or amendments thereto which the Union has voted in favour of or that the Union applies and that are listed in Annex IV shall be part of the requirements for the EU type-approval of vehicles, systems, components or separate technical units.
2. [...]
3. Where the Union has voted in favour of a UNECE regulation or amendments thereto for the purpose of whole-vehicle type-approval, the Commission shall adopt a delegated act in accordance with Article 88 to make the UNECE regulation or amendments thereto compulsory or to amend this Regulation, as appropriate.

That delegated act shall specify the dates of mandatory application of the UNECE regulation or amendments thereto and include transitional provisions, where appropriate, and, where applicable for the purposes of type-approval, first registration and entry into service of vehicles and making available on the market of systems, components and separate technical units.

Article 61

Equivalence of UNECE regulations for the purpose of EU type-approval

1. The UNECE regulations listed in Part II of Annex IV are recognised as being equivalent to the corresponding regulatory acts to the extent that they share the same scope and subject matter.
2. The approval authorities of the Member States shall accept type-approvals granted in accordance with the UNECE regulations referred to in paragraph 1 and, where applicable, the relevant approval marks, in place of the corresponding type-approvals and approval marks that have been granted in accordance with this Regulation and the regulatory acts adopted pursuant to this Regulation.

Article 62
Equivalence with other regulations

[...]

CHAPTER XIII
PROVISION OF TECHNICAL INFORMATION

Article 63
Information intended for users

1. The manufacturer shall not supply any technical information related to the particulars of the type of vehicle, system, component or separate technical unit or of a part or equipment provided for in this Regulation, in the delegated or implementing acts adopted pursuant to this Regulation, or in the regulatory acts listed in Annex IV, that diverges from the particulars of the type approved by the approval authority.
2. The manufacturer shall make available to users all relevant information and necessary instructions describing any special conditions or restrictions linked to the use of a vehicle, a system, a component or a separate technical unit or of a part or equipment.
3. The information referred to in paragraph 2 shall be supplied in the official language or languages of the Member State where the vehicle, system, component or separate technical unit or part or equipment is to be placed on the market, registered or is to be entered into service. It shall be provided in the owner's manual.

Article 64
Information intended for manufacturers

1. The vehicle manufacturer shall make available to the manufacturers of systems, components or separate technical units or of parts and equipment all particulars that are necessary for EU type-approval of systems, components or separate technical units or to obtain the authorisation referred to in Article 55(1).

The vehicle manufacturer may impose a binding agreement on the manufacturers of systems, components or separate technical units or of parts and equipment to protect the confidentiality of any information that is not in the public domain, including information related to intellectual property rights.

2. The manufacturer of systems, components or separate technical units or of parts and equipment shall provide the vehicle manufacturer with all detailed information on the restrictions that apply to his type-approvals and that are either referred to in Article 27(3) or imposed by a regulatory act listed in Annex IV.

CHAPTER XIV
ACCESS TO REPAIR AND MAINTENANCE INFORMATION

Article 65
Manufacturers' obligations to provide vehicle repair and maintenance information

1. Manufacturers shall provide to independent operators unrestricted, standardised and non-discriminatory access to vehicle OBD information, diagnostic and other equipment, tools including the complete references, and available downloads, of the applicable software and vehicle repair and maintenance information. Information shall be presented in an easily accessible manner in the form of machine readable and electronically processable datasets. Independent operators shall have access to the remote diagnosis services used by manufacturers and authorised dealers and repairers.

Manufacturers shall provide a standardised, secure and remote facility to enable independent repairers to complete operations that involve access to the vehicle security system.

2. Until the Commission has adopted the relevant standard through the work of the European Committee for Standardization (CEN) or comparable standardisation bodies, the vehicle OBD and vehicle repair and maintenance information shall be presented in an easily accessible manner that can be processed by independent operators with reasonable effort.

The vehicle OBD and the vehicle repair and maintenance information shall be made available on the websites of manufacturers using a standardised format or, if this is not feasible, due to the nature of the information, in another appropriate format. For independent operators other than repairers, the information shall also be given in a machine-readable format that is capable of being electronically processed with commonly available IT tools and software and which allows independent operators to carry out the task associated with their business in the aftermarket supply chain.

- 2a. In the following cases, it is sufficient that the manufacturer provides the required information in a readily accessible and prompt manner when an independent operator so requests:
 - (a) for vehicles types covered by a national type-approval of vehicles produced in small series according to Article 40;
 - (aa) for special purpose vehicles;
 - (b) for vehicle types of categories O1 and O2 that do not use diagnostic tools or a physical or wireless communication with the on-board electronic control unit(s) for the purpose of diagnostics or reprogramming of their vehicles;
 - (c) for the final stage of type-approval in a multi-stage type-approval procedure when the final stage only covers bodywork which does not contain electronic vehicle control systems and all electronic vehicle control systems of the base vehicle remain unchanged.

3. The Commission shall establish and update the appropriate technical specifications on how vehicle OBD and vehicle repair and maintenance information shall be provided. The Commission shall take into account current information technology, foreseeable vehicle technology developments, existing ISO standards and the possibility of a worldwide ISO standard.
4. The details of the requirements with regard to access to vehicle repair and maintenance information, in particular technical specifications on how vehicle repair and maintenance information shall be provided, are laid down in Annex XVIII.
5. Manufacturers shall also make training material available to independent operators and authorised dealers and repairers.
6. The manufacturer shall ensure that the vehicle repair and maintenance information shall always be accessible, except as required for maintenance purposes of the information system.
The manufacturer shall make subsequent amendments and supplements to vehicle repair and maintenance information available on its websites at the same time they are made available to authorised repairers.
7. For the purposes of manufacturing and servicing of OBD-compatible replacement or service parts and diagnostic tools and test equipment, manufacturers shall provide the relevant vehicle OBD and vehicle repair and maintenance information on a non-discriminatory basis to any interested manufacturer or repairer of component, diagnostic tool or test equipment.
8. For the purposes of the design, manufacturing and the repair of automotive equipment for alternative-fuel vehicles, manufacturers shall provide the relevant vehicle OBD and vehicle repair and maintenance information on a non-discriminatory basis to any interested manufacturer, installer or repairer of equipment for alternative-fuel vehicles.

9. Where repair and maintenance records of a vehicle are kept in a central database of the vehicle manufacturer or on its behalf, independent repairers shall have access to such records free of charge and shall be able to enter information on repair and maintenance which they have performed.
- 9a. This chapter shall not apply to vehicles insofar as they are covered by individual approvals.
10. The Commission shall be empowered to adopt delegated acts in accordance with Article 88 to amend and supplement Annex XVIII to take account of technical and regulatory developments or prevent misuse by updating the requirements concerning the access to vehicle OBD and vehicle repair and maintenance information, including the repair and maintenance activities supported by wireless wide area networks and by adopting and integrating the standards referred to in paragraphs 2 and 3.

Article 66

Obligations with regard to several type-approval holders

1. The manufacturer responsible for the respective type-approval of a system, component or separate technical unit or for a particular stage of a vehicle shall be responsible, in the event of a mixed type-approval, a step-by-step type-approval or a multi-stage type-approval, for communicating to both the final manufacturer and the independent operators the repair and maintenance information relating to the particular system, component or separate technical unit or to the particular stage.
2. In the case of multi-stage type-approval, the final manufacturer shall be responsible for providing access to vehicle OBD and vehicle repair and maintenance information regarding its own manufacturing stage(s) and the link to the previous stage(s).

Article 67

Fees for access to vehicle repair and maintenance information

1. The manufacturer may charge reasonable and proportionate fees for access to vehicle repair and maintenance information other than the records referred to in Article 65(9). Those fees shall not discourage access to that information by failing to take into account the extent to which the independent operator uses it. Access to vehicle repair and maintenance information shall be offered free of charge to national authorities, the Commission and designated technical services.
2. The manufacturer shall make available vehicle repair and maintenance information, including transactional services, such as reprogramming, or technical assistance, on an hourly, daily, monthly, and yearly basis, with fees for access to such information varying in accordance with the respective periods of time for which access is granted.

In addition to time-based access, manufacturers may offer transaction-based access, for which fees are charged per transaction and not based on the duration for which access is granted.

Where both access systems are offered by the manufacturer, independent repairers shall choose an access system, either time-based or transaction-based.

Article 68

Proof of compliance with repair and maintenance information obligations

1. The manufacturer that has applied for EU type-approval or national type-approval shall provide the approval authority with proof of compliance with Articles 65 to 70 within six months from the date of the respective type-approval.
2. Where that proof of compliance is not provided within the period referred to in paragraph 1, the approval authority shall take appropriate measures in accordance with Article 69.

Article 69

Compliance with the obligations regarding access to vehicle OBD and vehicle repair and maintenance information

1. An approval authority may at any time, whether on its own initiative, on the basis of a complaint, or on the basis of an assessment by a technical service, check the compliance of a manufacturer with Articles 65 to 70, and with the terms of the Certificate on Access to Vehicle OBD and Vehicle Repair and Maintenance Information laid down in Appendix 1 of Annex XVIII.
2. Where an approval authority finds that the manufacturer has failed to comply with his obligations regarding access to vehicle OBD and vehicle repair and maintenance information, the approval authority that granted the relevant type-approval shall take appropriate measures to remedy the situation.

Those measures may include withdrawal or suspension of the type-approval, fines, or other measures adopted pursuant to Article 89.

3. Where an independent operator or a trade association representing independent operators files a complaint to the approval authority on the failure of the manufacturer to comply with Articles 65 to 70, the approval authority shall carry out an audit in order to verify compliance by the manufacturer. The approval authority shall request the approval authority that granted the whole vehicle type-approval to investigate the complaint and subsequently request evidence from the vehicle manufacturer that its system is in compliance with the Regulation. The results of that investigation shall be communicated within three months of the request to the national approval authority and the independent operator or trade association concerned.
4. When carrying out the audit, the approval authority may ask a technical service or any other independent expert to carry out an assessment to verify whether the obligations concerning access to vehicle OBD and vehicle repair and maintenance information have been met.

Article 70
Forum on Access to Vehicle Information

1. The Forum on Access to Vehicle Information regarding access to vehicle OBD and vehicle repair and maintenance information, established in accordance with Article 13(9) of Regulation (EC) No 692/2008, shall also cover all vehicles under the scope of this Regulation. It shall carry out its activities in accordance with the provisions laid down in Annex XVIII.
2. The Forum shall consider whether access to-vehicle OBD and vehicle repair and maintenance information affects the advances made in reducing vehicle theft and shall make recommendations for improving the requirements relating to access to this information. In particular, the Forum shall advise the Commission on the introduction of a process for approving and authorising independent operators by accredited organisations to access information on vehicle security.

The Commission may decide to keep the discussions and findings of the Forum confidential.

CHAPTER XV
ASSESSMENT, DESIGNATION, NOTIFICATION
AND MONITORING OF TECHNICAL SERVICES

Article 71
Type approval authority responsible for technical services

1. The approval authority designated by the Member State in accordance with Article 6(1a), hereinafter referred to as the 'type-approval authority', shall be responsible for the assessment, designation, notification and the monitoring of technical services, including, where appropriate, the subcontractors or subsidiaries of those technical services. The type-approval authority may decide that the assessment and monitoring of technical services and, where appropriate, of the subcontractors or subsidiaries of those technical services, shall be carried out by a national accreditation body within the meaning of and in accordance with Regulation (EC) No 765/2008.

- 1a. Type-approval authorities shall not be subject to peer-evaluation when they designate all their technical services exclusively on the basis of accreditation of the technical services.
- 1b. Type-approval authorities shall be subject to peer-evaluation in respect of any activity which they carry out related to the assessment and monitoring of technical services which have been designated.

Peer-evaluations shall cover the assessments that have been carried out by type-approval authorities of the entire or partial operations of technical services. This assessment shall include the competence of the personnel, the correctness of the test and inspection methodology and the correctness of test results based on a defined scope of regulatory acts listed in Part I of Annex IV, in accordance with Article 77(1b),

Activities related to the assessment and monitoring of technical services dealing only with national individual approvals in accordance with Article 43 and national small series in accordance with Article 40 are exempted from the peer-evaluation.

Any assessment by type-approval authorities of accredited technical services shall be exempted from peer-evaluation.

2. [...]
3. [...]
4. The type-approval authority shall not provide consultancy services on a commercial or competitive basis.
5. [...]
6. The type-approval authority shall have a sufficient personnel at its disposal to carry out the tasks laid down in this Regulation.

7. Member States shall provide the Commission, the Forum established by Article 10 and, upon request, the other Member States with information on their procedures for the assessment, designation and notification of technical services and for the monitoring of technical services, and of any changes thereto.
- 7a. Type-approval authorities subject to peer evaluation shall establish procedures for internal audits as set out in Appendix 2 of Annex V. Internal audits shall be performed at least once a year. However, the frequency of internal audits may be reduced if the type-approval authority can demonstrate that its management system has been effectively implemented and has proven stability.
- 7b. Peer evaluation of a type-approval authority shall be carried out by two type-approval authorities of other Member States and shall be carried out at least once every five years. The Commission may participate in the peer evaluation team and decide on its participation on the basis of a risk assessment analysis.

The evaluation shall be carried out under the responsibility of the evaluated authority and include an on-site visit to a technical service selected to the discretion of the peer evaluation team.

- 7c. Taking duly into account the considerations of the Forum in accordance with Article 10, the Commission may adopt implementing acts setting out a plan for the peer evaluations covering a period of at least 5 years, laying down criteria concerning the composition of the peer evaluation team, the methodology used for the evaluation, the schedule, periodicity and the other tasks related to the evaluation. Those implementing acts shall be adopted in accordance with the examination procedure referred to in Article 87(2).

- 7d. The outcome of the peer-evaluations shall be examined by the Forum. The Commission shall draw up a summary of the outcome and make it public.
8. [...]
9. [...]
10. [...]
11. The Commission may adopt implementing acts to lay down the model for the provision of information on the procedures of the Member States referred to in paragraph 7. Those implementing acts shall be adopted in accordance with the examination procedure referred to in Article 87(2).

Article 72
Designation of technical services

1. The type-approval authorities shall designate technical services for one or more of the following categories of activities, depending on their field of competence:
- (a) category A: tests referred to in this Regulation and in the acts listed in Annex IV that those technical services carry out in own facilities;
 - (b) category B: supervision of the tests, including test preparation, referred to in this Regulation and in the acts listed in Annex IV, where those tests are performed in the manufacturer's facilities or in the facilities of a third party;
 - (c) category C: assessment and monitoring on a regular basis of the procedures of the manufacturer for controlling conformity of production;
 - (d) category D: supervision or performance of tests or inspections for the surveillance of conformity of production.

Type approval authorities that are not subject to peer evaluation in accordance with Article 71(7a), shall not be included in any of the activities related to the peer evaluation team.

2. A Member State may designate a type-approval authority as a technical service for one or more of the categories of activities referred to in paragraph 1.
3. A technical service shall be established under the national law of a Member State and have legal personality, except for a technical service belonging to a type-approval authority and for an accredited in-house technical service of a manufacturer, as referred to in Article 76.
4. A technical service shall take out liability insurance for its activities unless that liability is assumed by the Member State in accordance with national law, or the Member State itself is directly responsible for the conformity assessment.
5. Technical services of a third country, other than those designated in accordance with Article 76, may be designated and notified for the purposes of Article 78 only where a bilateral agreement between the Union and the third country concerned provides for the possibility of designating those technical services. This shall not prevent a technical service established under the national law of a Member State in accordance with paragraph 3 from establishing subsidiaries in third countries, provided that the subsidiaries are directly managed and controlled by the designated technical service.

Article 73

Independence of the technical services

1. A technical service, including its personnel, shall be independent and shall carry out the activities for which it has been designated with the highest degree of professional integrity and the requisite technical competence in the specific field in which it operates and shall be free from all pressures and inducements, particularly financial, that might influence its judgment or the results of its assessment activities, especially such pressures or inducements emanating from persons or groups of persons with an interest in the results of those activities.
2. A technical service shall be a third-party organisation or body that is not involved in the process of design, manufacturing, supply or maintenance of the vehicle, system, component or separate technical unit it assesses, tests or inspects.

An organisation or body belonging to a business association or professional federation representing undertakings that are involved in the design, manufacturing, supply or maintenance of the vehicles, systems, components or separate technical units that it assesses, tests or inspects, may be considered as fulfilling the requirements of the first subparagraph, provided that its independence and the absence of any conflict of interest are demonstrated to the type-approval authority of the relevant Member State.

3. A technical service, its top-level management and the personnel responsible for carrying out the activities for which they are designated in accordance with Article 72(1) shall not design, manufacture, supply, or maintain the vehicles, systems, components or separate technical units that they assess, nor represent parties engaged in those activities. This shall not preclude the use of those vehicles, systems, components or separate technical units that are necessary for the operation of the technical service or the use of such vehicles, systems, components or separate technical units for personal purposes.
4. A technical service shall ensure that the activities of its subsidiaries or subcontractors do not affect the confidentiality, objectivity or impartiality of the categories of activities for which it has been designated.
5. The personnel of a technical service shall observe professional secrecy with regard to all information obtained in carrying out their tasks under this Regulation, except in relation to the type-approval authority and, where relevant, to the national accreditation body, or where required by Union or national law.

Article 74
Competence of the technical services

1. A technical service shall be capable of carrying out all the activities for which it is applying to be designated in accordance with Article 72(1). It shall demonstrate to the type approval authority or to the national accreditation body carrying out the assessment or monitoring of that technical service that it has all of the following:
 - (a) its personnel has the appropriate skills, the specific technical knowledge, the vocational training and sufficient and appropriate experience to perform the activities for which it is seeking to be designated;
 - (b) it possesses the descriptions of the procedures relevant for the performance of the activities for which it is seeking to be designated, taking due account of the degree of complexity of the technology of the relevant vehicle, system, component or separate technical unit in question, as well as the mass or serial nature of the production process. The technical service shall demonstrate the transparency and reproducibility of those procedures;
 - (c) it has the necessary means to perform the tasks connected with the categories of activities for which it is seeking to be designated and that it has access to all necessary equipment or facilities.
2. A technical service shall also demonstrate that it has the appropriate skills, the specific technical knowledge and proven experience to carry out tests and inspections for assessing the conformity of the vehicles, systems, components and separate technical units with this Regulation and its compliance with the standards listed in Appendix 1 to Annex V. However, the standards listed in Appendix 1 to Annex V do not apply for the purposes of the last stage of a national multi-stage procedure as referred to in Article 45(1).

- 3.- The Commission shall be empowered to adopt delegated acts in accordance with Article 88 to amend Annex V concerning the requirements and assessment of the technical services.

Article 75

Subsidiaries of and subcontracting by technical services

1. Technical services may subcontract, with the agreement of their type-approval authority, some of the categories of activities for which they have been designated in accordance with Article 72(1), or have those activities carried out by a subsidiary.
2. Where a technical service subcontracts specific tasks from the categories of activities for which it has been designated or has recourse to a subsidiary to perform those tasks, it shall ensure that the subcontractor or the subsidiary complies with the requirements set out in Articles 72, 73 and 74 and it shall inform the type-approval authority thereof.
3. Technical services shall take full responsibility for the tasks performed by their subcontractors or subsidiaries, regardless of their place of establishment.
4. Technical services shall keep at the disposal of the designating type-approval authority the relevant documents concerning the assessment carried out by the type-approval authorities or the accreditation carried out by the national accreditation body of the subcontractor or the subsidiary and the tasks performed by them.
5. [...]

Article 76
In-house technical services of the manufacturer

1. An in-house technical service of a manufacturer may be designated as a technical service for category A activities as referred to in Article 72(1)(a) and only with regard to the regulatory acts listed in Annex XV. An in-house technical service shall constitute a separate and distinct part of the manufacturer's company and shall not be involved in the design, manufacturing, supply or maintenance of the vehicles, systems, components or separate technical units that it assesses.
2. An in-house technical service shall comply with the following requirements:
 - (a) it has been accredited by a national accreditation body as defined in point 11 of Article 2 of Regulation (EC) No 765/2008 and in accordance with Appendices 1 and 2 to Annex V to this Regulation;
 - (b) the in-house technical service, including its personnel, is organisationally identifiable and has reporting methods within the manufacturer's company of which they form part that ensures its impartiality and demonstrates that impartiality to the relevant type-approval authority and the national accreditation body;
 - (c) neither the in-house technical service nor its personnel is engaged in any activity that might conflict with its independence or its integrity to perform the activities for which it has been designated;
 - (d) it supplies its services exclusively to the manufacturer's company of which it forms part.
3. [...]

4. The Commission shall be empowered to adopt delegated acts in accordance with Article 88 to amend Annex XV to take account of technical and regulatory developments by updating the list of regulatory acts and restrictions contained therein.

Article 77

Assessment and designation of technical services

- 1. The applicant technical service shall submit a formal application to the type-approval authority of the Member State in which it requests to be designated according to part 4, Appendix 2 of Annex V. The application shall specify the activities for which the technical service is applying to be designated.
 1. Before a type-approval authority designates a technical service, the type-approval or the national accreditation body authority shall assess it in accordance with an assessment checklist that covers at least the requirements listed in Appendix 2 of Annex V. The assessment shall include an on-site assessment of the premises of the applying technical service, and, where relevant, of any subsidiary or sub-contractor, located inside or outside the Union.

[...]

- 1a. In cases where the assessment is carried out by a national accreditation body, the applicant technical service shall deliver to the type-approval authority a valid accreditation certificate and the corresponding assessment report attesting that the technical service fulfils the requirements set out in Appendix 2 of Annex V for the activities for which the applicant technical service is applying to be designated.
- 1b. In cases where the assessment is performed by the type-approval authority, the type-approval authority of the Member State in which the applicant technical service has requested to be designated shall formally appoint a joint assessment team composed of representatives of the type-approval authorities of at least two other Member States and a representative of the Commission.

Where the technical service applies to be designated in a Member State other than the Member State of its establishment, one of the representatives from type approval authority mentioned in first subparagraph shall be from the type-approval authority of the Member State of establishment, unless that type-approval authority decides against participating in the joint assessment.

The joint assessment team shall participate in the assessment of the applicant technical service, including the on-site assessment. The designating type-approval authority of the Member State in which the applicant technical service has requested to be designated shall give those representatives all necessary assistance and provide timely access to all documentation necessary to assess the applicant technical service.

- 1c. In cases where the assessment is performed by the type-approval authority of technical services which apply to perform tests exclusively for national individual vehicle approvals in accordance with Article 43, the type-approval authority of the Member State in which the applicant technical service has requested to be designated shall be exempt from the obligation to appoint a joint assessment team. The technical services which are only checking the correct installation of components on categories O₁ and O₂ shall also be exempted from joint assessment.
- 1d. If the technical service has requested to be designated by several type-approval authorities in accordance with Article 78(3), the assessment shall be carried out only once, provided that the entire scope of the technical service's designation has been covered in that assessment.
2. The joint assessment team shall raise findings regarding non-compliance of the applicant technical service with the requirements set out in Articles 72 to 76, in Articles 84 and 85 and in Appendix 2 to Annex V during the assessment process. These findings shall be discussed within the joint assessment team.

3. The joint assessment team shall produce after the on-site assessment a report setting out the extent to which the applicant complies with the requirements set out in in Articles 72 to 76, in Articles 84 and 85 and in Appendix 2 to Annex V of this Regulation.
4. This report shall contain a summary of any identified non-compliances, together with a recommendation whether the applicant could be designated as technical service.
5. The type-approval authority shall notify to the Commission the names and the expertise of their representatives to call upon for each joint assessment.
6. [...]
7. The type-approval authority shall send the report on the outcome of the assessment pursuant to the procedures set out in Appendix 2 of Annex V, to the Commission and, upon request, to the type-approval authorities of the other Member States, including documentary evidence regarding the competence of the technical service and the arrangements in place to regularly monitor the technical service.

[...]
8. The type-approval authorities of the other Member States and the Commission may review the assessment report and the documentary evidence, raise questions or concerns and request further documentary evidence within one month from the date of reception of the assessment report and the documentary evidence.
9. The type-approval authority of the Member State where the applicant technical service has requested to be designated shall respond to the questions, concerns and requests for further documentary evidence within four weeks following their receipt.

10. The type-approval authorities of the other Member States or the Commission may individually or jointly address recommendations to the type-approval authority of the Member State where the applicant technical service has requested to be designated within four weeks following the receipt of the response referred to in paragraph 9. That type-approval authority shall take account of the recommendations when it takes the decision on the designation of the technical service. Where that type-approval authority decides not to follow the recommendations addressed by the other Member States or the Commission, it shall give the reasons therefor within two weeks after taking its decision.
11. The validity of the designation of technical services shall be limited to five years.
12. The approval authority that intends to be designated as a technical service in accordance with Article 72(2) shall document compliance with the requirements of this Regulation through an assessment conducted by independent auditors. Those auditors may be from within the same organisation provided that they are managed autonomously from the personnel undertaking the assessed activity and shall comply with the requirements laid down in Appendix 2 of Annex V.

Article 78

Notification to the Commission concerning designation of technical services

1. The type-approval authorities shall notify to the Commission the name, the address, including the electronic address, the responsible persons and the category of activities of every technical service that they have designated. The notification shall clearly specify the scope of the designation, the conformity assessment activities and procedures, the type of products and the subjects listed in Annex IV for which the technical services have been designated, any subcontractors or subsidiaries of the technical services, and subsequent modifications to any of those details.

That notification shall be made prior to the conduct of any activity referred to in Article 72(1) by the designated technical services.

2. [...]
3. A technical service may be designated by the type-approval authority of a different Member State than in which it is established, provided that the entire scope of the designation by the type-approval authority is covered by accreditation, in accordance with Article 77(1a) or jointly assessed in accordance with Article 77(1b).
4. [...]
5. The Commission shall publish on its website, and update, a list with details of the designated technical services, their subcontractors and their subsidiaries that have been notified to it in accordance with this Article.

Article 79

Changes to and renewal of designations of technical services

1. Where the type-approval authority has ascertained or has been informed that a technical service no longer complies with the requirements laid down in this Regulation, that authority shall restrict, suspend or withdraw the designation, as appropriate, depending on the seriousness of the failure to comply with those requirements.

The type-approval authority shall immediately notify to the Commission and the other Member States any suspension, restriction or withdrawal of a designation.

The Commission shall update the information published referred to in Article 78(5) accordingly.

2. In the event of a restriction, suspension or withdrawal of the designation, or where the technical service has ceased its activity, the type-approval authority shall keep the files of that technical service available for the approval authorities or for the market surveillance authorities or transfer those files to another technical service chosen by the manufacturer in agreement with that technical service.
3. The type-approval authority shall assess within three months whether the non-compliance of the technical service has an impact on type-approval certificates issued on the basis of the inspection and test reports issued by the technical service subject of the change in notification and inform the other type-approval authorities and the Commission accordingly.

Within two months after having notified the changes to the notification, the type-approval authority shall submit a report on its findings regarding the non-compliance to the Commission and the other type-approval authorities. Where necessary to ensure the safety of vehicles, systems, components or separate technical units already placed on the market, the designating authority shall instruct the concerned approval authorities to suspend or withdraw within a reasonable period of time, any certificates which were unduly issued.

4. Where the designation of technical services has been suspended, restricted or withdrawn, the type-approval certificates which were issued on the basis of inspection and test reports issued by those technical services shall remain valid unless those type-approvals become invalid in accordance with Article 33(2e).

[...]

5. An extension of the scope of the technical service's designation that leads to the designation of an additional category referred to in Article 72(1) shall be assessed in accordance with the procedure set out in Article 77.

An extension of the scope of the technical service's designation for the acts listed in Annex IV only may be carried out in accordance with the provisions set out in Appendix 2 of Annex V and subject to the notification referred to in Article 78.

6. A designation as technical service shall only be renewed after the type-approval authority has verified whether the technical service continues to comply with the requirements of this Regulation. That assessment shall be carried out in accordance with the procedure set out in Article 77.

Article 80

Monitoring of technical services

1. The designating type-approval authority shall continuously monitor the technical services to ensure compliance with the requirements set out in Articles 72 to 76, in Articles 84 and 85 and in Appendix 2 to Annex V.

The first subparagraph shall not apply to any activities of technical services which are monitored by accreditation bodies in accordance with Article 71(1) to ensure compliance with the requirements set out in Articles 72 to 76, in Articles 84 and 85 and in Appendix 2 to Annex V.

Technical services shall, on request, supply all relevant information and documents, required to enable that designating type-approval authority or national accreditation body to verify compliance with those requirements.

Technical services shall, without delay, inform the designating type-approval authority of any changes, in particular regarding their personnel, facilities, subsidiaries or subcontractors, which may affect compliance with the requirements set out in Articles 72 to 76, in Articles 84 and 85 and in Appendix 2 to Annex V, or their ability to perform the conformity assessment tasks relating to the vehicles, systems, components and separate technical units for which they have been designated.

2. Technical services shall respond without delay to requests by a type-approval authority or by the Commission in relation to the conformity assessments they have carried out.
3. The designating type-approval authority shall ensure that the technical service carries out its obligation laid down in paragraph 2, unless there is a legitimate reason for not doing so.

When that type-approval authority acknowledges a legitimate reason, it shall inform the Commission thereof.

The Commission shall consult without delay the Member States. On the basis of that evaluation, the Commission shall decide by means of an implementing act whether the legitimate reason is considered justified or not. Those implementing acts shall be adopted in accordance with the examination procedure referred to in Article 87(2).

The technical service or the designating type-approval authority may request that any information transmitted to the authorities of another Member State or to the Commission shall be treated confidentially.

- 3a. At least every 30 months, the designating type-approval authority shall assess whether each technical service under its responsibility continues to satisfy the requirements set out in Articles 72 to 76, in Articles 84 and 85 and in Appendix 2 to Annex V. This assessment shall include an on-site visit to each technical service under its responsibility.

Within two months after finalising this assessment of the technical service, the Member States shall report to the Commission and to the other Member States on those monitoring activities. The reports shall contain a summary of the assessment which shall be made publicly available.

4. [...]

Article 81

Challenge to the competence of technical services

1. The Commission, in cooperation with the type-approval authority of the Member State concerned, shall investigate all cases where concerns have been brought to its attention regarding the competence of a technical service or the continued compliance by a technical service with the requirements and responsibilities to which it is subject under this Regulation. It may also commence such investigations on its own initiative.

The Commission shall investigate the responsibility of the technical service in the case where it is demonstrated or where there are justified grounds to consider that a type approval has been granted on the basis of false data or that the test results have been falsified or that data or technical specifications have been withheld that would have led to the refusal to grant the type approval.

2. The Commission shall consult the type-approval authority of the Member State which designated the technical service as part of the investigation referred to in paragraph 1. The type-approval authority of that Member State shall provide the Commission, upon request, with all relevant information relating to the performance and the compliance with the requirements concerning independence and competence of the technical service concerned.

3. The Commission shall ensure that all sensitive information obtained in the course of its investigations is treated confidentially.
4. Where the Commission ascertains that a technical service does not or no longer comply with the requirements for its designation or that it is responsible for any of the wrong-doings referred to in paragraph 1, it shall inform the Member State of the type-approval authority thereof.

The Commission shall request that Member State to take restrictive measures, including the suspension, restriction or withdrawal of the designation, where necessary.

Where the Member State fails to take the necessary restrictive measures, the Commission may, by means of implementing acts, suspend, restrict or withdraw the designation of the technical service concerned. Those implementing acts shall be adopted in accordance with the examination procedure referred to in Article 87(2). The Commission shall notify the Member State concerned of its decision and shall update the information published referred to in Article 78(5) accordingly.

Article 82

Exchange of information on assessment, designation and monitoring of technical services

1. Type-approval authorities shall consult each other and the Commission on questions with general relevance with regard to the implementation of the requirements set out in this Regulation in relation with the assessment, designation and monitoring of technical services.
2. Type-approval authorities shall communicate to each other and the Commission not later than two years after the entry into force of this Regulation the model for assessment check-list used in accordance with Article 77(1) and thereafter the adaptations made to this check-list until the Commission has adopted a harmonised assessment check-list. The Commission shall be empowered to adopt implementing acts to establish the template of the assessment check-list. Those implementing acts shall be adopted in accordance with the examination procedure referred to in Article 87(2).

3. When the assessment reports referred to in Article 77(3) indicate discrepancies in the general practice of type-approval authorities, Member States or the Commission may request an exchange of information.
4. The exchange of information shall be co-ordinated by the Forum established pursuant to Article 10.

Article 83

Cooperation with national accreditation bodies

1. Where designation of a technical service is based on accreditation within the meaning of Regulation (EC) No 765/2008, the national accreditation body and the type-approval authority shall maintain full cooperation and shall exchange relevant information in compliance with the obligations in Regulation (EC) No 765/2008, including incident reports and other information that relate to matters under the control of the technical service when that information is relevant for the assessment of the performance of the technical service.
2. Member States shall ensure that the national accreditation body in charge of the accreditation of a particular technical service is kept informed by the type-approval authority of the Member State where the technical service is established on findings relevant for the accreditation. The national accreditation body shall inform the type-approval authority of the Member State where the technical service is established on its findings.

Article 84
Operational obligations of technical services

1. Technical services shall carry out the activities for which they have been designated in accordance with Article 72(1).
2. Technical services shall comply at all times with all of the following:
 - (a) allow their type-approval authority to witness the performance of the technical service during testing for type-approval;
 - (b) provide their type-approval authority, upon request, with information on the categories of activities for which they have been designated.
3. Where a technical service finds that a manufacturer does not comply with the requirements laid down in this Regulation, it shall report this to the type-approval authority in order for the type-approval authority to require the manufacturer to take appropriate corrective measures. The type-approval authority shall refuse to issue a type-approval certificate where those appropriate corrective measures have not been taken.

Article 85
Information obligations of technical services

1. Technical services shall inform their type-approval authority of the following:
 - (a) any non-conformity encountered which may require a refusal, restriction, suspension or withdrawal of a type-approval certificate;
 - (b) any circumstances affecting the scope of and conditions for their designation;

- (c) any request for information which they have received from market surveillance authorities regarding their activities.
2. Upon request from their type-approval authority, technical services shall provide information on the activities within the scope of their designation and on any other activity performed, including cross-border activities and subcontracting.

Article 86
[...]

CHAPTER XVI

IMPLEMENTING AND DELEGATED POWERS

Article 87
Committee procedure

1. The Commission shall be assisted by the Technical Committee — Motor Vehicles. That committee shall be a committee within the meaning of Regulation (EU) No 182/2011.
2. Where reference is made to this paragraph, Article 5 of Regulation (EU) No 182/2011 shall apply.

Where the committee delivers no opinion, the Commission shall not adopt the draft implementing act and the third subparagraph of Article 5(4) of Regulation (EU) No 182/2011 shall apply.

Article 88
Exercise of the delegation

1. The power to adopt delegated acts is conferred on the Commission subject to the conditions laid down in this Article.
2. The power to adopt delegated acts referred to in Article 4(2), Article 5(2), Article 24(3), Article 28(5), Article 29(6), Article 39(4), Article 42(6), Article 55(2) and (3), Article 60(3), Article 65(10), Article 74(3), Article 76(4) and Article 90(2) shall be conferred on the Commission for a period of five years from the date of entry into force of this Regulation.

The Commission shall draw up a report in respect of the delegation of power not later than nine months before the end of the five-year period. The delegation of power shall be tacitly extended for periods of an identical duration, unless the European Parliament or the Council opposes such extension not later than three months before the end of each period.

3. The delegation of power referred to in Article 4(2), Article 5(2), Article 24(3), Article 28(5), Article 29(6), Article 39(4), Article 42(6), Article 55(2) and (3), Article 60(3), Article 65(10), Article 74(3), Article 76(4) and Article 90(2) may be revoked at any time by the European Parliament or by the Council. A decision to revoke shall put an end to the delegation of the power specified in that decision. It shall take effect the day following the publication of the decision in the *Official Journal of the European Union* or at a later date specified therein. It shall not affect the validity of any delegated acts already in force.
- 3a. Before adopting a delegated act, the Commission shall consult experts designated by each Member State in accordance with the principles laid down in the Interinstitutional Agreement on Better Law-Making of 13 April 2016.
4. As soon as it adopts a delegated act, the Commission shall notify it simultaneously to the European Parliament and to the Council.
5. A delegated act adopted pursuant to Article 4(2), Article 5(2), Article 24(3), Article 28(5), Article 29(6), Article 39(4), Article 42(6), Article 55(2) and (3), Article 60(3), Article 65(10), Article 74(3), Article 76(4) and Article 90(2) shall enter into force only if no objection has been expressed either by the European Parliament or the Council within a period of two months of notification of that act to the European Parliament and the Council or if, before the expiry of that period, the European Parliament and the Council have both informed the Commission that they will not object. That period shall be extended by two months at the initiative of the European Parliament or of the Council.

CHAPTER XVII FINAL PROVISIONS

Article 89 Penalties

1. Member States shall lay down the rules on penalties for infringement by economic operators and technical services of their obligations laid down in the Articles of this Regulation and shall take all measures necessary to ensure that they are implemented. The penalties provided for shall be effective, proportionate and dissuasive, in particular proportionate to the extent of non-compliance and the number of non-compliant vehicles, systems, components or separate technical units made available on the market of the Member State concerned.
2. The types of infringements by economic operators and technical services subject to penalties shall be at least the following:
 - (a) making false declarations during approval procedures or corrective or restrictive measures being imposed in accordance with Chapter XI;
 - (b) falsifying test results for type-approval or for market surveillance;
 - (c) withholding data or technical specifications that could lead to the recall of vehicles, systems, components and separate technical units, or to the refusal or withdrawal of type-approval certificate;
 - (d) non-compliance by technical services in respect of the requirements for their designation.

3. In addition to the types of infringements set out in paragraph 2, the types of infringements by economic operators that are also subject to penalties shall be at least the following:
 - (a) refusing to provide access to information;
 - (b) making available on the market vehicles, systems, components or separate technical units subject to approval without such approval or falsifying documents, certificates of conformity, statutory plates or approval marks with that intention.
4. Member States shall notify the provisions implementing paragraphs 1 to 3 to the Commission by 1 September 2020 and shall notify the Commission without delay of any subsequent amendment affecting those provisions.
5. Member States shall report to the Commission every year on the penalties they have imposed. In case no penalties were imposed in a given year Member States shall not report to the Commission.
6. The Commission shall elaborate a summary report on the penalties imposed by Member States. The report may include recommendations for Member States and it shall be submitted to the Forum established according to Article 10.

Article 90

Administrative fines in support of corrective and restrictive measures at EU level

1. When the Commission takes decisions in accordance with Article 50, it may impose administrative fines upon the concerned economic operators for non-compliance of the vehicle, system, component, separate technical unit with the requirements laid down in this Regulation. The administrative fines provided for shall be effective, proportionate and dissuasive. In particular the fines shall be proportionate to the number of non-compliant vehicles registered in the Union market, or the number of non-compliant systems, components or separate technical unit made available on the Union market.

The administrative fines imposed by the Commission shall not be in addition to the penalties imposed by the Member States in accordance with Article 89 for the same infringement. The administrative fines imposed by the Commission shall not exceed EUR 30 000 per non-compliant vehicle, system, component or separate technical unit.

The Commission may not bring, start afresh or continue proceedings under this Article against economic operators for infringements of this Regulation for which the concerned economic operators have been penalised or declared not liable in accordance with Article 89 by an earlier decision that can no longer be challenged.

2. The Commission shall adopt, on the basis of the principles set out in paragraph 2a, delegated acts to lay down the procedure, methods for the calculation and collection of the administrative fines referred to in paragraph 1.
- 2a. The delegated acts referred to in paragraph 2 shall respect the following principles:
 - (a) the procedure by the Commission shall respect the right to good administration, including in particular the right to be heard and the right to have access to the file, while respecting the legitimate interests of confidentiality and of professional and business secrecy;
 - (b) in calculating the appropriate administrative fine, the Commission shall be guided by the principles of effectiveness, proportionality and dissuasiveness, taking into consideration, where relevant, the seriousness and the effects of the infringement, the good faith of the economic operator, the degree of diligence and cooperation of the economic operator, the repetition, frequency or duration of the infringement as well as prior sanctions imposed on the same economic operator;

- (c) administrative fines shall be collected without undue delay by fixing deadlines for the payment and, as appropriate, including the possibility of splitting payments into several instalments and phases.
3. The amounts of administrative fines shall be considered as revenue for the general budget of the European Union.

Article 91
Amendments to Regulation (EC) No 715/2007

1. Regulation (EC) No 715/2007 is amended as follows:
- (1) The title of the Regulation is replaced by the following:
‘Regulation (EC) No 715/2007 of the European Parliament and of the Council of 20 June 2007 on type approval of motor vehicles with respect to emissions from light passenger and commercial vehicles (Euro 5 and Euro 6)’;
 - (2) in Article 1, paragraph 2 is replaced by the following:
‘2. In addition, this Regulation lays down rules for in-service conformity, durability of pollution control devices, vehicle OBD systems and measurement of fuel consumption.’;
 - (3) in Article 3, points 14 and 15 are deleted;
 - (4) Articles 6 to 9 are deleted;
 - (5) in Article 13(2), point (e) is deleted.
 - (6) [...]
2. References to the deleted provisions of Regulation (EC) No 715/2007 shall be construed as references to this Regulation and shall be read in accordance with the correlation table set out in point 1 of Annex XIX to this Regulation.

Article 92
Amendments to Regulation (EC) No 595/2009

1. Regulation (EC) No 595/2009 is amended as follows:
 - (0) The title of the Regulation is replaced by the following:

‘Regulation (EC) No 595/2009 of the European Parliament and of the Council of 18 June 2009 on type-approval of motor vehicles and engines with respect to emissions from heavy duty vehicles (Euro VI) and amending Regulation (EC) No 715/2007 and Directive 2007/46/EC and repealing Directives 80/1269/EEC, 2005/55/EC and 2005/78/EC’
 - (1) in Article 1, paragraph 2 is replaced by the following:

‘2. This Regulation also lays down rules for in-service conformity of vehicles and engines, durability of pollution control devices, vehicle OBD systems, measurement of fuel consumption and CO2 emissions and accessibility of vehicle OBD.’
 - (2) in Article 3, points 11 and 13 are deleted;
 - (3) Article 6 is deleted;
 - (4) in Article 11(2), point (e) is deleted.
2. References to the deleted provisions of Regulation (EC) No 595/2009 shall be construed as references to this Regulation and shall be read in accordance with the correlation table set out in point 2 of Annex XIX to this Regulation.

Article 93
[...]

Article 94
[...]

Article 95
Repeal of Directive 2007/46/EC

Directive 2007/46/EC is repealed with effect from 1 September 2020.

References to Directive 2007/46/EC shall be construed as references to this Regulation and shall be read in accordance with the correlation table set out in point 5 of Annex XVIII to this Regulation.

Article 96
Transitional provisions

1. This Regulation shall not invalidate any whole-vehicle type-approval or EU type-approval granted to vehicles or to systems, components or separate technical units before 1 September 2020.
2. Approval authorities shall grant extensions and revisions of whole-vehicle type-approvals and EU type-approvals to the vehicles, systems, components or separate technical units referred to in paragraph 1 in accordance with Articles 31 and 32 of this Regulation.
3. [...]
4. Technical services already designated before the entry into force of this Regulation shall be subject to the assessment referred to in Article 77.

The designation of technical services already designated before the entry into force of this Regulation shall be renewed within four years of the entry into force of this Regulation where those technical services comply with the relevant requirements set out in this Regulation.

The validity of the designation of technical services made before the entry into force of this Regulation shall terminate at the latest four years after the date of entry into force of this Regulation.

Article 97
Reporting

1. By 1 September 2025 Member States shall inform the Commission of the application of the type-approval and market surveillance procedures laid down in this Regulation.
2. On the basis of the information supplied under paragraph 1, the Commission shall present an evaluation report to the European Parliament and the Council on the application of this Regulation, including on the functioning of the compliance verification in accordance with Article 9 by 1 September 2026.

Article 98
Entry into force and application

This Regulation shall enter into force on the twentieth day following that of its publication in the *Official Journal of the European Union*.

It shall apply from 1 September 2020.

However, from [...] [*PO: please insert the date [...] 24 months after entry into force of this Regulation.*], national authorities shall not refuse to grant EU type-approval or national type-approval for a new type of vehicle, or prohibit registration, placing on the market or entry into service of a new vehicle where the vehicle concerned complies with this Regulation, if a manufacturer so requests.

This Regulation shall be binding in its entirety and directly applicable in all Member States.

Done at Brussels,

For the European Parliament

For the Council

The President

The President



List of Annexes

Annex I	[...]
Annex II	General definitions, criteria for vehicle categorisation, types of vehicle and types of bodywork
Appendix 1:	Procedure for checking whether a vehicle can be categorised as off-road vehicle
Appendix 2:	Digits used to supplement the codes to be used for various kinds of bodywork
Annex III	[...]
Annex IV	Requirements for the purpose of EU approval of vehicles, systems, components or separate technical units
Part I	Regulatory acts for EU type-approval of vehicles produced in unlimited series
Appendix 1:	Regulatory acts for EU type-approval of vehicles produced in small series pursuant to Article 39
Appendix 2:	Requirements for EU individual vehicle approval pursuant to Article 42
Part II	List of UNECE regulations recognised as an alternative to the Directives or Regulations referred to in Part I
Part III	List of regulatory acts setting out the requirements for the purpose of EU type-approval of special purpose vehicles
Appendix 1:	Motor-caravans, ambulances and hearses
Appendix 2:	Armoured vehicles
Appendix 3:	Wheelchair accessible vehicles
Appendix 4:	Other special purpose vehicles (including special group, multi-equipment carrier and trailer caravans)
Appendix 5:	Mobile cranes
Appendix 6:	Exceptional load transport trailers
Annex V	Procedures to be followed with respect to EU type-approval
Appendix 1:	Standards with which the entities referred to in Article 72 have to comply
Appendix 2:	Procedure for the assessment of the technical services
Appendix 3:	[...]
Annex VI	[...]

Appendix:	[...]
Annex VII	[...]
Appendix:	[...]
Annex VIII	[...]
Annex IX	[...]
Annex X	Conformity of production procedures
Annex XI	[...]
Appendix:	[...]
Annex XII	Small series and end-of-series limits
Annex XIII	List of parts or equipment that can pose a significant risk to the correct functioning of systems that are essential for the safety of the vehicle or its environmental performance, their performance requirements of such parts and equipment, the appropriate test procedures and marking and packaging provisions
Annex XIV	[...] ^s
Annex XV	Regulatory acts for which a manufacturer may be designated as a technical service
Appendix:	Designation of a manufacturer as technical service and subcontracting
Annex XVI	Conditions for the use of virtual testing methods by a manufacturer or a technical service
Appendix 1:	General conditions for the use of virtual testing methods
Appendix 2:	Specific conditions for the use of virtual testing methods
Appendix 3:	Validation process
Annex XVII	Procedures to be followed during EU multi-stage type-approval
Appendix:	Model of the manufacturer's additional plate
Annex XVIII	Access to vehicle OBD and vehicle repair and maintenance information
Appendix 1:	Manufacturer's certificate on access to vehicle OBD and vehicle repair and maintenance information
Appendix 2:	Vehicle OBD information
Annex XIX	Correlation table



[...]

GENERAL DEFINITIONS, CRITERIA FOR VEHICLE CATEGORISATION, TYPE OF VEHICLE AND TYPES OF BODYWORK

INTRODUCTORY PART

Definitions and general provisions

1. Definitions

1.1. ‘*Seating position*’ means any location capable of accommodating one person seated who is at least as large as:

(a) the manikin of the 50th percentile adult male in the case of the driver;

(b) the manikin of the 5th percentile adult female in all other cases.

1.2. ‘*Seat*’ means a complete structure with trim, integral or not with the vehicle body structure, which is intended to seat one person.

It includes both an individual seat and a bench seat, as well as folding seats and removable seats.

1.3. ‘*Goods*’ means primarily any movable things.

It includes products in bulk, manufactured goods, liquids, living animals, crops, indivisible loads.

1.4. ‘*Maximum mass*’ means the ‘technically permissible maximum laden mass’ as specified in point 2.8 of Annex I.

2. General provisions

2.1. Number of seating positions

2.1.1. The requirements regarding the number of seating positions apply to seats that are designed for use when the vehicle is travelling on the road.

2.1.2. They do not apply to seats that are designed for use when the vehicle is stationary and which are clearly identified to users either by means of a pictogram or a sign with an appropriate text.

2.1.3. The following requirements apply for the counting of the seating positions:

- (a) each individual seat shall be counted as one seating position;
- (b) in the case of a bench seat, any space having a width of at least 400 mm measured at the seat cushion level shall be counted as one seating position.

This condition shall not prevent the manufacturer from using the general provisions referred to in point 1.1;

- (c) however, a space as referred to in point (b) shall not be counted as one seating position where:
 - (i) the bench seat includes features that prevent the bottom of the manikin from sitting in a natural way - for example: the presence of a fixed console box, an unpadded area or an interior trim interrupting the nominal seating surface;
 - (ii) the design of the floor pan located immediately in front of a presumed seating position (for example the presence of a tunnel) prevents the feet of the manikin from being positioned in a natural way.

2.1.4. With respect to vehicles covered by UNECE Regulations No 66 and No 107, the dimension referred to in point 2.1.3(b) shall be aligned with the minimum space required for one person in relation to the various classes of vehicles.

- 2.1.5. When seat anchors for a removable seat are present in a vehicle, the removable seat shall be counted in the determination of the number of the seating positions.
- 2.1.6. An area intended for an occupied wheelchair shall be regarded as one seating position.
- 2.1.6.1. This provision shall be without prejudice to the requirements of paragraphs 3.6.1 and 3.7 of Annex 8 to UNECE Regulation No 107.
- 2.2. Maximum mass
- 2.2.1. In the case of a tractor unit for semi-trailer, the maximum mass to be considered for classifying the vehicle shall include the maximum mass of the semi-trailer borne by the fifth wheel coupling.
- 2.2.2. In the case of a motor vehicle that can tow a centre-axle trailer or a rigid drawbar trailer, the maximum mass to be considered for classifying the motor vehicle shall include the maximum mass transferred to the towing vehicle by the coupling.
- 2.2.3. In the case of a semi-trailer, a centre-axle trailer and a rigid drawbar trailer, the maximum mass to be considered for classifying the vehicle shall correspond to the maximum mass transmitted to the ground by the wheels of an axle or group of axles when coupled to the towing vehicle.
- 2.2.4. In the case of a converter dolly, the maximum mass to be considered for classifying the vehicle shall include the maximum mass of the semi-trailer borne by the fifth wheel coupling.

2.3. Special equipment

- 2.3.1. Vehicles fitted primarily with fixed equipment such as machinery or apparatus shall be regarded as N or O category.

2.4. Units

- 2.4.1. Unless otherwise stated any unit of measurement and associated symbol shall conform to the provisions of Council Directive 80/181/EEC¹⁸.

3. Categorisation into vehicle categories

- 3.1. The manufacturer is responsible for the categorisation of a type of vehicle into a specific category.

For such purposes, all the relevant criteria described in this Annex shall be met.

- 3.2. The approval authority may request from the manufacturer appropriate additional information with the aim of demonstrating that a type of vehicle needs to be categorised as special purpose vehicle in the special group ('SG Code').

¹⁸ Council Directive 80/181/EEC of 20 December 1979 on the approximation of the laws of the Member States relating to units of measurement and on the repeal of Directive 71/354/EEC (OJ L 39, 15.2.1980, p. 40).

PART A

Criteria for vehicle categorisation

1. Vehicle categories

For the purposes of EU and national type-approval, as well as for EU and national individual vehicle approval, vehicles shall be categorised according to the classification referred to in Article 4.

Approval can only be granted for the categories referred to in Article 4(1).

2. Vehicle subcategories

2.1. Off-road vehicles

‘*Off-road vehicle (ORV)*’ means a vehicle that belongs to category M or N, having specific technical features which permit its use off the normal roads.

For those categories of vehicles, the letter ‘G’ shall be added as suffix to the letter and numeral identifying the vehicle category.

The criteria for the subcategorisation of vehicles as ‘ORV’ shall be specified in section 4 of Part A.

2.2. Special purpose vehicles (SPV)

2.2.1. For incomplete vehicles that are intended to fall into the SPV subcategory, the letter ‘S’ shall be added as suffix to the letter and numeral identifying the vehicle category.

The various types of special purpose vehicles are defined and listed in section 5.

2.3. Off road special purpose vehicle

2.3.1. ‘*Off road special purpose vehicle (ORV-SPV)*’ means a vehicle that belongs either to category M or N having the specific technical features referred to in points 2.1 and 2.2. For those categories of vehicles, the letter ‘G’ shall be added as suffix to the letter and numeral identifying the vehicle category.

Moreover, for incomplete vehicles that are intended to fall into the SPV subcategory, the letter ‘S’ shall be added as second suffix.

3. Criteria for the categorisation of vehicles in category N

3.1. The categorisation of a type of vehicle in category N shall be based on the technical features of the vehicle as referred to in points 3.2 to 3.6.

3.2. As a matter of principle, the compartment(s) where all the seating positions are located, shall be completely separated from the loading area.

3.3. By way of derogation from the requirements of point 3.2, persons and goods may be transported in the same compartment under the condition that the loading area is provided with securing devices designed to protect persons transported against the displacement of the load during driving, including severe braking and cornering.

3.4. Securing devices - lashing devices - intended for securing the load as required in point 3.3 as well as partitioning systems, intended for vehicles up to 7,5 tonnes shall be designed in accordance with the provisions of sections 3 and 4 of Standard ISO 27956:2009 ‘Road vehicles – Securing of cargo in delivery vans – Requirements and test methods’.

3.4.1. The requirements referred to in point 3.4 may be verified by a statement of compliance provided by the manufacturer.

3.4.2. As an alternative to the requirements of point 3.4, the manufacturer may demonstrate to the satisfaction of the approval authority that the securing devices fitted show an equivalent level of protection as provided in the referred standard.

3.5. The number of seating positions excluding the driver's seating position shall not exceed:

(a) 6 in the case of N_1 vehicles;

(b) 8 in the case of N_2 or N_3 vehicles.

3.6. Vehicles shall show a goods-carrying capacity equal or higher than the person-carrying capacity expressed in kg.

3.6.1. For such purposes, the following equations shall be satisfied in all configurations, in particular when all seating positions are occupied:

(a) when $N = 0$:

$$P - M \geq 100 \text{ kg}$$

(b) when $0 < N \leq 2$:

$$P - (M + N \times 68) \geq 150 \text{ kg};$$

(c) when $N > 2$:

$$P - (M + N \times 68) \geq N \times 68;$$

where the letters have the following meaning:

'P' is the technically permissible maximum laden mass;

'M' is the mass in running order;

'N' is the number of seating positions excluding the driver's seating position.

- 3.6.2. The mass of equipment that is fitted to the vehicle in order to accommodate goods (e.g. tank, bodywork, etc.), to handle goods (e.g. crane, lift, etc.) and to secure goods (e.g. cargo securing devices) shall be included in M.
- 3.6.3. The mass of equipment that is not used for the purposes referred to in point 3.6.2 (such as a compressor, a winch, an electric power generator, broadcasting equipment, etc.) shall not be included in M for the purposes of the application of the formulae referred to in point 3.6.1.
- 3.7. The requirements referred to in points 3.2 to 3.6 shall be met for all variants and versions within the type of vehicle.
- 3.8. Criteria for the categorisation of vehicles as N₁.
- 3.8.1. A vehicle shall be categorised as N₁ when all the applicable criteria are met.
When one or more of the criteria are not met, the vehicle shall be categorised as M₁.
- 3.8.2. In addition to the general criteria referred to in points 3.2 to 3.6, the criteria specified in points 3.8.2.1 to 3.8.2.3.5 shall be met for the categorisation of vehicles for which the compartment where the driver is located and the load are within a single unit (i.e. bodywork 'BB').
- 3.8.2.1. The fact that a wall or a partition, complete or partial, is fitted between a seat row and the cargo area shall not rule out the obligation to meet the required criteria.

3.8.2.2. The criteria shall be as follows:

- (a) the loading of the goods shall be possible by a rear door, a tailgate or a side-door designed and constructed for that purposes;
- (b) in the case of a rear door or a tailgate, the loading aperture shall meet the following requirements:
 - (i) in the case the vehicle is fitted with only one row of seats or with only the driver seat, the minimum height of the loading aperture shall be at least 600 mm;
 - (ii) in the case the vehicle is fitted with two or more rows of seats, the minimum height of the loading aperture shall be at least 800 mm and the aperture shall show a surface of at least 12 800 cm²;
- (c) The cargo area shall meet the following requirements:

'cargo area' means the part of the vehicle located behind the row(s) of seats or behind the driver seat when the vehicle is fitted with only one driver seat;

- (i) the loading surface of the cargo area shall be generally flat;
- (ii) where the vehicle is fitted with only one row of seats or with one seat, the minimum length of the cargo area shall be at least 40 % of the wheelbase;
- (iii) where the vehicle is fitted with two or more rows of seats, the minimum length of the cargo area shall be at least 30 % of the wheelbase.

Where the seats of the last row of seats can be easily removed from the vehicle without the use of special tools, the requirements regarding the length of the cargo area shall be met with all the seats installed in the vehicle;

- (iv) the requirements regarding the length of the cargo area shall be met when the seats of the first row or of the last row, as the case may be, are upright in their normal position for use by the vehicle occupants.

3.8.2.3. Specific conditions for measurement

3.8.2.3.1. Definitions

- (a) '*Height of the loading aperture*', means the vertical distance between two horizontal planes tangent respectively to the highest point of the lower part of the doorway and the lowest point of the upper part of the doorway;
- (b) '*Surface of the loading aperture*' means the greatest surface of the orthogonal projection on a vertical plane, perpendicular to the centreline of the vehicle, of the maximum aperture permitted when the rear door(s) or tailgate is (are) wide open;
- (c) '*Wheelbase*', for the purposes of application of the formulae in points 3.8.2.2 and 3.8.3.1, means the distance between:
 - (i) the centreline of the front axle and the centreline of the second axle in the case of a two axle vehicle; or
 - (ii) the centreline of the front axle and the centreline of a virtual axle equally distant from the second and third axle in the case of a three axle vehicle.

3.8.2.3.2. Seat adjustments

- (a) The seats shall be adjusted at their rear outermost positions;
- (b) The seat back, if adjustable, shall be adjusted as to accommodate the three-dimensional H-point machine at a torso angle of 25 degrees;
- (c) The seat back, if not adjustable, shall be in the position designed by the vehicle manufacturer;
- (d) When the seat is adjustable in height, it shall be adjusted to its lowest position.

3.8.2.3.3. Vehicle conditions

- (a) The vehicle shall be in loaded conditions corresponding to its maximum mass;
- (b) The vehicle shall be with its wheels straight ahead.

3.8.2.3.4. The requirements of point 3.8.2.3.2 shall not apply when the vehicle is fitted with a wall or a partition.

3.8.2.3.5. Measurement of the length of the cargo area

- (a) When the vehicle is not fitted with a partition or a wall, the length shall be measured from a vertical plane tangent to the rear outermost point of the top of the seat back to the rear internal pane or door or tailgate, in closed position;
- (b) When the vehicle is fitted with a partition or a wall, the length shall be measured from a vertical plane tangent to the rear outermost point of the partition or the wall to the rear internal pane or door or tailgate, as the case may be, in closed position;
- (c) The requirements concerning the length shall be fulfilled at least along a horizontal line situated in the longitudinal vertical plane passing through the centreline of the vehicle, at the level of the load floor.

3.8.3. In addition to the general criteria referred to in points 3.2 to 3.6, the criteria specified in points 3.8.3.1 to 3.8.3.4 shall be met for the categorisation of vehicles for which the compartment where the driver is located and the load are not within a single unit (i.e. bodywork 'BE').

- 3.8.3.1. Where the vehicle is fitted with an enclosure type body, the following shall apply:
- (a) the loading of the goods shall be possible by a rear door, a tailgate or a panel or other means;
 - (b) the minimum height of the loading aperture shall be at least 800 mm and the aperture shall show a surface of at least 12 800 cm²;
 - (c) The minimum length of the cargo area shall be at least 40 % of the wheelbase.
- 3.8.3.2. Where the vehicle is fitted with an open type cargo area, only the provisions referred to in points 3.8.3.1(a) and (c) shall apply.
- 3.8.3.3. For the application of the provisions referred to in point 3.8.3, the definitions in point 3.8.2.3.1 shall apply.
- 3.8.3.4. However, the requirements concerning the length of the cargo area shall be fulfilled along a horizontal line situated in the longitudinal plane passing through the centreline of the vehicle at the level of the load floor.

4. Criteria for the sub-categorisation of vehicles as off-road vehicles

4.1. M₁ or N₁ vehicles shall be subcategorised as off-road vehicles if they satisfy at the same time the following conditions:

- (a) at least one front and at least one rear axle designed to be driven simultaneously irrespective of whether one powered axle can be disengaged;
- (b) at least one differential locking mechanism or a mechanism having similar effect is fitted;
- (c) they are able to climb at least a 25 % gradient as solo vehicle;
- (d) they satisfy five out of the following six requirements:
 - (i) the approach angle shall be at least 25 degrees;
 - (ii) the departure angle shall be at least 20 degrees;
 - (iii) the ramp angle shall be at least 20 degrees;
 - (iv) the ground clearance under the front axle shall be at least 180 mm;
 - (v) the ground clearance under the rear axle shall be at least 180 mm;
 - (vi) the ground clearance between the axles shall be at least 200 mm.

4.2. M₂, N₂ or M₃ vehicles the maximum mass of which does not exceed 12 tonnes shall be subcategorised as off-road vehicles if they satisfy the condition set out in point (a) or both conditions set out in points (b) and (c):

- (a) all their axles are driven simultaneously, irrespective of whether one or more powered axles can be disengaged;
- (b)
 - (i) at least one front and at least one rear axle are designed to be driven simultaneously irrespective of whether one powered axle can be disengaged;
 - (ii) at least one differential locking mechanism or a mechanism having the same effect is fitted;
 - (iii) they are able to climb a 25 % gradient as a solo vehicle;
- (c) they satisfy at least five out of the following six requirements if their maximum mass does not exceed 7,5 tonnes and at least four if their maximum mass exceeds 7,5 tonnes:
 - (i) the approach angle shall be at least 25 degrees;
 - (ii) the departure angle shall be at least 25 degrees;
 - (iii) the ramp angle shall be at least 25 degrees;
 - (iv) the ground clearance under the front axle shall be at least 250 mm;
 - (v) the ground clearance between axles shall be at least 300 mm;
 - (vi) the ground clearance under the rear axle shall be at least 250 mm.

4.3.M₃ or N₃ vehicles whose maximum mass exceeds 12 tonnes shall be subcategorised as off-road vehicles if they satisfy the condition set out in point (a) or both conditions set out in points (b) and (c):

- (a) all their axles are driven simultaneously, irrespective of whether one or more powered axles can be disengaged;
- (b)
 - (i) at least half of the axles (or two axles out of the three in the case of a three axle vehicle and three axles in the case of a five axle vehicle) is designed to be driven simultaneously, irrespective of whether one powered axle can be disengaged;
 - (ii) there is at least one differential locking mechanism or a mechanism having similar effect;
 - (iii) they are able to climb a 25 % gradient as solo vehicle;
- (c) they satisfy at least four out of the following six requirements:
 - (i) the approach angle shall be at least 25 degrees;
 - (ii) the departure angle shall be at least 25 degrees;
 - (iii) the ramp angle shall be at least 25 degrees;
 - (iv) the ground clearance under the front axle shall be at least 250 mm;
 - (v) the ground clearance between axles shall be at least 300 mm;
 - (vi) the ground clearance under the rear axle shall be at least 250 mm.

4.4. The procedure for checking compliance with the geometrical provisions referred to in this section shall be set out in Appendix 1.44

4.5. The requirement in Points 4.1(a), 4.2(a), 4.2(b), 4.3(a), 4.3(b) above on simultaneous driven axles are considered as fulfilled if one of the following condition is fulfilled:

- (a) the transmission of the tractive power to all axles is performed by mechanical means only which provides traction in heavy off-road, or
- (b) each of the wheels of the axle in question is driven by an individual hydraulic or electric engine.

If the axles according the requirements in Points 4.1(a), 4.2(a), 4.2(b), 4.3(a), 4.3(b) above on simultaneous driven axles are not powered by mechanical means only, the propulsion of the individual wheels shall be designed for heavy off-road operation. In such case it shall be ensured that at least 75 % of total tractive power can be transmit to the wheel in question when the tractive conditions under the rest wheels do not allow to transmit the tractive power properly via these wheels.

The auxiliary drive system according Point 4.5(b) shall not allow to disengaged the tractive power automatically until the vehicle reaches 75 % of maximum vehicle design speed or reaches 65 km/h.

5. Special purpose vehicles

	Name	Code	Definition
5.1.	Motor caravan	SA	<p>A vehicle of category M with living accommodation space which contains the following equipment as a minimum:</p> <ul style="list-style-type: none"> (a) seats and table; (b) sleeping accommodation which may be converted from the seats; (c) cooking facilities; (d) storage facilities. <p>This equipment shall be rigidly fixed to the living compartment.</p> <p>However, the table may be designed to be easily removable.</p>
5.2.	Armoured vehicle	SB	A vehicle intended for the protection of conveyed persons or goods with anti-bullet armour plating.
5.3.	Ambulance	SC	A vehicle of category M intended for the transport of sick or injured persons and having special equipment for such purpose.
5.4.	Hearse	SD	A vehicle of category M intended for the transport of deceased persons and having special equipment for such purpose.

5.5.	Wheelchair accessible vehicle	SH	A vehicle of category M ₁ constructed or converted specifically so that they accommodate one or more persons seated in their wheelchairs when travelling on the road.
5.6.	Trailer caravan	SE	A vehicle of category O as defined in term 3.2.1.3 of Standard ISO 3833:1977.
5.7.	Mobile crane	SF	A vehicle of category N ₃ , not fitted for the carriage of goods, provided with a crane whose lifting moment is equal to or higher than 400 kNm.
5.8.	Special group	SG	A special purpose vehicle that does not enter in any of the definitions mentioned in this section.
5.9.	Converter dolly	SJ	A vehicle of category O equipped with a fifth-wheel coupling to support a semi-trailer with a view to converting the latter into a trailer.
5.10.	Exceptional load transport trailer	SK	A vehicle of category O ₄ intended for the transport of indivisible loads that is subject to speed and traffic restrictions because of its dimensions. Under this term are also included hydraulic modular trailers irrespective of the number of modules.

5.11.	Exceptional load transport motor vehicle	SL	<p>A road tractor or tractor unit for semi-trailer of category N3 meeting all the following conditions:</p> <ul style="list-style-type: none"> (a) having more than two axles and at least half of the axles (two axles out of three in the case of a three axle vehicle and three axles out of five in the case of a five axle vehicle) designed to be driven simultaneously, irrespective of whether one powered axle can be disengaged, (b) that is designed for towing and pushing exceptional load transport trailer of category O4, (c) that has a minimum engine power of 350 kW, and (d) that can be equipped with an additional front coupling device for heavy towable masses
-------	--	----	---

5.12.	Multi-equipment carrier	SM	<p>An off-road vehicle of category N (as defined in point 2.3) designed and constructed for pulling, pushing, carrying and actuating certain inter-changeable equipment,</p> <p>(a) with not less than two mounting areas for this equipment,</p> <p>(b) with standardised, mechanical, hydraulic and/or electrical interfaces (e.g. Power take off) for powering and actuating the inter-changeable equipment and</p> <p>(c) that fulfils the definition of ISO 3833-1977, paragraph 3.1.4 (special vehicle).</p> <p>If the vehicle is equipped with an auxiliary load platform, its maximum length shall not exceed:</p> <p>(a) 1,4 times of the front or rear track width of the vehicle, whichever is the larger in the case of two axle vehicles, or</p> <p>(b) 2,0 times of the front or rear track width of the vehicle, whichever is the larger in the case of vehicles having more than two axles</p>
-------	-------------------------	----	--

6. Remarks

6.1. Type-approval shall not be granted:

- (a) to converter dolly as defined in section 5 of Part A;
- (b) to rigid drawbar trailers as defined in section 4 of Part C;
- (c) to trailers in which persons may be carried when travelling on the road.

6.2. Point 6.1 is without prejudice to the provisions of Article 40 on national small series type-approval.

PART B

Criteria for types of vehicle, variants and versions

1. Category M₁

1.1. Type of vehicle

1.1.1. A 'type of vehicle' shall consist of vehicles that have the following features in common:

- (a) the manufacturer's company name.

A change in the legal form of ownership of the company does not require that a new approval has to be granted;

- (b) the design and assembly of the essential parts of the body structure in the case of a self-supporting body.

The same shall apply to vehicles the bodywork of which is bolted on or welded to a separate frame;

1.1.2. By way of derogation from the requirements of point 1.1.1(b), when the manufacturer uses the floor portion of the body structure as well as the essential constituent elements forming the front part of the body structure located directly in front of the windscreen bay, in the construction of different kinds of bodywork (for example a saloon and a coupe), those vehicles may be considered as belonging to the same type. Evidence thereof shall be provided by the manufacturer.

1.1.3. A type shall consist of at least one variant and one version.

1.2. Variant

1.2.1. A 'variant' within a type of vehicle shall group the vehicles that have the following construction features in common:

- (a) the number of lateral doors or the type of bodywork as defined in section 2 of Part C when the manufacturer uses the criterion of point 1.1.2;
- (b) the power plant with regard to the following construction features:
 - (i) the type of energy supply (internal combustion engine, electric motor or other);
 - (ii) the working principle (positive ignition, compression ignition or other);
 - (iii) the number and arrangement of cylinders in the case of internal combustion engine (L4, V6 or other);
- (c) the number of axles;
- (d) the number, and interconnection of powered axles;
- (e) the number of steered axles;
- (f) the stage of completion (e.g. complete/incomplete).
- (g) in the case of multi-stage built vehicles, the manufacturer and the type of the previous stage vehicle.

1.3. Version

1.3.1. A 'version' within a variant shall group the vehicles that have the following features in common:

- (a) the technically permissible maximum laden mass;
- (b) the engine capacity in the case of internal combustion engine;
- (c) the maximum engine power output or the maximum continuous rated power (electric motor);
- (d) the nature of the fuel (petrol, gas oil, LPG, bi-fuel or other);
- (e) the maximum number of seating positions;
- (f) drive-by sound level;
- (g) exhaust emission level (for example Euro 5, Euro 6 or other);
- (h) combined or weighted, combined CO₂ emissions;
- (i) electric energy consumption (weighted, combined);
- (j) combined or weighted, combined fuel consumption;

As an alternative to the criteria (h), (i) and (j), the vehicles grouped into a version shall have all tests performed for the calculation of their CO₂ emissions, electric energy consumption and fuel consumptions according to the provisions of sub-Annex 6 to Annex XXI of Regulation (EU) 2017/1151 in common.

2. Categories M₂ and M₃

2.1. Type of vehicle

2.1.1. A 'type of vehicle' shall consist of vehicles that have the following features in common:

(a) the manufacturer's company name.

A change in the legal form of ownership of the company does not require that a new approval has to be granted;

(b) the category;

(c) the following aspects of construction and design:

(i) the design and construction of the essential constituent elements forming the chassis;

(ii) the design and construction of the essential constituent elements forming the body structure in the case of a self-supporting body;

(d) the number of decks (single or double);

(e) the number of sections (rigid/articulated);

(f) the number of axles;

(g) the mode of energy supply (on-board or off-board);

2.1.2. A type shall consist of at least one variant and one version.

2.2. Variant

2.2.1. A 'variant' within a type of vehicle shall group the vehicles that have all of the following construction features in common:

- (a) the type of bodywork as defined in section 3 of Part C;
- (b) the class or combination of classes of vehicles as defined in paragraph 2.1.1 of UNECE Regulation No 107 (only in the case of complete and completed vehicles);
- (c) the stage of completion (e.g. complete/incomplete/completed);
- (d) the power plant with regard to the following construction features:
 - (i) the type of energy supply (internal combustion engine, electric motor or other);
 - (ii) the working principle (positive ignition, compression ignition or other);
 - (iii) the number and arrangement of cylinders in the case of internal combustion engine (L6, V8 or other).
- (e) in the case of multi-stage built vehicles, the manufacturer and the type of the previous stage vehicle.

2.3. Version

2.3.1. A 'version' within a variant shall group the vehicles that have all the following features in common:

- (a) the technically permissible maximum laden mass;
- (b) the ability of the vehicle to tow a trailer or not;
- (c) the engine capacity in the case of internal combustion engine;
- (d) the maximum engine power output or the maximum continuous rated power (electric motor);
- (e) the nature of the fuel (petrol, gas oil, LPG, bi-fuel or other);
- (f) drive-by sound level;
- (g) exhaust emission level (for example Euro IV, Euro V or other).

3. Category N₁

3.1. Type of vehicle

3.1.1. A 'type of vehicle' shall consist of vehicles that have the following features in common:

(a) the manufacturer's company name.

A change in the legal form of ownership of the company does not require that a new approval has to be granted;

(b) the design and assembly of the essential parts of the body structure in the case of a self-supporting body;

(c) the design and the construction of the essential constituent elements forming the chassis in the case of a non-self-supporting body;

3.1.2. By way of derogation from the requirements of point 3.1.1(b), when the manufacturer uses the floor portion of the body structure as well the essential constituent elements forming the front part of the body structure located directly in front of the windscreen bay, in the construction of different kinds of bodywork (for example a van and a chassis-cab, different wheelbases and different roof heights), those vehicles may be considered as belonging to the same type. Evidence thereof shall be provided by the manufacturer.

3.1.3. A type of vehicle shall consist of at least one variant and one version.

3.2. Variant

3.2.1. A 'variant' within a type of vehicle shall group the vehicles that have the following construction features in common:

- (a) the number of lateral doors or the type of bodywork as defined in section 4 of Part C (for complete and completed vehicles) when the manufacturer uses the criterion of point 3.1.2;
- (b) the stage of completion (e.g. complete/incomplete/completed);
- (c) the power plant with regard to the following construction features:
 - (i) the type of energy supply (internal combustion engine, electric motor or other);
 - (ii) the working principle (positive ignition, compression ignition or other);
 - (iii) the number and arrangement of cylinders in the case of internal combustion engine (L6, V8 or other);
- (d) the number of axles;
- (e) the number and interconnection of powered axles;
- (f) the number of steered axles.
- (g) in the case of multi-stage built vehicles, the manufacturer and the type of the previous stage vehicle.

3.3. Version

3.3.1. A 'version' within a variant shall group the vehicles that have the following features in common:

- (a) the technically permissible maximum laden mass;
- (b) the engine capacity in the case of internal combustion engine;
- (c) the maximum engine power output or maximum continuous rated power (electric motor);
- (d) the nature of the fuel (petrol, gas oil, LPG, bi-fuel or other);
- (e) the maximum number of seating positions;
- (f) drive-by sound level;
- (g) exhaust emission level (for example Euro 5, Euro 6 or other);
- (h) combined or weighted, combined CO₂ emissions;
- (i) electric energy consumption (weighted, combined);
- (j) combined or weighted, combined fuel consumption.
- (k)** the existence of a unique set of innovative technologies, as specified in Article 12 of Regulation (EU) No 510/2011¹⁹)

As an alternative to the criteria (h), (i) and (j), the vehicles grouped into a version shall have all tests performed for the calculation of their CO₂ emissions, electric energy consumption and fuel consumptions according to the provisions of sub-Annex 6 to Annex XXI of Regulation (EU) 2017/1151 in common.

¹⁹ OJ L 145 31.5.2011, p. 1.

4. Categories N₂ and N₃

4.1. Type of vehicle

4.1.1. A 'type of vehicle' shall consist of vehicles that have the following features in common:

(a) the manufacturer's company name.

A change in the legal form of ownership of the company does not require that a new approval has to be granted;

(b) the category;

(c) the design and construction of the chassis that are common to a single line of product;

(d) the number of axles;

4.1.2. A type of vehicle shall consist of at least one variant and one version.

4.2. Variant

4.2.1. A 'variant' within a type of vehicle shall group the vehicles that have the following construction features in common:

- (a) the body structural concept or type of bodywork as defined in section 4 of Part C and in Appendix 2 (only for complete and completed vehicles);
- (b) the stage of completion (e.g. complete/incomplete/completed);
- (c) the power plant with regard to the following construction features:
 - (i) the type of energy supply (internal combustion engine, electric motor or other);
 - (ii) the working principle (positive ignition, compression ignition or other);
 - (iii) the number and arrangement of cylinders in the case of internal combustion engine (L6, V8 or other);
- (d) the number and interconnection of powered axles;
- (e) the number of steered axles;
- (f) in the case of multi-stage built vehicles, the manufacturer and the type of the previous stage vehicle.

4.3. Version

4.3.1. A 'version' within a variant shall group the vehicles that have the following features in common:

- (a) the technically permissible maximum laden mass;
- (b) the ability or not to tow a trailer as follows:
 - (i) an unbraked trailer;
 - (ii) a trailer with an inertia (or overrun) braking system as defined in paragraph 2.12 of UNECE Regulation No 13;
 - (iii) a trailer with a continuous or semi-continuous braking system as defined in paragraphs 2.9 and 2.10 of UNECE Regulation No 13;
 - (iv) a trailer of category O₄ that results in a maximum mass of the combination not exceeding 44 tonnes;
 - (v) a trailer of category O₄ that results in a maximum mass of the combination exceeding 44 tonnes;
- (c) the engine capacity;
- (d) the maximum engine power output;
- (e) the nature of the fuel (petrol, gas oil, LPG, bi-fuel or other);
- (f) drive-by sound level;
- (g) exhaust emission level (for example Euro IV, Euro V or other).

5. Categories O₁ and O₂

5.1. Type of vehicle

5.1.1. A 'type of vehicle' shall consist of vehicles that have the following features in common:

(a) the manufacturer's company name.

A change in the legal form of ownership of the company does not require that a new approval has to be granted;

(b) the category;

(c) the concept as defined in section 5 of Part C;

(d) the following aspects of construction and design:

(i) the design and construction of the essential constituent elements forming the chassis;

(ii) the design and construction of the essential constituent elements forming the body structure in the case of a self-supporting body;

(e) the number of axles.

5.1.2. A type of vehicle shall consist of at least one variant and one version.

5.2. Variant

5.2.1. A 'variant' within a type of vehicle shall group the vehicles that have the following construction features in common:

- (a) the kind of bodywork as referred to in Appendix 2 (for complete and completed vehicles);
- (b) the stage of completion (e.g. complete/incomplete/completed);
- (c) the type of braking system (e.g. unbraked/inertia/power).
- (d) in the case of multi-stage built vehicles, the manufacturer and the type of the previous stage vehicle.

5.3. Version

5.3.1. A 'version' within a variant shall group the vehicles that have the following features in common:

- (a) the technically permissible maximum laden mass;
- (b) the concept of the suspension (air, steel or rubber suspension, torsion bar or other);
- (c) the concept of the drawbar (triangle, tube or other).

6. Categories O₃ and O₄

6.1. Type of vehicle

6.1.1. A 'type of vehicle' shall consist of vehicles that have the following features in common:

(a) the manufacturer's company name.

A change in the legal form of ownership of the company does not require that a new approval has to be granted;

(b) the category;

(c) the concept of the trailer with relation to the definitions in section 5 of Part C;

(d) the following aspects of construction and design:

(i) the design and construction of the essential constituent elements forming the chassis;

(ii) the design and construction of the essential constituent elements forming the body structure in the case of trailers with a self-supporting body;

(e) the number of axles.

6.1.2. A type of vehicle shall consist of at least one variant and one version.

6.2. Variants

6.2.1. A 'variant' within a type of vehicle shall group the vehicles that have the following construction and design features in common:

- (a) the kind of bodywork as referred to in Appendix 2 (for complete and completed vehicles);
- (b) the stage of completion (e.g. complete/incomplete/completed);
- (c) the concept of the suspensions (steel, air or hydraulic suspension);
- (d) the following technical features:
 - (i) the capability or not for the chassis to be extendible;
 - (ii) the deck height (normal, low loader, semi-low loader etc.);
- (e) in the case of multi-stage built vehicles, the manufacturer and the type of the previous stage vehicle.

6.3. Versions

6.3.1. A 'version' within a variant shall group the vehicles that have the following features in common:

- (a) the technically permissible maximum laden mass;
- (b) the subdivisions or combination of subdivisions referred to in points 3.2 and 3.3 of Annex I to Council Directive 96/53/EC²⁰ into which the axle spacing between two consecutive axles forming a group belongs;
- (c) the definition of the axles in the following respects:
 - (i) lift axles (number and position);
 - (ii) loadable axles (number and position);
 - (iii) steered axle (number and position).

²⁰ Council Directive 96/53/EC of 25 July 1996 laying down for certain road vehicles circulating within the Community the maximum authorized dimensions in national and international traffic and the maximum authorized weights in international traffic (OJ L 235, 17.9.1996, p. 59).

7. Common requirements for all vehicle categories

7.1. When a vehicle falls into several categories because of its maximum mass or the number of seating positions or both, the manufacturer may select to use the criteria of one or the other vehicle category for the definition of the variants and the versions.

7.1.1. Examples:

- (a) a vehicle 'A' may be type-approved as N₁ (3,5 tonnes) and N₂ (4,2 tonnes) in relation to its maximum mass. In such a case, the parameters mentioned in category N₁ may be used also for the vehicle that falls into category N₂ (or vice-versa);
- (b) a vehicle 'B' may be type-approved as M₁ and M₂ in relation to the number of seating positions (7 + 1 or 10 + 1), the parameters mentioned in category M₁ may be used also for the vehicle that falls into category M₂ (or vice-versa).

7.2. A vehicle of category N may be type-approved against the provisions required for category M₁ or M₂, as the case may be, when it is intended to be converted into a vehicle of that category during the next step of a multi-stage type-approval procedure.

7.2.1. This option shall only be permitted for incomplete vehicles.

Such vehicles shall be identified by a specific variant code given by the manufacturer of the base vehicle.

7.3. Type-, variant- and version designations

7.3.1. The manufacturer shall allocate an alphanumeric code to each type of vehicle, variant and version, made up of Roman letters and/or Arabic numerals.

The use of brackets and hyphens is permitted provided they do not replace a letter or a numeral.

7.3.2. The whole code shall be designated: Type-Variant-Version or 'TVV'.

7.3.3. The TVV shall clearly and unequivocally identify a unique combination of technical features in relation to the criteria defined in Part B of this Annex.

7.3.4. The same manufacturer may use the same code in order to define a type of vehicle when the latter falls in two or more categories.

7.3.5. The same manufacturer shall not use the same code in order to define a type of vehicle for more than one type-approval within the same vehicle category.

7.4. Number of characters for the TVV

7.4.1. The number of characters shall not exceed:

- (a) 15 for the code of the type of vehicle;
- (b) 25 for the code of one variant;
- (c) 35 for the code of one version.

7.4.2. The complete alphanumeric 'TVV' shall not contain more than 75 characters.

7.4.3. When the TVV is used as a whole, a space shall be left between the type, the variant and the version.

Example of such TVV: 159AF[...space]0054[...space]977K(BE).

PART C

Definitions of types of bodywork

1. General

1.1. The type of bodywork referred to in section 9 of Annex I and Part 1 of Annex III as well as the code for bodywork referred to in item 38 of Annex IX shall be indicated by means of codes.

The list of codes shall apply primarily to complete and completed vehicles.

1.2. As regards vehicles of categories M, the type of bodywork shall consist of two letters as specified in sections 2 and 3.

1.3. As regards vehicles of categories N and O, the type of bodywork shall consist of two letters as referred to in sections 4 and 5.

1.4. Where necessary (especially for the types of bodywork referred to respectively in points 4.1 and 4.6 and in points 5.1 to 5.4), they shall be supplemented by two digits.

1.4.1. The list of digits shall be laid down in Appendix 2 to this Annex.

1.5. For special purpose vehicles, the type of bodywork to be used shall be linked to the category of the vehicle.

2. Vehicles belonging to category M₁

Ref.	Code	Name	Definition
2.1.	AA	Saloon	A vehicle defined in term 3.1.1.1 of Standard ISO 3833:1977, fitted with at least four side windows.
2.2.	AB	Hatchback	A saloon as defined in 2.1 with a hatch at the rear end of the vehicle.
2.3.	AC	Station wagon	A vehicle defined in term 3.1.1.4 of Standard ISO 3833:1977.
2.4.	AD	Coupé	A vehicle defined in term 3.1.1.5 of Standard ISO 3833:1977.
2.5.	AE	Convertible	A vehicle defined in terms No 3.1.1.6 of Standard ISO 3833:1977. However, a convertible may have no door.
2.6.	AF	Multi-purpose vehicle	A vehicle other than AG and those mentioned in AA to AE intended for carrying persons and their luggage or occasionally goods, in a single compartment.
2.7.	AG	Truck station wagon	A vehicle defined in term No 3.1.1.4.1 of Standard ISO 3833:1977. However, the luggage compartment must be completely separated from the passenger compartment. In addition, the reference point of the driver's seating position needs not to be at least at 750 mm above the surface supporting the vehicle.

3. Vehicles belonging to category M₂ or M₃

Ref.	Code	Name	Definition
3.1.	CA	Single-deck vehicle	A vehicle where the spaces provided for persons are arranged in a single level or in a way that they do not constitute two superimposed levels;
3.2.	CB	Double-deck vehicle	A vehicle defined in paragraph 2.1.6 of UNECE Regulation No 107;
3.3.	CC	Single-deck articulated vehicle	A vehicle defined in paragraph 2.1.3 of UNECE Regulation No 107 with a single deck;
3.4.	CD	Double-deck articulated vehicle	A vehicle defined in paragraph 2.1.3.1 of UNECE Regulation No 107;
3.5.	CE	Low-floor single-deck vehicle	A vehicle defined in paragraph 2.1.4 of UNECE Regulation No 107 with a single deck;
3.6.	CF	Low-floor double-deck vehicle	A vehicle defined in paragraph 2.1.4 of UNECE Regulation No 107 with a double deck;

3.7.	CG	Articulated low-floor single-deck vehicle	A vehicle that combines the technical features of points 3.3 and 3.5 of this table;
3.8.	CH	Articulated low-floor double-deck vehicle	A vehicle that combines the technical features of points 3.4 and 3.6 of this table;
3.9.	CI	Open top single deck vehicle	A vehicle with partial roof or without roof;
3.10.	CJ	Open top double deck vehicle	A vehicle without roof over all or part of its upper deck;
3.11.	CX	Bus chassis	An incomplete vehicle with just chassis rails or tube assembly, power train, axles, that is intended to be completed with bodywork, customised to the needs of the transport operator.

4. **Motor vehicles of category N₁, N₂ or N₃**

Ref.	Code	Name	Definition
4.1.	BA	Lorry	A vehicle that is designed and constructed exclusively or principally for conveying goods. It may also tow a trailer.
4.2.	BB	Van	A lorry with the compartment where the driver is located and cargo area within a single unit;
4.3.	BC	Tractor unit for semi-trailer	A towing vehicle that is designed and constructed exclusively or principally to tow semi-trailers;
4.4.	BD	Road tractor	A towing vehicle that is designed and constructed exclusively to tow trailers other than semi-trailers;
4.5.	BE	Pick-up truck	A vehicle of a maximum mass not exceeding 3 500 kg in which the seating positions and the cargo area are not located in a single compartment;
4.6.	BX	Chassis-cab or chassis-cowl	An incomplete vehicle with just a cabin (complete or partial), chassis rails, power train, axles, which is intended to be completed with bodywork, customised to the needs of the transport operator.

5. Vehicles of category O

Ref.	Code	Name	Definition
5.1.	DA	Semi-trailer	<p>A trailer that is designed and constructed to be coupled to a tractor unit or to a converter dolly and to impose a substantial vertical load on the towing vehicle or on the converter dolly.</p> <p>The coupling to be used for a vehicle combination shall consist of a king pin and a fifth wheel.</p>
5.2.	DB	Drawbar trailer	<p>A trailer having at least two axles, of which at least one is a steered axle:</p> <p>(a) equipped with a towing device which can move vertically (in relation to the trailer) and</p> <p>(b) that transmits less than 100 daN as a static vertical load to the towing vehicle.</p>
5.3.	DC	Centre-axle trailer	<p>A trailer where the axle(s) is (are) positioned close to the centre of gravity of the vehicle (when uniformly loaded) so that only a small static vertical load, not exceeding 10 % of that corresponding to the maximum mass of the trailer or a load of 1 000 daN (whichever is the lesser) is transmitted to the towing vehicle.</p>
5.4.	DE	Rigid drawbar trailer	<p>A trailer with one axle or one group of axles fitted with a drawbar which transmits a static load not exceeding 4 000 daN to the towing vehicle due to its construction and that does not meet the definition of a centre-axle trailer.</p> <p>The coupling to be used for a vehicle combination shall not consist of a king pin and a fifth wheel.</p>

Procedure for checking whether a vehicle can be categorised as off-road vehicle

1. **General**

1.1. For the purposes of classification of a vehicle as off-road vehicle, the procedure described in this Appendix shall apply.

2. **Test conditions for geometric measurements**

2.1. Vehicles belonging to category M₁ or N₁ shall be in unloaded conditions with a manikin of the 50th percentile male installed on the driver's seat and fitted with coolant fluid, lubricants, fuel, tools, spare-wheel (if fitted as OEM equipment).

The manikin may be replaced by a similar device having the same mass.

2.2. Vehicles other than those referred to in point 2.1 shall be loaded to their technically permissible maximum laden mass.

The distribution of the mass on the axles shall be the one that represents the worst case with respect to compliance with the respective criteria.

2.3. A vehicle representative of the type shall be submitted to the technical service in the conditions specified in point 2.1 or 2.2. The vehicle shall be in a stationary position with its wheels set straight ahead.

The ground on which measurements are made shall be as flat and horizontal (maximum of inclination 0,5 %) as possible.

3. **Measurement of approach, departure and ramp angles**

- 3.1. The approach angle shall be measured in accordance with paragraph 6.10 of Standard ISO 612:1978.
- 3.2. The departure angle shall be measured in accordance with paragraph 6.11 of Standard ISO 612:1978.
- 3.3. The ramp angle shall be measured in accordance with paragraph 6.9 of Standard ISO 612:1978.
- 3.4. When measuring the departure angle rear underrun protection devices which are adjustable in height may be set in the upper position.
- 3.5. The prescription in point 3.4 shall not be construed as an obligation for the base vehicle to be fitted with a rear underrun protection as original equipment. However, the base vehicle manufacturer shall inform the next stage manufacturer that the vehicle has to comply with the requirements on departure angle when fitted with a rear underrun protection.

4. Measurement of ground clearance

4.1. Ground clearance between the axles

4.1.1. 'Ground clearance between the axles' means the shortest distance between the ground plane and the lowest fixed point of the vehicle.

For the application of the definition, the distance between the last axle of a front group of axle and the first axle of a rear group of axle shall be considered.

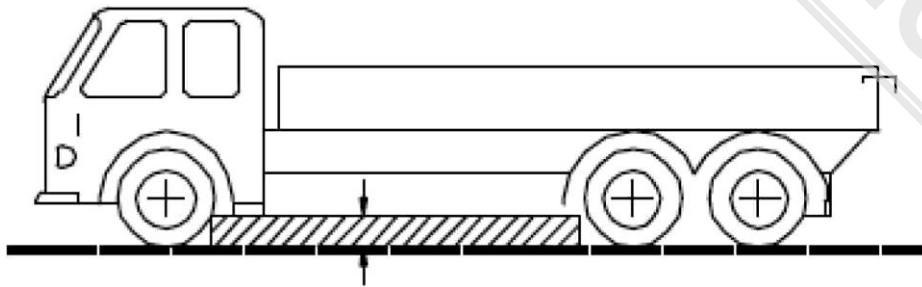

4.1.2. No rigid part of the vehicle may project into the shaded area shown on the figure.

4.2. Ground clearance beneath one axle

4.2.1. 'Ground clearance beneath one axle' means the distance beneath the highest point of the arc of a circle passing through the centre of the tyre footprint of the wheels on one axle (the inner wheels in the case of twin tyres) and touching the lowest fixed point of the vehicle between the wheels.

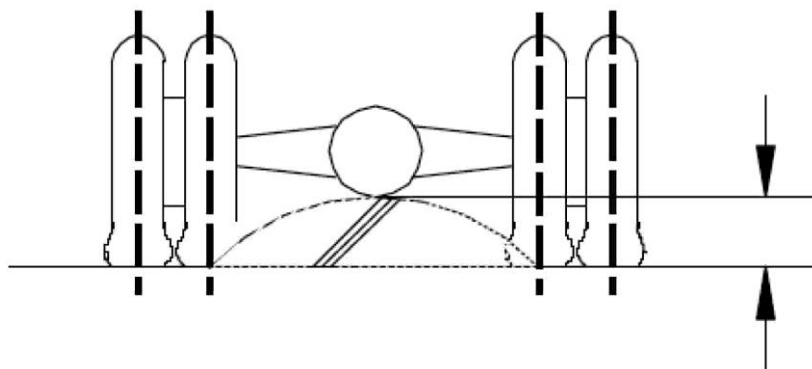

4.2.2. Where appropriate, the measurement of ground clearance shall be conducted on each of the several axles of a group of axles.

5. Gradeability
- 5.1. ‘Gradeability’ means the ability of a vehicle to negotiate a gradient.
- 5.2. To the effect of checking the gradeability of an incomplete and a complete vehicle of category M₂, M₃, N₂ and N₃, a test shall be performed.
- 5.3. The test shall be conducted by the technical service on a vehicle representative of the type to be tested.
- 5.4. At the request of the manufacturer and under the conditions specified in Annex XVI, the gradeability of a type of vehicle may be demonstrated by virtual testing.
6. Test conditions and pass-fail criterion
- 6.1. The conditions set out in Annex II to Regulation (EU) No 1230/2012 shall apply.
- 6.2. The vehicle shall climb the gradient at a steady speed without any wheel slipping, longitudinally or laterally.

Appendix 2

Digits used to supplement the codes to be used for various kinds of bodywork

- 01 Flat bed;
- 02 Drop-side;
- 03 Box body;
- 04 Conditioned body with insulated walls and equipment to maintain the interior temperature;
- 05 Conditioned body with insulated walls but without equipment to maintain the interior temperature;
- 06 Curtain-sided;
- 07 Swap body (interchangeable superstructure);
- 08 Container carrier;
- 09 Vehicles fitted with hook lift;
- 10 Tipper;
- 11 Tank;
- 12 Tank intended for transport of dangerous goods;
- 13 Livestock carrier;
- 14 Vehicle transporter;
- 15 Concrete mixer;
- 16 Concrete pump vehicle;
- 17 Timber;

- 18 Refuse collection vehicle;
- 19 Street sweeper, cleansing and drain clearing;
- 20 Compressor;
- 21 Boat carrier;
- 22 Glider carrier;
- 23 Vehicles for retail or display purposes;
- 24 Recovery vehicle;
- 25 Ladder vehicle;
- 26 Crane lorry (other than a mobile crane as defined in section 5 of Part A of Annex II);
- 27 Aerial work platform vehicle;
- 28 Digger derrick vehicle;
- 29 Low floor trailer;
- 30 Glazing transporter;
- 31 Fire engine;
- 99 Bodywork that is not included in the present list.

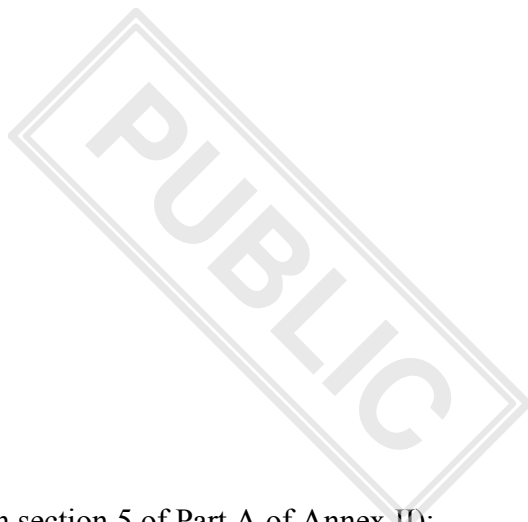

[...]

REQUIREMENTS FOR THE PURPOSE OF EU TYPE-APPROVAL OF VEHICLES, SYSTEMS,
COMPONENTS OR SEPARATE TECHNICAL UNITS

PART I

Regulatory acts for EU type-approval of vehicles produced in unlimited series

Item	Subject	Regulatory act	Applicability											STU or component
			M ₁	M ₂	M ₃	N ₁	N ₂	N ₃	O ₁	O ₂	O ₃	O ₄		
1A	Sound level	Regulation (EU) No 540/2014 of the European Parliament and of the Council ²¹	X	X	X	X	X	X						X
2A	Emissions (Euro 5 and 6) light duty vehicles/access to information	Regulation (EC) No 715/2007	X ⁽¹⁾	X ⁽¹⁾		X ⁽¹⁾	X ⁽¹⁾							X

²¹ Regulation (EU) No 540/2014 of the European Parliament and of the Council of 16 April 2014 on the sound level of motor vehicles and of replacement silencing systems, and amending Directive 2007/46/EC and repealing Directive 70/157/EEC (OJ L 158, 27.5.2014, p. 131).

3A	Prevention of fire risks (liquid fuel tanks)	Regulation (EC) No 661/2009 UNECE Regulation No 34	X	X	X	X	X	X	X	X	X	X	
3B	Rear underrun protective devices (RUPDs) and their installation; rear underrun protection (RUP)	Regulation (EC) No 661/2009 UNECE Regulation No 58	X	X	X	X	X	X	X	X	X	X	X
4A	Space for mounting and fixing rear registration plates	Regulation (EC) No 661/2009 Commission Regulation (EU) No 1003/2010 ²²	X	X	X	X	X	X	X	X	X	X	
5A	Steering equipment	Regulation (EC) No 661/2009 UNECE Regulation No 79	X	X	X	X	X	X	X	X	X	X	

²² Commission Regulation (EU) No 1003/2010 of 8 November 2010 concerning type-approval requirements for the space for mounting and the fixing of rear registration plates on motor vehicles and their trailers and implementing Regulation (EC) No 661/2009 of the European Parliament and of the Council concerning type-approval requirements for the general safety of motor vehicles, their trailers and systems, components and separate technical units intended therefor (OJ L 291, 9.11.2010, p. 22).

6A	Vehicle access and manoeuvrability (steps, running boards and handholds)	Regulation (EC) No 661/2009 Regulation (EU) No 130/2012 ²³	X			X	X	X					
6B	Door latches and door retention components	Regulation (EC) No 661/2009 UNECE Regulation No 11	X			X							
7A	Audible warning devices and signals	Regulation (EC) No 661/2009 UNECE Regulation No 28	X	X	X	X	X	X					X
8A	Devices for indirect vision and their installation	Regulation (EC) No 661/2009 UNECE Regulation No 46	X	X	X	X	X	X					X
9A	Braking of vehicles and trailers	Regulation (EC) No 661/2009 UNECE Regulation No 13		X ⁽³⁾	X ⁽³⁾	X ⁽³⁾	X ⁽³⁾	X ⁽³⁾	X ⁽³⁾	X ⁽³⁾	X ⁽³⁾	X ⁽³⁾	

²³ Commission Regulation (EU) No 130/2012 of 15 February 2012 concerning type-approval requirements for motor vehicles with regard to vehicle access and manoeuvrability and implementing Regulation (EC) No 661/2009 of the European Parliament and of the Council concerning type-approval requirements for the general safety of motor vehicles, their trailers and systems, components and separate technical units intended therefor (OJ L 43, 16.2.2012, p. 6).

9B	Braking of passenger cars	Regulation (EC) No 661/2009 UNECE Regulation No 13-H	X ⁽⁴⁾			X ⁽⁴⁾							
10A	Electromagnetic compatibility	Regulation (EC) No 661/2009 UNECE Regulation No 10	X	X	X	X	X	X	X	X	X	X	X
12A	Interior fittings	Regulation (EC) No 661/2009 UNECE Regulation No 21	X										
13A	Protection of motor vehicles against unauthorised use	Regulation (EC) No 661/2009 UNECE Regulation No 18		X ^(4A)	X ^(4A)		X ^(4A)	X ^(4A)					X
13B	Protection of motor vehicles against unauthorised use	Regulation (EC) No 661/2009 UNECE Regulation No 116	X			X							X

14A	Protection of the driver against the steering mechanism in the event of impact	Regulation (EC) No 661/2009 UNECE Regulation No 12	X			X								
15A	Seats, their anchorages and any head restraints	Regulation (EC) No 661/2009 UNECE Regulation No 17	X	X ^(4B)	X ^(4B)	X	X	X						
15B	Seats of large passenger vehicles	Regulation (EC) No 661/2009 UNECE Regulation No 80		X	X									
16A	External projections	Regulation (EC) No 661/2009 UNECE Regulation No 26	X											X
17A	Vehicle access and manoeuvrability (reverse gear)	Regulation (EC) No 661/2009 Regulation (EU) No 130/2012	X	X	X	X	X	X						
17B	Speedometer equipment including its installation	Regulation (EC) No 661/2009 UNECE Regulation No 39	X	X	X	X	X	X						

18A	Manufacturer's statutory plate and vehicle identification number	Regulation (EC) No 661/2009 Regulation (EU) No 19/2011	X	X	X	X	X	X	X	X	X	X	X	
19A	Safety-belt anchorages, Isofix anchorages systems and Isofix top tether anchorages	Regulation (EC) No 661/2009 UNECE Regulation No 14	X	X	X	X	X	X						
20A	Installation of lighting and light-signalling devices on vehicles	Regulation (EC) No 661/2009 UNECE Regulation No 48	X	X	X	X	X	X	X	X	X	X	X	
21A	Retro-reflecting devices for power-driven vehicles and their trailers	Regulation (EC) No 661/2009 UNECE Regulation No 3	X	X	X	X	X	X	X	X	X	X	X	X
22A	Front and rear position lamps, stop-lamps and end-outline marker lamps for motor vehicles and their trailers	Regulation (EC) No 661/2009 UNECE Regulation No 7	X	X	X	X	X	X	X	X	X	X	X	X

22B	Daytime running lamps for power-driven vehicles	Regulation (EC) No 661/2009 UNECE Regulation No 87	X	X	X	X	X	X					X
22C	Side-marker lamps for motor vehicles and their trailers	Regulation (EC) No 661/2009 UNECE Regulation No 91	X	X	X	X	X	X	X	X	X	X	X
23A	Direction indicators for power-driven vehicles and their trailers	Regulation (EC) No 661/2009 UNECE Regulation No 6	X	X	X	X	X	X	X	X	X	X	X
24A	Illumination of rear-registration plates of power-driven vehicles and their trailers	Regulation (EC) No 661/2009 UNECE Regulation No 4	X	X	X	X	X	X	X	X	X	X	X
25A	Power-driven vehicle's sealed-beam headlamps (SB) emitting an European asymmetrical passing beam or a driving beam or both	Regulation (EC) No 661/2009 UNECE Regulation No 31	X	X	X	X	X	X					X

25B	Filament lamps for use in approved lamp units of power-driven vehicles and their trailers	Regulation (EC) No 661/2009 UNECE Regulation No 37	X	X	X	X	X	X	X	X	X	X	X	X
25C	Motor vehicle headlamps equipped with gas-discharge light sources	Regulation (EC) No 661/2009 UNECE Regulation No 98	X	X	X	X	X	X						X
25D	Gas-discharge light sources for use in approved gas-discharge lamp units of power-driven vehicles	Regulation (EC) No 661/2009 UNECE Regulation No 99	X	X	X	X	X	X						X
25E	Motor vehicle headlamps emitting an asymmetrical passing beam or a driving beam or both and equipped with filament lamps and/or LED modules	Regulation (EC) No 661/2009 UNECE Regulation No 112	X	X	X	X	X	X						X

25F	Adaptive front-lighting systems (AFS) for motor vehicles	Regulation (EC) No 661/2009 UNECE Regulation No 123	X	X	X	X	X	X					X
26A	Power-driven vehicle front fog lamps	Regulation (EC) No 661/2009 UNECE Regulation No 19	X	X	X	X	X	X					X
27A	Towing device	Regulation (EC) No 661/2009 Regulation (EU) No 1005/2010	X	X	X	X	X	X					
28A	Rear fog lamps for power-driven vehicles and their trailers	Regulation (EC) No 661/2009 UNECE Regulation No 38	X	X	X	X	X	X	X	X	X	X	X
29A	Reversing lights for power-driven vehicles and their trailers	Regulation (EC) No 661/2009 UNECE Regulation No 23	X	X	X	X	X	X	X	X	X	X	X
30A	Parking lamps for power-driven vehicles	Regulation (EC) No 661/2009 UNECE Regulation No 77	X	X	X	X	X	X					

31A	Safety-belts, restraint systems, child restraint systems and Isofix child restraint systems	Regulation (EC) No 661/2009 UNECE Regulation No 16	X	X	X	X	X	X					X
32A	Forward field of vision	Regulation (EC) No 661/2009 UNECE Regulation No 125	X										
33A	Location and identification of hand controls, tell-tales and indicators	Regulation (EC) No 661/2009 UNECE Regulation No 121	X	X	X	X	X	X					
34A	Windscreen defrosting and demisting systems	Regulation (EC) No 661/2009 Commission Regulation (EU) No 672/2010 ²⁴	X	(⁵)	(⁵)	(⁵)	(⁵)	(⁵)					

²⁴ Commission Regulation (EU) No 672/2010 of 27 July 2010 concerning type-approval requirements for windscreen defrosting and demisting systems of certain motor vehicles and implementing Regulation (EC) No 661/2009 of the European Parliament and of the Council concerning type-approval requirements for the general safety of motor vehicles, their trailers and systems, components and separate technical units intended therefor (OJ L 196, 28.7.2010, p. 5).

35A	Windscreen wiper and washer systems	Regulation (EC) No 661/2009 Commission Regulation (EU) No 1008/2010 ²⁵	X	(⁶)	(⁶)	(⁶)	(⁶)	(⁶)						X
36A	Heating systems	Regulation (EC) No 661/2009 UNECE Regulation No 122	X	X	X	X	X	X	X	X	X	X	X	X
37A	Wheel guards	Regulation (EC) No 661/2009 Regulation (EU) No 1009/2010	X											
38A	Head restraints (headrests), whether or not incorporated in vehicle seats	Regulation (EC) No 661/2009 UNECE Regulation No 25	X											
41A	Emissions (Euro VI) heavy duty vehicles/access to information	Regulation (EC) No 595/2009	X(⁹)	X(⁹)	X	X(⁹)	X(⁹)	X						X

²⁵ Commission Regulation (EU) No 1008/2010 of 9 November 2010 concerning type-approval requirements for windscreen wiper and washer systems of certain motor vehicles and implementing Regulation (EC) No 661/2009 of the European Parliament and of the Council concerning type-approval requirements for the general safety of motor vehicles, their trailers and systems, components and separate technical units intended therefor (OJ L 292, 10.11.2010, p. 2).

42A	Lateral protection of goods vehicles	Regulation (EC) No 661/2009 UNECE Regulation No 73					X	X			X	X	X
43A	Spray suppression systems	Regulation (EC) No 661/2009 Regulation (EU) No 109/2011				X	X	X	X	X	X	X	X
44A	Masses and dimensions	Regulation (EC) No 661/2009 Regulation (EU) No 1230/2012	X										
45A	Safety glazing materials and their installation on vehicles	Regulation (EC) No 661/2009 UNECE Regulation No 43	X	X	X	X	X	X	X	X	X	X	X
46	Tyres	Directive 92/23/EEC ²⁶	X	X	X	X	X	X	X	X	X	X	X
46A	Installation of tyres	Regulation (EC) No 661/2009 Commission Regulation (EU) No 458/2011 ²⁷	X	X	X	X	X	X	X	X	X	X	

²⁶ Council directive 92/23/EEC of 31 March 1992 relating to tyres for motor vehicles and their trailers and to their fitting (**OJ** L 129, 14.5.1992, p. 95).

²⁷ Commission Regulation (EU) No 458/2011 of 12 May 2011 concerning type-approval requirements for motor vehicles and their trailers with regard to the installation of their tyres and implementing Regulation (EC) No 661/2009 of the European Parliament and of the Council concerning type-approval requirements for the general safety of motor vehicles, their trailers and systems, components and separate technical units intended therefor (**OJ** L 124, 13.5.2011, p. 11).

46B	Pneumatic tyres for motor vehicles and their trailers (Class C1)	Regulation (EC) No 661/2009 UNECE Regulation No 30	X			X		X	X			X
46C	Pneumatic tyres for commercial vehicles and their trailers (Classes C2 and C3)	Regulation (EC) No 661/2009 UNECE Regulation No 54		X	X	X	X	X		X	X	X
46D	Tyre rolling sound emissions, adhesion on wet surfaces and rolling resistance (Classes C1, C2 and C3)	Regulation (EC) No 661/2009 UNECE Regulation No 117	X	X	X	X	X	X	X	X	X	X
46E	Temporary-use spare unit, run-flat tyres/system and tyre pressure monitoring system	Regulation (EC) No 661/2009 UNECE Regulation No 64	X ^(9A)			X ^(9A)						X

47A	Speed limitation of vehicles	Regulation (EC) No 661/2009 UNECE Regulation No 89		X	X		X	X					X
48A	Masses and dimensions	Regulation (EC) No 661/2009 Regulation (EU) No 1230/2012		X	X	X	X	X	X	X	X	X	
49A	Commercial vehicles with regard to their external projections forward of the cab's rear panel	Regulation (EC) No 661/2009 UNECE Regulation No 61				X	X	X					
50A	Mechanical coupling components of combinations of vehicles	Regulation (EC) No 661/2009 UNECE Regulation No 55	X ⁽¹⁰⁾	X ⁽¹⁰⁾	X ⁽¹⁰⁾	X ⁽¹⁰⁾	X ⁽¹⁰⁾	X ⁽¹⁰⁾	X	X	X	X	X
50B	Close-coupling device (CCD); fitting of an approved type of CCD	Regulation (EC) No 661/2009 UNECE Regulation No 102					X ⁽¹⁰⁾	X ⁽¹⁰⁾			X ⁽¹⁰⁾	X ⁽¹⁰⁾	X

51A	Burning behaviour of materials used in the interior construction of certain categories of motor vehicles	Regulation (EC) No 661/2009 UNECE Regulation No 118			X									
52A	M ₂ and M ₃ vehicles	Regulation (EC) No 661/2009 UNECE Regulation No 107		X	X									
52B	Strength of the superstructure of large passenger vehicles	Regulation (EC) No 661/2009 UNECE Regulation No 66		X	X									
53A	Protection of occupants in the event of a frontal collision	Regulation (EC) No 661/2009 UNECE Regulation No 94	X ⁽¹¹⁾											
54A	Protection of occupants in the event of lateral collision	Regulation (EC) No 661/2009 UNECE Regulation No 95	X ⁽¹²⁾			X ⁽¹²⁾								
55	(empty)													

56A	Vehicles for the carriage of dangerous goods	Regulation (EC) No 661/2009 UNECE Regulation No 105				X ⁽¹³⁾	X ⁽¹³⁾	X ⁽¹³⁾	X ⁽¹³⁾	X ⁽¹³⁾	X ⁽¹³⁾	X ⁽¹³⁾	
57A	Front underrun protective devices (FUPDs) and their installation; front underrun protection (FUP)	Regulation (EC) No 661/2009 UNECE Regulation No 93					X	X					X
58	Pedestrian protection	Regulation (EC) No 78/2009 of the European Parliament and of the Council ²⁸	X			X							X
59	Recyclability	Directive 2005/64/EC of the European Parliament and of the Council ²⁹	X			X		-					
60	(empty)												

²⁸ Regulation (EC) No 78/2009 of the European Parliament and of the Council of 14 January 2009 on the type-approval of motor vehicles with regard to the protection of pedestrians and other vulnerable road users, amending Directive 2007/46/EC and repealing Directives 2003/102/EC and 2005/66/EC (OJ L 035, 4.2.2009, p.1).

²⁹ Directive 2005/64/EC of the European Parliament and of the Council of 26 October 2005 on the type-approval of motor vehicles with regard to their reusability, recyclability and recoverability and amending Council Directive 70/156/EEC (OJ L 310, 25.11.2005, p. 10).

61	Air-conditioning systems	Directive 2006/40/EC of the European Parliament and of the Council ³⁰	X			X ⁽¹⁴⁾							
62	Hydrogen system	Regulation (EC) No 79/2009	X	X	X	X	X	X					
63	General Safety	Regulation (EC) No 661/2009	X ⁽¹⁵⁾	X ⁽¹⁵⁾	X ⁽¹⁵⁾	X ⁽¹⁵⁾	X ⁽¹⁵⁾	X ⁽¹⁵⁾	X ⁽¹⁵⁾	X ⁽¹⁵⁾	X ⁽¹⁵⁾	X ⁽¹⁵⁾	X ⁽¹⁵⁾
64	Gear shift indicators	Regulation (EC) No 661/2009 Regulation (EU) No 65/2012	X										
65	Advanced emergency braking system	Regulation (EC) No 661/2009 Commission Regulation (EU) No 347/2012 ³¹		X	X		X	X					
66	Lane departure warning system	Regulation (EC) No 661/2009 Commission Regulation (EU) No 351/2012 ³²		X	X		X	X					

³⁰ Directive 2006/40/EC of the European Parliament and of the Council of 17 May 2006 relating to emissions from air conditioning systems in motor vehicles and amending Council Directive 70/156/EEC (OJ L 161, 14.6.2006, p. 12).

³¹ Commission Regulation (EU) No 347/2012 of 16 April 2012 implementing Regulation (EC) No 661/2009 of the European Parliament and of the Council with respect to type-approval requirements for certain categories of motor vehicles with regard to advanced emergency braking systems (OJ L 109, 21.4.2012, p. 1).

³² Commission Regulation (EU) No 351/2012 of 23 April 2012 implementing Regulation (EC) No 661/2009 of the European Parliament and of the Council as regards type-approval requirements for the installation of lane departure warning systems in motor vehicles (OJ L 110, 24.4.2012, p. 18).

67	Specific components for liquefied petroleum gases (LPG) and their installation on motor vehicles	Regulation (EC) No 661/2009 UNECE Regulation No 67	X	X	X	X	X	X						X
68	Vehicle alarm systems (VAS)	Regulation (EC) No 661/2009 UNECE Regulation No 97	X			X								X
69	Electric safety	Regulation (EC) No 661/2009 UNECE Regulation No 100	X	X	X	X	X	X						
70	Specific components for CNG and their installation on motor vehicles	Regulation (EC) No 661/2009 UNECE Regulation No 110	X	X	X	X	X	X						X
71	Cab strength	Regulation (EC) No 661/2009 UNECE Regulation No 29				X	X	X						
72	eCall system	Regulation (EU) 2015/758	X			X								

Explanatory notes

X Relevant regulatory act.

- (¹) For vehicles with a reference mass not exceeding 2 610 kg. At the manufacturer's request, Regulation (EC) No 715/2007 may apply to vehicles with a reference mass not exceeding 2 840 kg.
- (²) In case of vehicles equipped with a LPG or CNG installation, a vehicle type-approval in accordance with UNECE Regulation No 67 or UNECE Regulation No 110 is required.
- (³) The fitting of an electronic stability control ('ESC') system is required in accordance with Article 12 and Article 13 of Regulation (EC) No 661/2009.
- (⁴) The fitting of an ESC system is required in accordance with Article 12 and Article 13 of Regulation (EC) No 661/2009.
- (^{4A}) If fitted, the protective device shall fulfil the requirements of UNECE Regulation No 18.
- (^{4B}) This Regulation applies to seats not falling within the scope of UNECE Regulation No 80.
- (⁹) For vehicles with a reference mass exceeding 2 610 kg which are not type-approved (at the manufacturer's request and provided their reference mass does not exceed 2 840 kg) under Regulation (EC) No 715/2007.
- (^{9A}) Applies only where such vehicles are fitted with equipment covered by UNECE Regulation No 64. Tyre pressure monitoring system for M1 vehicles applies on a compulsory basis in accordance with Article 9(2) of Regulation (EC) No 661/2009.
- (¹⁰) Applies only to vehicles equipped with coupling(s).
- (¹¹) Applies to vehicles with a technically permissible maximum laden mass not exceeding 2,5 tonnes.
- (¹²) Only applicable to vehicles where the 'Seating Reference Point ("R" point)' of the lowest seat is not more than 700 mm above the ground level.
- (¹³) Applies only when the manufacturer applies for type-approval of vehicles intended for the transport of dangerous goods.
- (¹⁴) Applies only for vehicles of category N₁, class I as described in Annex I to Regulation (EC) No 715/2007.
- (¹⁵) Compliance with Regulation (EC) No 661/2009 is mandatory, however, type-approval under this item number is not foreseen as it represents the collection of individual items 3A, 3B, 4A, 5A, 6A, 6B, 7A, 8A, 9A, 9B, 10A, 12A, 13A, 13B, 14A, 15A, 15B, 16A, 17A, 17B, 18A, 19A, 20A, 21A, 22A, 22B, 22C, 23A, 24A, 25A, 25B, 25C, 25D, 25E, 25F, 26A, 27A, 28A, 29A, 30A, 31A, 32A, 33A, 34A, 35A, 36A, 37A, 38A, 42A, 43A, 44A, 45A, 46A, 46B, 46C, 46D, 46E, 47A, 48A, 49A, 50A, 50B, 51A, 52A, 52B, 53A, 54A, 56A, 57A and 64 to 71. The series of amendments of the UNECE regulations which apply on a compulsory basis are listed in Annex IV to Regulation (EC) No 661/2009. The series of amendments adopted subsequently are accepted as an alternative.

Appendix 1

Regulatory acts for EU type-approval of vehicles produced in small series pursuant to Article 39

Table 1

M₁ vehicles

Item	Subject	Regulatory act	Specific issues	Applicability and specific requirements
1	Sound level	Directive 70/157/EEC		A
1A	Sound level	Regulation (EU) No 540/2014		A

2	Emissions (Euro 5 and 6) light duty vehicles/access to information	Regulation (EC) No 715/2007		A
			(a) On-board diagnostic (OBD)	<p>The vehicle shall be fitted with an OBD system that fulfils the requirements of Article 4(1) and (2) of Regulation (EC) No 692/2008 (The OBD system shall be designed to record at least the malfunction of the engine management system).</p> <p>The OBD-interface shall be able to communicate with commonly available diagnostic tools.</p>
			(b) In service conformity	N/A
			(c) Access to information	It is sufficient that the manufacturer provide access to repair and maintenance information in a readily accessible and prompt manner.
			(d) Power measurement	<p><i>(When the vehicle manufacturer uses an engine from another manufacturer)</i></p> <p>Bench test data from the engine manufacturer are accepted provided that the engine management system is identical (i.e. having at least the same electronic control unit (ECU)).</p> <p>Power output test may be performed on a chassis dynamometer. It shall be taken into account of the power loss in the transmission.</p>

Item	Subject	Regulatory act	Specific issues	Applicability and specific requirements
3A	Prevention of fire risks (liquid fuel tanks)	Regulation (EC) No 661/2009	(a) Liquid fuel tanks	B
		UNECE Regulation No 34	(b) Installation in vehicle	B
3B	Rear underrun protective devices (RUPDs) and their installation; rear underrun protection (RUP)	Regulation (EC) No 661/2009 UNECE Regulation No 58		B
4A	Space for mounting and fixing rear registration plates	Regulation (EC) No 661/2009 Regulation (EU) No 1003/2010		B
5A	Steering equipment	Regulation (EC) No 661/2009 UNECE Regulation No 79	(a) Mechanical systems	The provisions of paragraph 5 of UNECE Regulation No 79 shall apply. All tests prescribed in paragraph 6.2 of UNECE Regulation No 79 shall be performed and the requirements of paragraph 6.1 of UNECE Regulation No 79 shall apply.
			(b) Complex electronic vehicle control system	All the requirements of Annex 6 of UNECE Regulation No 79 shall apply. Compliance with these requirements may only be checked by a technical service.

6A	Door latches and door retention components	Regulation (EC) No 661/2009 UNECE Regulation No 11	(a) General requirements (Paragraph 5 of UNECE Regulation No 11)	C All the requirements shall apply.
			(b) Performance requirements (Paragraph 6 of UNECE Regulation No 11)	Only the requirements of paragraph 6.1.5.4 and paragraph 6.3 of UNECE Regulation No 11 shall apply.
7A	Audible warning devices and signals	Regulation (EC) No 661/2009 UNECE Regulation No 28	(a) Components	X
			(b) Installation on vehicle	B

Item	Subject	Regulatory act	Specific issues	Applicability and specific requirements
8A	Devices for indirect vision and their installation	Regulation (EC) No 661/2009 UNECE Regulation No 46	(a) Components	X
			(b) Installation on vehicle	B
9B	Braking	Regulation (EC) No 661/2009 UNECE Regulation No 13-H	(a) Design and tests requirements	A
			(b) Electronic stability control (ESC) and brake assist systems (BAS)	The fitting of BAS and ESC shall not be required. If fitted, they shall comply with the requirements of UNECE Regulation No 13-H.
10A	Electromagnetic compatibility	Regulation (EC) No 661/2009 UNECE Regulation No 10		B

12A	Interior fittings	Regulation (EC) No 661/2009 UNECE Regulation No 21		C
			(a) Interior arrangement	
			(i) Radii and protrusion requirements for switches, pull-knobs and the like, controls and general interior fittings	The requirements of paragraphs 5.1 to 5.6 of UNECE Regulation No 21 may be waived at the request of the manufacturer. The requirements of paragraph 5.2 of UNECE Regulation No 21 with the exception of paragraphs 5.2.3.1, 5.2.3.2 and 5.2.4 of that Regulation shall apply.
			(ii) Energy absorption tests on the upper dashboard	Energy absorption tests on the upper dashboard shall only be performed when the vehicle is not fitted with at least two front airbags or two static four-point harnesses.
			(iii) Energy absorption test on the rear part of the seats	N/A
			(b) Power-operation of windows, roof-panel systems and partition systems	All requirements of paragraph 5.8 of UNECE Regulation No 21 shall apply.

Item	Subject	Regulatory act	Specific issues	Applicability and specific requirements
13A	Protection of motor vehicles against unauthorised use	Regulation (EC) No 661/2009 UNECE Regulation No 116		A The provisions of paragraph 8.3.1.1.1. of UNECE Regulation No 116 may be applied instead of paragraph 8.3.1.1.2. of that Regulation regardless of the type of powertrain
14A	Protection of the driver against the steering mechanism in the event of impact	Regulation (EC) No 661/2009 UNECE Regulation No 12		C
				Tests are required when the vehicle has not been tested under UNECE Regulation No 94 (see item 53A)

15A	Seats, their anchorages and any head restraints	Regulation (EC) No 661/2009 UNECE Regulation No 17		C
			(a) General requirements	Requirements of paragraph 5.2 of UNECE Regulation No 17 shall apply with the exception of paragraph 5.2.3 of that Regulation.
			(i) Specifications	
			(ii) Strength tests for seat backrest and head restraints	The requirements of paragraph 6.2 of UNECE Regulation No 17 shall apply.
			(iii) Unlocking and adjustment tests	The test shall be performed in accordance with the requirements of Annex 7 to UNECE Regulation No 17.
			(b) Head restraints	Requirements of paragraphs 5.4, 5.5, 5.6, 5.10, 5.11 and 5.12 of UNECE Regulation No 17 shall apply with the exception of paragraph 5.5.2 of that Regulation.
			(i) Specifications	
			(ii) Strength tests on head restraints	The test prescribed in paragraph 6.4 of UNECE Regulation No 17 shall be performed.
			(c) Special requirements regarding the protection of occupants from displaced luggage	The requirements of Annex 9 to UNECE Regulation No 26 may be waived at the request of the manufacturer.

16A	External projections	Regulation (EC) No 661/2009 UNECE Regulation No 26		C
			(a) General specifications	The requirements of paragraph 5 of UNECE Regulation No 26 shall apply.
			(b) Particular specifications	The requirements of paragraph 6 of UNECE Regulation No 26 shall apply.
17A	Vehicle access and manoeuvrability	Regulation (EC) No 661/2009 Regulation (EU) No 130/2012		D
Item	Subject	Regulatory act	Specific issues	Applicability and specific requirements
17B	Speedometer equipment including its installation	Regulation (EC) No 661/2009 UNECE Regulation No 39		B
18A	Manufacturer's statutory plate and vehicle identification number	Regulation (EC) No 661/2009 Regulation (EU) No 19/2011		B
19A	Safety-belt anchorages, Isofix anchorages systems and Isofix top tether anchorages	Regulation (EC) No 661/2009 UNECE Regulation No 14		B

20A	Installation of lighting and light-signalling devices on vehicles	Regulation (EC) No 661/2009 UNECE Regulation No 48		B Daytime Running Lights (DRL) shall be fitted to a new type of vehicle.
21A	Retro-reflecting devices for power-driven vehicles and their trailers	Regulation (EC) No 661/2009 UNECE Regulation No 3		X
22A	Front and rear position lamps, stop-lamps and end-outline marker lamps for motor vehicles and their trailers	Regulation (EC) No 661/2009 UNECE Regulation No 7		X
22B	Daytime running lamps for power-driven vehicles	Regulation (EC) No 661/2009 UNECE Regulation No 87		X
22C	Side-marker lamps for motor vehicles and their trailers	Regulation (EC) No 661/2009 UNECE Regulation No 91		X
23A	Direction indicators for power-driven vehicles and their trailers	Regulation (EC) No 661/2009 UNECE Regulation No 6		X
24A	Illumination of rear-registration plates of power-driven vehicles and their trailers	Regulation (EC) No 661/2009 UNECE Regulation No 4		X

Item	Subject	Regulatory act	Specific issues	Applicability and specific requirements
25A	Power-driven vehicle's sealed-beam headlamps (SB) emitting an European asymmetrical passing beam or a driving beam or both	Regulation (EC) No 661/2009 UNECE Regulation No 31		X
25B	Filament lamps for use in approved lamp units of power-driven vehicles and their trailers	Regulation (EC) No 661/2009 UNECE Regulation No 37		X
25C	Motor vehicle headlamps equipped with gas-discharge light sources	Regulation (EC) No 661/2009 UNECE Regulation No 98		X
25D	Gas-discharge light sources for use in approved gas-discharge lamp units of power-driven vehicles	Regulation (EC) No 661/2009 UNECE Regulation No 99		X

25E	Motor vehicle headlamps emitting an asymmetrical passing beam or a driving beam or both and equipped with filament lamps and/or LED modules	Regulation (EC) No 661/2009 UNECE Regulation No 112		X
25F	Adaptive front-lighting systems (AFS) for motor vehicles	Regulation (EC) No 661/2009 UNECE Regulation No 123		X
26A	Power-driven vehicle front fog lamps	Regulation (EC) No 661/2009 UNECE Regulation No 19		X
27A	Towing device	Regulation (EC) No 661/2009 Regulation (EU) No 1005/2010		B
28A	Rear fog lamps for power-driven vehicles and their trailers	Regulation (EC) No 661/2009 UNECE Regulation No 38		X

Item	Subject	Regulatory act	Specific issues	Applicability and specific requirements
29A	Reversing lights for power-driven vehicles and their trailers	Regulation (EC) No 661/2009 UNECE Regulation No 23		X
30A	Parking lamps for power-driven vehicles	Regulation (EC) No 661/2009 UNECE Regulation No 77		X
31A	Safety-belts, restraint systems, child restraint systems and Isofix child restraint systems	Regulation (EC) No 661/2009 UNECE Regulation No 16	(a) Components	X
			(b) Installation requirements	B
32A	Forward field of vision	Regulation (EC) No 661/2009 UNECE Regulation No 125		A
33A	Location and identification of hand controls, tell-tales and indicators	Regulation (EC) No 661/2009 UNECE Regulation No 121		A

34A	Windscreen defrosting and demisting systems	Regulation (EC) No 661/2009 Regulation (EU) No 672/2010		C
			(a) Windscreen defrosting	Only point 1.1.1 of Annex II to Regulation (EU) No 672/2010 shall apply, provided that warm air flow is ducted to the whole surface of the windscreen or the latter is electrically heated on its whole surface.
			(b) Windscreen demisting	Only point 1.2.1 of Annex II to Regulation (EU) No 672/2010 shall apply, provided that warm air flow is ducted to the whole surface of the windscreen or the latter is electrically heated on its whole surface.
35A	Windscreen wiper and washer systems	Regulation (EC) No 661/2009 Regulation (EU) No 1008/2010		C
			(a) Windscreen wiper system	Points 1.1 to 1.1.10 of Annex III to Regulation (EU) No 1008/2010 shall apply. Only the test described in point 2.1.10 of Annex III to Regulation (EU) No 1008/2010 shall be performed.
			(b) Windscreen washer system	Point 1.2 of Annex III to Regulation (EU) No 1008/2010 shall apply with the exception of points 1.2.2, 1.2.3 and 1.2.5.

Item	Subject	Regulatory act	Specific issues	Applicability and specific requirements
36A	Heating system	Regulation (EC) No 661/2009 UNECE Regulation No 122		C The fitting of a heating system shall not be required.
			(a) All heating systems	The requirements of paragraphs 5.3 and 6 of UNECE Regulation No 122 shall apply.
			(b) LPG heating systems	The requirements of Annex 8 to UNECE Regulation No 122 shall apply.
37A	Wheel guards	Regulation (EC) No 661/2009 Regulation (EU) No 1009/2010		B
38A	Head restraints	Regulation (EC) No 661/2009 UNECE Regulation No 25		X

41A	Emissions (Euro VI) heavy duty vehicles/access to information	Regulation (EC) No 595/2009		A With the exception of the set of requirements relating to OBDS and access to information.
			Power measurement	<i>(When the vehicle manufacturer uses an engine from another manufacturer)</i> Bench test data from the engine manufacturer are accepted, provided that the engine management system is identical (i.e. having at least the same ECU). Power output test may be performed on a chassis dynamometer. It shall be taken into account of the power loss in the transmission.
44A	Masses and dimensions	Regulation (EC) No 661/2009 Regulation (EU) No 1230/2012		B The hill start test at maximum combination mass described in point 5.1 of Part A of Annex I to Regulation (EU) No 1230/2012 may be waived at the request of the manufacturer.
45A	Safety glazing materials and their installation on vehicles	Regulation (EC) No 661/2009 UNECE Regulation No 43	(a) Components	X
			(b) Installation	B
46	Tyres	Directive 92/23/EEC	Components	X

Item	Subject	Regulatory act	Specific issues	Applicability and specific requirements
46A	Installation of tyres	Regulation (EC) No 661/2009 Regulation (EU) No 458/2011		B Dates for progressive application shall be those set out in Article 13 of Regulation (EC) No 661/2009.
46B	Pneumatic tyres for motor vehicles and their trailers (Class C1)	Regulation (EC) No 661/2009 UNECE Regulation No 30	Components	X
46D	Tyre rolling sound emissions, adhesion on wet surfaces and rolling resistance (classes C1, C2 and C3)	Regulation (EC) No 661/2009 UNECE Regulation No 117	Components	X
46E	Temporary-use spare unit, run-flat tyres/system and tyre pressure monitoring system	Regulation (EC) No 661/2009 UNECE Regulation No 64	Components	X
			Fitting of a tyre-pressure monitoring system (TPMS)	B The fitting of a TPMS shall not be required.
50A	Mechanical coupling components of combinations of vehicles	Regulation (EC) No 661/2009 UNECE Regulation No 55	(a) Components	X
			(b) Installation	B

53A	Protection of occupants in the event of a frontal collision	Regulation (EC) No 661/2009 UNECE Regulation No 94		C The requirements of UNECE Regulation No 94 shall apply to vehicles fitted with front airbags. Vehicles not fitted with airbags shall fulfil the requirement of item 14A of this table.
54A	Protection of occupants in the event of lateral collision	Regulation (EC) No 661/2009 UNECE Regulation No 95		C
			Head form test	The manufacturer shall supply the technical service with suitable information concerning a possible impact of the head of the dummy against the structure of the vehicle or the side glazing if made up of laminated glazing. When it is proven that such impact is likely to happen, the partial test using the head form test described in paragraph 3.1 of Annex 8 to UNECE Regulation No 95 shall be conducted and the criterion specified in paragraph 5.2.1.1 of UNECE Regulation No 95 shall be met. In agreement with the technical service, the test procedure described in Annex 4 to UNECE Regulation No 21 may be used as an alternative to the test of UNECE Regulation No 95.

Item	Subject	Regulatory act	Specific issues	Applicability and specific requirements
58	Pedestrian protection	Regulation (EC) No 78/2009	(a) Technical requirements applicable to vehicle	N/A
			(b) Frontal protection systems	X
59	Recyclability	Directive 2005/64/EC		N/A - Only Article 7 on reuse of component parts shall apply.
61	Air-conditioning systems	Directive 2006/40/EC		A Fluorinated greenhouse gases with a global warming potential higher than 150 are permitted until 31 December 2016.
62	Hydrogen system	Regulation (EC) No 79/2009		X
63	General Safety	Regulation (EC) No 661/2009		See explanatory note ⁽¹⁵⁾ of the table in Part I of Annex IV with regulatory acts for EU type-approval of vehicles produced in unlimited series.
64	Gear shift indicators	Regulation (EC) No 661/2009 Regulation (EU) No 65/2012		N/A

67	Specific components for liquefied petroleum gases (LPG) and their installation on motor vehicles	Regulation (EC) No 661/2009 UNECE Regulation No 67	(a) Components	X
			(b) Installation	A
68	Vehicle alarm systems (VAS)	Regulation (EC) No 661/2009 UNECE Regulation No 97	(a) Components	X
			(b) Installation	B
69	Electric safety	Regulation (EC) No 661/2009 UNECE Regulation No 100		B
70	Specific components for CNG and their installation on motor vehicles	Regulation (EC) No 661/2009 UNECE Regulation No 110	(a) Components	X
			(b) Installation	A
72	eCall system	Regulation (EU) 2015/758		N/A

Explanatory notes	
X	<p>Full application of the regulatory act as follows:</p> <ul style="list-style-type: none"> (a) a type-approval certificate shall be issued; (b) tests and checks shall be conducted by the technical service or the manufacturer under the conditions laid down in Articles 71 to 85; (c) a test report shall be drafted in accordance with the provisions of Annex V; (d) Conformity of Production (COP) shall be ensured.
A	<p>Application of the regulatory act as follows:</p> <ul style="list-style-type: none"> (a) all requirements of the regulatory act shall be fulfilled unless otherwise stated; (b) no type-approval certificate shall be required; (c) tests and checks shall be conducted by the technical service or the manufacturer under the conditions laid down in Articles 71 to 85; (d) a test report shall be drafted in accordance with the provisions of Annex V; (e) COP shall be ensured.
B	<p>Application of the regulatory act as follows:</p> <p>Same as for letter 'A' with the exception that the tests and checks may be performed by the manufacturer himself, subject to the agreement of the approval authority.</p>

C	<p>Application of the regulatory act as follows:</p> <ul style="list-style-type: none"> (a) only the technical requirements from the regulatory shall be fulfilled, irrespective of any transitional provision; (b) no type-approval certificate shall be required; (c) tests and checks shall be conducted by the technical service or by the manufacturer (see decisions for letter 'B'); (d) a test report shall be drafted in accordance with the provisions of Annex V; (e) COP shall be ensured.
D	<p>Same as for decisions in letters 'B' and 'C', with the exception that a statement of compliance submitted by the manufacturer is sufficient. No test report shall be required.</p> <p>The approval authority or technical service may require additional information of further evidence, if need be.</p>
N/A	<p>The regulatory act shall not apply. Compliance with one or more specific aspects included in the regulatory act may however be imposed.</p>
<p>The series of amendments of the UNECE Regulations to be used are listed in Annex IV to Regulation (EC) No 661/2009. The series of amendments adopted subsequently are accepted as an alternative.</p>	

Table 2

N₁ vehicles ³³

Item	Subject	Regulatory act	Specific issues	Applicability and specific requirements
1A	Sound level	Regulation (EU) No 540/2014		A

³³ The explanatory notes relating to Part I of Annex IV also apply to Table 2. The letters in table 2 have the same meaning as in Table 1.

2	Emissions (Euro 5 and 6) light duty vehicles/access to information	Regulation (EC) No 715/2007		A
			(a) OBD	<p>The vehicle shall be fitted with an OBD system that fulfils the requirements of Article 4(1) and (2) of Regulation (EC) No 692/2008 (the OBD system shall be designed to record at least the malfunction of the engine management system).</p> <p>The OBD-interface shall be able to communicate with commonly available diagnostic tools.</p>
			(b) In service conformity	N/A
			(c) Access to information	It is sufficient that the manufacturer provides access to vehicle repair and maintenance information in a readily accessible and prompt manner.
(d) Power measurement	<p><i>(When the vehicle manufacturer uses an engine from another manufacturer)</i></p> <p>Bench test data from the engine manufacturer are accepted provided that the engine management system is identical (i.e. having at least the same ECU).</p> <p>Power output test may be performed on a chassis dynamometer. It shall be taken into account of the power loss in the transmission.</p>			

3A	Prevention of fire risks (liquid fuel tanks)	Regulation (EC) No 661/2009	(a) Liquid fuel tanks	B
		UNECE Regulation No 34	(b) Installation in vehicle	B
3B	Rear underrun protective devices (RUPDs) and their installation; rear underrun protection (RUP)	Regulation (EC) No 661/2009 UNECE Regulation No 58		B
4A	Space for mounting and fixing rear registration plates	Regulation (EC) No 661/2009 Regulation (EU) No 1003/2010		B

Item	Subject	Regulatory act	Specific issues	Applicability and specific requirements
5A	Steering equipment	Regulation (EC) No 661/2009 UNECE Regulation No 79		C
			(a) Mechanical systems	The provisions of paragraph 5 of UNECE Regulation No 79.01 shall apply. All tests prescribed in paragraph 6.2 of UNECE Regulation No 79 shall be performed and the requirements of paragraph 6.1 of UNECE Regulation No 79 shall apply.
			(b) Complex electronic vehicle control system	All the requirements of Annex 6 of UNECE Regulation No 79 shall apply. Compliance with these requirements may only be checked by a technical service.
6A	Door latches and door retention components	Regulation (EC) No 661/2009 UNECE Regulation No 11		C
			(a) General requirements (Paragraph 5 of UNECE Regulation No 11)	All requirements shall apply.
			(b) Performance requirements (Paragraph 6 of UNECE Regulation No 11)	Only the requirements of paragraph 6.1.5.4 and paragraph 6.3 of UNECE Regulation No 11 shall apply.

7A	Audible warning devices and signals	Regulation (EC) No 661/2009	(a) Components	X
		UNECE Regulation No 28	(b) Installation on vehicle	B
8A	Devices for indirect vision and their installation	Regulation (EC) No 661/2009	(a) Components	X
		UNECE Regulation No 46	(b) Installation on vehicle	B
9A	Braking of vehicles and trailers	Regulation (EC) No 661/2009	(a) design and test requirements	A
		UNECE Regulation No 13.	(b) ESC	The fitting of ESC shall not be required. If fitted, it shall comply with the requirements of UNECE Regulation No 13.

Item	Subject	Regulatory act	Specific issues	Applicability and specific requirements
9B	Braking of passenger cars	Regulation (EC) No 661/2009 UNECE Regulation No 13-H	(a) Design and test requirements	A
			(b) Electronic stability control (ESC) and brake assist systems(BAS)	The fitting of BAS and ESC shall not be required. If fitted, they shall comply with the requirements of UNECE Regulation No 13-H.
10A	Electromagnetic compatibility	Regulation (EC) No 661/2009 UNECE Regulation No 10		B
13A	Protection of motor vehicles against unauthorised use	Regulation (EC) No 661/2009 UNECE Regulation No 116		A The provisions of paragraph 8.3.1.1.1. of UNECE Regulation No 116 may be applied instead of paragraph 8.3.1.1.2. of that Regulation regardless of the type of powertrain

14A	Protection of the driver against the steering mechanism in the event of impact	Regulation (EC) No 661/2009 UNECE Regulation No 12		C
			(a) Barrier impact test	A test shall be required.
			(b) Body block impact test against steering wheel	Not required if the steering wheel is fitted with an airbag.
			(c) Head form test	Not required if the steering wheel is fitted with an airbag.
15A	Seats, their anchorages and any head restraints	Regulation (EC) No 661/2009 UNECE Regulation No 17		B
17A	Vehicle access and manoeuvrability	Regulation (EC) No 661/2009 Regulation (EU) No 130/2012		D
17B	Speedometer equipment including its installation	Regulation (EC) No 661/2009 UNECE Regulation No 39		B
18A	Manufacturer's statutory plate and vehicle identification number	Regulation (EC) No 661/2009 Regulation (EU) No 19/2011		B

Item	Subject	Regulatory act	Specific issues	Applicability and specific requirements
19A	Safety-belt anchorages, Isofix anchorages systems and Isofix top tether anchorages	Regulation (EC) No 661/2009 UNECE Regulation No 14		B
20A	Installation of lighting and light-signalling devices on motor vehicles	Regulation (EC) No 661/2009 UNECE Regulation No 48		B DRLs shall be fitted to a new type of vehicle.
21A	Retro-reflecting devices for power-driven vehicles and their trailers	Regulation (EC) No 661/2009 UNECE Regulation No 3		X
22A	Front and rear position lamps, stop-lamps and end-outline marker lamps for motor vehicles and their trailers	Regulation (EC) No 661/2009 UNECE Regulation No 7		X

22B	Daytime running lamps for power-driven vehicles	Regulation (EC) No 661/2009 UNECE Regulation No 87		X
22C	Side-marker lamps for motor vehicles and their trailers	Regulation (EC) No 661/2009 UNECE Regulation No 91		X
23A	Direction indicators for power-driven vehicles and their trailers	Regulation (EC) No 661/2009 UNECE Regulation No 6		X
24A	Illumination of rear-registration plates of power-driven vehicles and their trailers	Regulation (EC) No 661/2009 UNECE Regulation No 4		X
25A	Power-driven vehicle's sealed-beam headlamps (SB) emitting an European asymmetrical passing beam or a driving beam or both	Regulation (EC) No 661/2009 UNECE Regulation No 31		X

Item	Subject	Regulatory act	Specific issues	Applicability and specific requirements
25B	Filament lamps for use in approved lamp units of power-driven vehicles and their trailers	Regulation (EC) No 661/2009 UNECE Regulation No 37		X
25C	Motor vehicle headlamps equipped with gas-discharge light sources	Regulation (EC) No 661/2009 UNECE Regulation No 98		X
25D	Gas-discharge light sources for use in approved gas-discharge lamp units of power-driven vehicles	Regulation (EC) No 661/2009 UNECE Regulation No 99		X
25E	Motor vehicle headlamps emitting an asymmetrical passing beam or a driving beam or both and equipped with filament lamps and/or LED modules	Regulation (EC) No 661/2009 UNECE Regulation No 112		X

25F	Adaptive front-lighting systems (AFS) for motor vehicles	Regulation (EC) No 661/2009 UNECE Regulation No 123		X
26A	Power-driven vehicle front fog lamps	Regulation (EC) No 661/2009 UNECE Regulation No 19		X
27A	Towing device	Regulation (EC) No 661/2009 Regulation (EU) No 1005/2010		B
28A	Rear fog lamps for power-driven vehicles and their trailers	Regulation (EC) No 661/2009 UNECE Regulation No 38		X
29A	Reversing lights for power-driven vehicles and their trailers	Regulation (EC) No 661/2009 UNECE Regulation No 23		X
30A	Parking lamps for power-driven vehicles	Regulation (EC) No 661/2009 UNECE Regulation No 77		X

Item	Subject	Regulatory act	Specific issues	Applicability and specific requirements
31A	Safety-belts, restraint systems, child restraint systems and Isofix child restraint systems	Regulation (EC) No 661/2009 UNECE Regulation No 16	(a) Components	X
			(b) Installation requirements	B
33A	Location and identification of hand controls, tell-tales and indicators	Regulation (EC) No 661/2009 UNECE Regulation No 121		A
34A	Windscreen defrosting and demisting systems	Regulation (EC) No 661/2009 Regulation (EU) No 672/2010		N/A The vehicle shall be fitted with a suitable windscreen defrosting and demisting system.
35A	Windscreen wiper and washer systems	Regulation (EC) No 661/2009 Regulation (EU) No 1008/2010		N/A The vehicle shall be fitted with a suitable windscreen wiper and washer system.
36A	Heating system	Regulation (EC) No 661/2009 UNECE Regulation No 122		C The fitting of a heating system shall not be required.
			(a) All heating systems	The requirements of paragraphs 5.3 and 6 of UNECE Regulation No 122 shall apply.
			(b) LPG heating systems	The requirements of Annex 8 to UNECE Regulation No 122 shall apply.

41A	Emissions (Euro VI) heavy duty vehicles/access to information	Regulation (EC) No 595/2009		A With the exception of the set of requirements relating to OBDS and access to information.
			Power measurement	<i>(When the vehicle manufacturer uses an engine from another manufacturer)</i> Bench test data from the engine manufacturer are accepted provided that the engine management system is identical (i.e. having at least the same ECU). Power output test may be performed on a chassis dynamometer. It shall be taken into account of the power loss in the transmission.
43A	Spray suppression systems	Regulation (EC) No 661/2009 Regulation (EU) No 109/2011		B

Item	Subject	Regulatory act	Specific issues	Applicability and specific requirements
45A	Safety glazing materials and their installation on vehicles	Regulation (EC) No 661/2009	(a) Components	X
		UNECE Regulation No 43	(b) Installation	B
46	Tyres	Directive 92/23/EEC	Components	X
46A	Installation of tyres	Regulation (EC) No 661/2009 Regulation (EU) No 458/2011		B Dates for progressive application shall be those set out in Article 13 of Regulation (EC) No 661/2009.
46B	Pneumatic tyres for motor vehicles and their trailers (Class C1)	Regulation (EC) No 661/2009 UNECE Regulation No 30	Components	X
46C	Pneumatic tyres for commercial vehicles and their trailers (Classes C2 and C3)	Regulation (EC) No 661/2009 UNECE Regulation No 54	Components	X

46D	Tyre rolling sound emissions, adhesion on wet surfaces and rolling resistance (Classes C1, C2 and C3)	Regulation (EC) No 661/2009 UNECE Regulation No 117	Components	X
46E	Temporary-use spare unit, run-flat tyres/system and tyre pressure monitoring system	Regulation (EC) No 661/2009 UNECE Regulation No 64	Components	X
			Fitting of a tyre-pressure monitoring system	B The fitting of a TPMS shall not be required
48A	Masses and dimensions	Regulation (EC) No 661/2009 Regulation (EU) No 1230/2012		B
			Hill start test at maximum combination mass	The hill start test at maximum combination mass described in point 5.1 of Part A of Annex 1 to Regulation (EU) No 1230/2012 may be waived at the request of the manufacturer.

Item	Subject	Regulatory act	Specific issues	Applicability and specific requirements
49A	Commercial vehicles with regards to their external projections forward of the cab's rear panel	Regulation (EC) No 661/2009 UNECE Regulation No 61		C
			(a) General specifications	The requirements of paragraph 5 of UNECE Regulation No 61 shall apply
			(b) Particular specifications	The requirements of paragraph 6 of UNECE Regulation No 61 shall apply.
50A	Mechanical coupling components of combinations of vehicles	Regulation (EC) No 661/2009 UNECE Regulation No 55	(a) Components	X
			(b) Installation	B
54A	Protection of occupants in the event of lateral collision	Regulation (EC) No 661/2009 UNECE Regulation No 95	C	C
			Head form test	<p>The manufacturer shall supply the technical service with suitable information concerning a possible impact of the head of the dummy against the structure of the vehicle or the side glazing, if made up of laminated glazing.</p> <p>When such impact is proven likely to happen, then the partial test using the head form test described in paragraph 3.1 of Annex 8 to UNECE Regulation No 95 shall be conducted and the criterion specified in paragraph 5.2.1.1 of UNECE Regulation No 95 shall be met.</p> <p>In agreement with the technical service, the test procedure described in Annex 4 to UNECE Regulation No 21 may be used as an alternative to the test of UNECE Regulation No 95 mentioned above.</p>

56A	Vehicles for the carriage of dangerous goods	Regulation (EC) No 661/2009 UNECE Regulation No 105		A
58	Pedestrian protection	Regulation (EC) No 78/2009	(a) Technical requirements applicable to a vehicle	N/A
			(b) Frontal protection systems	X
59	Recyclability	Directive 2005/64/EC		N/A Only Article 7 on reuse of component parts shall apply.

Item	Subject	Regulatory act	Specific issues	Applicability and specific requirements
61	Air-conditioning systems	Directive 2006/40/EC		B Fluorinated greenhouse gases with a global warming potential higher than 150 are permitted until 31 December 2016.
62	Hydrogen system	Regulation (EC) No 79/2009		X
63	General Safety	Regulation (EC) No 661/2009		See explanatory note ⁽¹⁵⁾ of the table in Part I of Annex IV with regulatory acts for EU type-approval of vehicles produced in unlimited series.
67	Specific components for liquefied petroleum gases (LPG) and their installation on motor vehicles	Regulation (EC) No 661/2009 UNECE Regulation No 67	(a) Components	X
			(b) Installation	A
68	Vehicle alarm systems (VAS)	Regulation (EC) No 661/2009 UNECE Regulation No 97	(a) Components	X
			(b) Installation	B

69	Electric safety	Regulation (EC) No 661/2009 UNECE Regulation No 100		B
70	Specific components for CNG and their installation on motor vehicles	Regulation (EC) No 661/2009 UNECE Regulation No 110	(a) Components	X
			(b) Installation	A
71	Cab strength	Regulation (EC) No 661/2009 UNECE Regulation No 29		C
72	eCall System	Regulation (EU) 2015/758		N/A'

Appendix 2

Requirements for EU individual vehicle approval pursuant to Article 42

1. APPLICATION

For the purpose of application of this appendix, a vehicle is deemed to be new where:

- (a) it has never been registered previously; or
- (b) it has been registered for less than 6 months at the time of the application for individual vehicle approval.

A vehicle shall be considered registered where it has obtained a permanent, temporary or short-term administrative authorisation for entry into service in road traffic, involving its identification and the issuing of a registration number ⁽¹⁾.

- (¹) In the absence of a registration document, the competent authority may refer to available documented evidence of date of manufacture or documented evidence of first purchase.

1. ADMINISTRATIVE PROVISIONS

1.1. Categorisation of the vehicle

Vehicles shall be categorised according to the criteria set out in Annex II as follows:

- (a) the actual number of seating positions shall be taken into consideration; and
- (b) the technically maximum permissible laden mass shall be the maximum mass stated by the manufacturer in the country of origin and available in his official documentation.

Where it is not possible to easily determine the vehicle category because of the design of the bodywork, the conditions set out in Annex II shall apply.

1.2. Application for individual vehicle approval

- (a) The applicant shall submit an application to the approval authority accompanied by all relevant documentation necessary for the operation of the approval procedure.

Where the submitted documentation is incomplete, falsified or forged the application for approval shall be rejected.

- (b) Only one application for a particular vehicle may be submitted in only one Member State. The approval authority may require from the applicant a written commitment that only one application will be submitted in the Member State of the approval authority.

By a particular vehicle, it shall be understood a physical vehicle the vehicle identification number of which is clearly identified.

However, any applicant may apply for EU individual vehicle approval in another Member State in respect of another particular vehicle with technical characteristics identical or similar to the one that has been granted an EU individual vehicle approval.

- (c) The model of the application form and the layout of the file shall be laid down by the approval authority.

The particulars of the vehicle requested may only consist in an appropriate selection of the information included in Annex I.

- (d) The technical requirements to be complied with are those laid down in section 4.

The technical requirements shall be those applicable to new vehicles belonging to a type of vehicle currently in production, in relation to the date of the submission of the application.

- (e) With respect to the tests required in the regulatory acts listed in this Annex, the applicant shall supply a statement of compliance with recognised international standards or regulations. The statement in question may only be issued by the vehicle manufacturer.

‘Statement of compliance’ shall mean a statement issued by the office or department within the manufacturer’s organisation that is duly authorised by the management to fully engage the legal responsibility of the manufacturer with respect to the design and the construction of a vehicle.

The regulatory acts for which such a statement has to be supplied shall be those referred to in section 4.

Where a statement of compliance gives rise to uncertainty, the applicant may be required to obtain from the manufacturer a piece of evidence, including a test report, in order to corroborate the manufacturer’s statement.

1.3. Technical services entrusted with individual vehicle approvals

- (a) The technical services entrusted with individual vehicle approvals shall be of category A as referred to in Article 72(1).
- (b) By way of derogation from the requirement to demonstrate their compliance with the standards listed in Appendix 1 to Annex V, technical services shall comply with the following standards:
 - (i) EN ISO/IEC 17025:2005 when they perform tests themselves;
 - (ii) EN ISO/IEC 17020:2012 when they check compliance of the vehicle with the requirements included in this Appendix.
- (c) Where specific tests requiring specific skills have to be conducted at the request of the applicant, they shall be conducted by one of the technical services notified to the Commission at the choice of the applicant.

1.4. Test reports

- (a) Test reports shall be drafted in accordance with paragraph 5.10.2 of Standard EN ISO/IEC 17025:2005.
- (b) Test reports shall be drafted in one of the languages of the Union determined by the approval authority.

Where in application of point 1.3(c) a test report has been issued in a Member State other than the one entrusted with the individual vehicle approval, the approval authority may require that the applicant submits a true translation of the test report.

- (c) Test reports shall include a description of the vehicle tested, including its identification. The parts that play a significant role with regard to the results of the tests shall be described and their identification number reported.
- (d) At the request of an applicant, a test report delivered for a system related to a particular vehicle may be presented repeatedly either by the same or another applicant for the purposes of individual approval of another vehicle.

In such a case, the approval authority shall ensure that the technical characteristics of the vehicle are properly inspected against the test report.

Inspection of the vehicle and the documentation accompanying the test report shall demonstrate that the vehicle for which an individual approval is sought has the same characteristics as the vehicle described in the report.

- (e) Only authenticated copies of a test report may be submitted.
- (f) Test reports referred to in point 1.4(d) do not include the reports drawn up in order to grant the individual vehicle approval.
- 1.5. In the individual vehicle approval procedure each particular vehicle shall be inspected physically by the technical service.
- No exemption to this principle shall be permitted.
- 1.6. Where the approval authority is satisfied that the vehicle meets the technical requirements specified in this Appendix and conforms to the description included in the application, it shall grant approval in accordance with Article 42.
- 1.7. The certificate of approval shall be drafted according to Model D as laid down in Annex VI.
- 1.8. The approval authority shall keep record of all approvals granted under Article 42.

2. REVIEW OF THE TECHNICAL REQUIREMENTS

The list of the technical requirements included in section 3 shall be regularly reviewed in order to take account of the results of the harmonisation work in progress at the World Forum for Harmonization of Vehicle Regulations (WP.29) in Geneva and legislative developments in the third countries.

3. TECHNICAL REQUIREMENTS

Part I: Vehicles belonging to category M₁

Item	Regulatory act reference	Alternative requirements
1	Council Directive 70/157/EEC ³⁴ (Permissible sound level)	<i>Drive-by test</i> (a) A test shall be conducted in accordance with the 'Method A' referred to in Annex 3 to UNECE Regulation No 51. Limits are those specified in point 2.1 of Annex I to Directive 70/157/EEC. 1 decibel in addition to the permitted limits shall be allowed. (b) The test track shall comply with Annex 8 to UNECE Regulation No 51. A test track having different specifications may be used under the condition that correlation tests have been conducted by the technical service. A correction factor shall be applied if necessary. (c) Exhaust systems containing fibrous materials need not be conditioned as prescribed in Annex 5 to UNECE Regulation No 51. <i>Stationary test</i> A test shall be conducted in accordance with paragraph 3.2 of Annex 3 to UNECE Regulation No 51.

³⁴ Council Directive of 6 February 1970 on the approximation of the laws of the Member States relating to the permissible sound level and the exhaust system of motor vehicles (OJ L 42, 23.2.1970, p. 16).

2a	<p>Regulation (EC) No 715/2007 (Emissions Euro 5 and 6 light duty vehicles/access to information)</p>	<p><i>Tailpipe emissions</i></p> <p>(a) A type I test shall be conducted in accordance with Annex III to Regulation (EC) No 692/2008 using the deterioration factors set out in point 1.4 of Annex VII to Regulation (EC) No 692/2008. The limits to be applied shall be those specified in Table I and Table II in Annex I to Regulation (EC) No 715/2007.</p> <p>(b) The vehicle shall not be required to exhibit 3 000 km as mentioned in paragraph 3.1.1 of Annex 4 to UNECE Regulation No 83.</p> <p>(c) The fuel to be used for the test shall be the reference fuel as prescribed in Annex IX to Regulation (EC) No 692/2008.</p> <p>(d) The dynamometer shall be set up in accordance with the technical requirements set out in paragraph 3.2 of Annex 4 to UNECE Regulation No 83.</p> <p>(e) The test referred to in point (a) shall not be conducted where it can be shown that the vehicle complies with the California Code Regulations referred to in point 2.1.1 of Annex I to Regulation (EC) No 692/2008.</p> <p><i>Evaporative emissions</i></p> <p>For petrol-fuelled engines, the presence of an evaporate emissions control system shall be required (e.g. a charcoal canister).</p> <p><i>Crankcase emissions</i></p> <p>The presence of a device for recycling crankcase gases shall be required.</p> <p><i>OBD</i></p> <p>(a) The vehicle shall be fitted with an OBD system.</p> <p>(b) OBD-interface must be able to communicate with common diagnostic tools used for periodic technical inspections.</p>
----	---	---

	<p><i>Smoke opacity</i></p> <p>(a) Vehicles equipped with a diesel-fuelled engine shall be tested in accordance with the tests methods referred to in Appendix 2 to Annex IV to Regulation (EC) No 692/2008.</p> <p>(b) The corrected value of the absorption coefficient shall be affixed conspicuously and in a readily accessible place.</p> <p><i>CO₂ emissions and fuel consumption</i></p> <p>(a) A test shall be conducted in accordance with Annex XII to Regulation (EC) No 692/2008.</p> <p>(b) The vehicle shall not be required to exhibit 3 000 km as requested in paragraph 3.1.1 of Annex 4 to UNECE Regulation No 83.</p> <p>(c) Where the vehicle complies with the California Code Regulations referred to in point 2.1.1 of Annex I to Regulation (EC) No 692/2008 and therefore no test of tailpipe emissions is required to be performed, Member States shall calculate CO₂ emissions and fuel consumption with the formula laid down in the explanatory notes ^(b) and ^(c).</p> <p><i>Access to information</i></p> <p>The provisions regarding access to information shall not apply.</p> <p><i>Power measurement</i></p> <p>(a) The applicant shall submit a statement from the manufacturer stating the maximum engine power output in kW as well as the corresponding engine speed in revolutions per minute.</p> <p>(b) An engine power output curve providing the same information may alternatively be provided by the applicant.</p>
--	---

3	<p>UNECE Regulation No 34 (Fuel tanks — Rear protective devices)</p>	<p><i>Fuel tanks</i></p> <p>(a) Fuel tanks shall comply with paragraph 5 of UNECE Regulation No 34 with the exception of paragraphs 5.1, 5.2 and 5.12. In particular, they shall comply with paragraphs 5.9 and 5.9.1 but no dripping test shall be conducted.</p> <p>(b) LPG or CNG tanks shall be type-approved in accordance with UNECE Regulation No 67, series of amendments 01, or Regulation No 110 (^a), respectively.</p> <p><i>Specific provisions for fuel tanks made of a plastic material</i></p> <p>The applicant shall submit a statement from the manufacturer establishing that the fuel tank on the particular vehicle, the Vehicle Identification Number (VIN) of which has to be specified, complies either with at least one of the following:</p> <ul style="list-style-type: none"> — FMVSS No 301 (Fuel system integrity), or — Annex 5 to UNECE Regulation 34. <p><i>Rear protective device</i></p> <p>The rear part of the vehicle shall be constructed in accordance with paragraphs 8 and 9 of UNECE Regulation No 34.</p>
3B	<p>UNECE Regulation No 58 (rear underrun protection)</p>	<p>The rear part of the vehicle shall be constructed in accordance with paragraph 2 UNECE Regulation No 58. It is sufficient that the requirements set out in paragraph 2.3 are fulfilled.</p>
4	<p>Regulation (EU) No 1003/2010 (Rear registration plate space)</p>	<p>Space, inclination, angles for visibility and position of the registration plate shall comply with Regulation (EU) No 1003/2010.</p>

5	<p>UNECE Regulation No 79 (Steering effort)</p>	<p><i>Mechanical systems</i></p> <p>(a) The steering mechanism shall be built as to self-centre. In order to check compliance with this provision, a test shall be conducted in accordance with paragraphs 6.1.2 and 6.2.1 of UNECE Regulation No 79.</p> <p>(b) The failure of the power steering equipment shall not lead to a complete loss of control of the vehicle.</p> <p><i>Complex electronic vehicle control system ('Drive-by wire' devices)</i></p> <p>Complex electronic control system shall be permitted only if they comply with Annex 6 to UNECE Regulation No 79.</p>
6	<p>UNECE Regulation No 11 (Door latches and hinges)</p>	<p>Compliance with paragraph 6.1.5.4 of UNECE Regulation No 11.</p>
7	<p>UNECE Regulation No 28 (Audible warning)</p>	<p><i>Components</i></p> <p>The audible warning devices are not required to be type-approved in accordance with UNECE Regulation No 28. However, they shall emit a continuous sound as required in paragraph 6.1.1 of UNECE Regulation No 28.</p> <p><i>Installation on vehicle</i></p> <p>(a) A test shall be conducted in accordance with paragraph 6.2 of UNECE Regulation No 28.</p> <p>(b) The maximum sound pressure level shall be in accordance with paragraph 6.2.7.</p>

8	<p>UNECE Regulation No 46 (Indirect vision devices)</p>	<p><i>Components</i></p> <p>(a) The vehicle shall be fitted with the rear-view mirrors prescribed in paragraph 15.2 of UNECE Regulation No 46.</p> <p>(b) They are not required to be type-approved in accordance with UNECE Regulation No 46.</p> <p>(c) The radii of curvature of the mirrors shall not cause significant image distortions. At the discretion of the technical service, the radii of curvature shall be checked in accordance with the method described in Annex 7 to UNECE Regulation No 46. The radii of curvature shall not be less than those required by paragraph 6.1.2.2.4. of UNECE Regulation No 46.</p> <p><i>Installation on vehicle</i></p> <p>Measurement shall be conducted in order to ensure that the fields of vision comply either with paragraph 15.2.4. of UNECE Regulation No 46 or with section 5 of Annex III to Directive 71/127/EEC.</p>
---	--	--

9	<p>UNECE Regulation No 13-H (Braking)</p>	<p><i>General provisions</i></p> <p>(a) The braking system shall be built in accordance with paragraph 5 of UNECE Regulation No 13-H.</p> <p>(b) Vehicles shall be fitted with an electronic antilock braking system acting on all wheels.</p> <p>(c) The performances of the braking system shall comply with Annex III to UNECE Regulation No 13-H.</p> <p>(d) For those purposes, road tests shall be conducted on a track the surface of which possesses high adhesion. The test on the parking brake shall be conducted on a 18 % gradient (up and down).</p> <p>Only those tests mentioned under the headings "Service brake" and "Parking brake" below shall be conducted. In each case, the vehicle shall be in fully laden conditions.</p> <p>(e) The road test referred to in point (d) shall not be conducted where the applicant can submit a statement from the manufacturer establishing that the vehicle complies either with UNECE Regulation No 13-H, including supplement 5, or with FMVSS No 135.</p> <p><i>Service brake</i></p> <p>(a) A 'Type 0' test as prescribed in paragraphs 1.4.2 and 1.4.3 of Annex 3 to UNECE Regulation No 13-H shall be conducted.</p> <p>(b) In addition, a 'Type I' test as prescribed in paragraph 1.5 of Annex 3 to UNECE Regulation No 13-H shall be conducted.</p> <p><i>Parking brake</i></p> <p>A test shall be conducted in accordance with paragraph 2.3 of Annex 3 to UNECE Regulation No 13-H.</p>
---	---	--

10	<p>UNECE Regulation No 10</p> <p>(Radio interference (electromagnetic compatibility))</p>	<p><i>Components</i></p> <p>(a) Electrical/electronic sub-assemblies are not required to be type-approved in accordance with UNECE Regulation No 10.</p> <p>(b) However, electric/electronic devices retrofitted shall comply with UNECE Regulation No 10.</p> <p><i>Emitted electromagnetic radiations</i></p> <p>The applicant shall submit a statement from the manufacturer establishing that the vehicle complies with UNECE Regulation No 10 or with the following alternative standards:</p> <ul style="list-style-type: none"> — Broadband electromagnetic radiation: CISPR 12 or SAE J551-2, or — Narrowband electromagnetic radiation: CISPR 12 (off-board) or 25 (in-board) or SAE J551-4 and SAE J1113-41. <p><i>Immunity tests</i></p> <p>Immunity test shall be waived.</p>
----	---	---

12	<p>UNECE Regulation No 21</p> <p>(Interior fittings)</p>	<p><i>Interior arrangement</i></p> <p>(a) With respect to the requirements on energy absorption, the vehicle shall be deemed to comply with UNECE Regulation No 21 if the vehicle is fitted with at least two front airbags, one inserted into the steering wheel and the other into the dashboard.</p> <p>(b) Where the vehicle is fitted with only one front air bag inserted in the steering wheel, the dashboard shall be made up of energy absorbing materials.</p> <p>(c) The technical service shall check that there are no sharp edges in the zones defined in paragraphs 5.1 to 5.7 of UNECE Regulation No 21.</p> <p><i>Electrical controls</i></p> <p>(a) Power-operated windows, roof-panel systems and partitioning systems shall be tested in accordance with paragraph 5.8 of UNECE Regulation No 21.</p> <p>The sensitivity of auto-reverse systems referred to in paragraph 5.8.3 may diverge from the requirements set out in paragraph 5.8.3.1.1 of UNECE Regulation No 21.</p> <p>(b) Electric windows which cannot be closed when the ignition is off shall be exempt from the requirements concerning auto-reverse systems.</p>
----	--	--

13	UNECE Regulation No 18 (Anti-theft and immobiliser)	<p>(a) In order to prevent unauthorised use, the vehicle shall be fitted with:</p> <ul style="list-style-type: none"> — a locking device as defined in paragraph 2.3 of UNECE Regulation No 18, and — an immobiliser which meets the technical requirements of paragraph 5 of UNECE Regulation No 18; <p>(b) If, in accordance with point (a), an immobiliser has to be retrofitted, it shall be of an approved type in accordance with UNECE Regulations No 18, No 97, or No 116.</p>
14	UNECE Regulation No 12 (Protective steering)	<p>(a) The applicant shall submit a statement from the manufacturer establishing that the particular vehicle, the VIN of which has to be specified, complies with at least one of the following:</p> <ul style="list-style-type: none"> — UNECE Regulation No 12, — FMVSS No 203 (Impact protection for the driver from the steering control system) including FMVSS No 204 (Steering control rearward displacement), — Article 11 of JSRRV. <p>(b) A test in accordance with Annex 3 to UNECE Regulation No 12 may be conducted on a production vehicle at the request of the applicant.</p> <p>The test shall be conducted by a technical service that has been designated for carrying out this test. A detailed report shall be issued by that technical service to the applicant.</p>

15	<p>UNECE Regulation No 17 (Seat strength — head restraints)</p>	<p><i>Seats, seat anchorages and adjustment systems</i></p> <p>The applicant shall submit a statement from the manufacturer establishing that the particular vehicle, the VIN of which has to be specified, complies with at least one of the following:</p> <ul style="list-style-type: none"> — UNECE Regulation No 17; or — FMVSS No 207 (Seating systems). <p><i>Head restraints</i></p> <p>(a) Where the statement is based on FMVSS No 207, the head restraints shall fulfil, in addition, the requirements of paragraph 5 and Annex 4 to UNECE Regulation No 17.</p> <p>(b) Only the tests described in paragraphs 5.12, 6.5, 6.6 and 6.7 of UNECE Regulation No 17 shall be conducted.</p> <p>(c) In the other event, the applicant shall submit a statement from the manufacturer establishing that the particular vehicle, the VIN of which has to be specified, complies with FMVSS No 202a (Head restraints).</p>
16	<p>UNECE Regulation No 17 (Exterior projections)</p>	<p>(a) The external surface of the bodywork shall comply with the general requirements included in paragraph 5 of UNECE Regulation No 17.</p> <p>(b) At the discretion of the technical service the provisions referred to in paragraphs 6.1, 6.5, 6.6, 6.7, 6.8 and 6.11 of UNECE Regulation No 17 shall be checked.</p>

17	<p>UNECE Regulation No 39 (Speedometer — reverse gear)</p>	<p><i>Speedometer equipment</i></p> <p>(a) The dial shall comply with paragraphs 5.1 to 5.1.4 of UNECE Regulation No 39.</p> <p>(b) Where the technical service wants to verify that the speedometer is calibrated with sufficient accuracy, it may require the tests prescribed in paragraph 5.2 of UNECE Regulation No 39 to be conducted.</p> <p><i>Reverse gear</i></p> <p>The gear mechanism shall include a reverse gear.</p>
18	<p>Regulation (EU) No 19/2011 (Statutory plates)</p>	<p><i>Vehicle identification number</i></p> <p>(a) The vehicle shall be fitted with a vehicle identification number comprising a minimum of 8 and a maximum of 17 characters. Vehicle identification number comprising 17 characters shall fulfil the requirements set out in Standards ISO 3779:1983 and 3780:1983.</p> <p>(b) The vehicle identification number shall be located in a clearly visible and accessible position in such a way as it cannot be obliterated or deteriorate.</p> <p>(c) Where no vehicle identification number is stamped in the chassis or in the body, a Member State may require the applicant that the VIN is retrofitted in application of its national law. In such a case, the competent authority of that Member State shall supervise the operation.</p> <p><i>Statutory plate</i></p> <p>The vehicle shall be fitted with an identification plate affixed by the vehicle manufacturer.</p> <p>No additional plate shall be requested after the approval by the approval authority has been granted.</p>

19	UNECE Regulation No 14 (Seat belt anchorages)	<p>The applicant shall submit a statement from the manufacturer establishing that the particular vehicle, the VIN of which has to be specified, complies with at least one of the following:</p> <ul style="list-style-type: none"> — UNECE Regulation No 14; — FMVSS No 210 (Seat belt assembly anchorages), or — Article 22-3 of JSRRV.
20	UNECE Regulation No 48 (Installation of lighting and light signalling devices)	<p>(a) The lighting installation shall meet the requirements of UNECE Regulation No 48, series of amendments 03, with the exception of the requirements of Annexes 5 and 6 to that Regulation.</p> <p>(b) No exemption shall be permitted in respect of the number, the essential design characteristics, the electrical connections, and the colour of light emitted or retro-reflected of the lights and signalling devices referred to in items 21 to 26 and in items 28 to 30.</p> <p>(c) Lights and signalling devices that, for the purpose of fulfilling the requirements of point (a) must be retrofitted shall bear an 'EU' type-approval mark.</p> <p>(d) Lamps fitted with gas-discharged light source are only permitted in conjunction with the installation of headlamp cleaning device and an automatic headlamp-levelling device where appropriate.</p> <p>(e) Headlamp dipped-beams shall be adapted to the direction of traffic legally in force in the country where the vehicle is granted approval.</p>

21	UNECE Regulation No 3 (Retro reflectors)	Where necessary, two additional retro reflectors bearing an 'EC' approval mark shall be added at the rear, the position of which shall comply with UNECE Regulation No 48.
22	UNECE Regulations No 7, No 87 and No 91 (End-outline, front position (side), rear-position (side), stop, side marker, daytime running lamps)	The requirements set out in the UNECE Regulations No 7, No 87 and No 91 shall not apply. However, the correct functioning of the lights shall be checked by the technical service.
23	UNECE Regulation No 6 (Direction indicators)	The requirements set out in UNECE Regulation No 6 shall not apply. However, the correct functioning of the lights shall be checked by the technical service.
24	UNECE Regulation No 4 (Rear registration plate lamps)	The requirements set out in UNECE Regulation No 4 shall not apply. However, the correct functioning of the lights shall be checked by the technical service.
25	UNECE Regulations No 98, No 112 and No 123 (Headlamps (including bulbs))	(a) The illumination produced by the passing beam of the headlamps fitted to the vehicle shall be checked under paragraph 6 of UNECE Regulation No 112 concerning headlamps emitting an asymmetrical passing beam. The tolerances included in Annex 5 to that Regulation may be referred to for that purpose. (b) The same requirement shall be fulfilled for the passing beam of headlamps covered by UNECE Regulation No 98 or No 123.
26	UNECE Regulation No 19 (Front fog lamps)	The requirements set out in UNECE Regulation No 19 shall not apply. However, the correct functioning of the lights if fitted shall be checked by the technical service.

27	Regulation (EU) No 1005/2010 (Towing hooks)	The requirements set out in Regulation (EU) No 1005/2010 shall not apply.
28	UNECE Regulation No 38 (Rear fog lamps)	The requirements set out in UNECE Regulation No 38 shall not apply. However, the correct functioning of the lights shall be checked by the technical service.
29	UNECE Regulation No 23 (Reversing lamps)	The requirements set out in UNECE Regulation No 23 shall not apply. However, the correct functioning of the lights if fitted shall be checked by the technical service.
30	UNECE Regulation No 77 (Parking lamps)	The requirements set out in UNECE Regulation No 77 shall not apply. However, the correct functioning of the lights if fitted shall be checked by the technical service.
31	UNECE Regulation No 16 (Seat belts and restraint systems)	<p><i>Components</i></p> <ul style="list-style-type: none"> (a) Seat belts shall not be required to be type-approved in accordance with UNECE Regulation No 16. (b) However, each seat belt shall bear an identification label. (c) The indications on the label shall be consistent with the decision concerning seat belt anchorages (Re: entry 19). <p><i>Installation requirements</i></p> <ul style="list-style-type: none"> (a) The vehicle shall be fitted with seat belts in accordance with the requirements set out in Annex XVI to UNECE Regulation No 16. (b) Where a number of seat belts have to be retrofitted in accordance with point (a), they shall be of an approved type in accordance with UNECE Regulation No 16.

32	UNECE Regulation No 125 (Forward vision)	<p>(a) No obstruction in the 180° forward field of vision of the driver as defined in paragraph 5.1.3 of UNECE Regulation No 125 shall be permitted.</p> <p>(b) By derogation from point (a), the ‘A pillars’ and the equipment listed in paragraph 5.1.3 of UNECE Regulation No 125 shall not be considered as obstruction.</p> <p>(c) The number of ‘A pillars’ shall not exceed 2.</p>
33	UNECE Regulation No 121 (Identification of controls, tell-tales and indicators)	<p>(a) The symbols including the colour of their corresponding tell-tales the presence of which is mandatory by virtue of UNECE Regulation No 121 shall comply with that UNECE Regulation.</p> <p>(b) Where this is not the case, the technical service shall verify that the symbols, tell-tales and indicators fitted to the vehicle provide the driver with comprehensible information about the operation of the controls in question.</p>
34	Regulation (EU) No 672/2010 (Defrost/Demist)	<p>The vehicle shall be equipped with adequate windscreen defrosting and windscreen demisting devices.</p> <p>A windscreen defrosting device which complies as a minimum with point 1.1.1 of Annex II to Regulation (EU) No 672/2010 shall be deemed ‘adequate’.</p> <p>A windscreen demisting device which complies as a minimum with point 1.2.1 of Annex II to Regulation (EU) No 672/2010 shall be deemed ‘adequate’.</p>

35	Regulation (EU) No 1008/2010 (Wash/Wipe)	<p>The vehicle shall be equipped with adequate windscreen washing and windscreen wiping devices.</p> <p>A windscreen washing and wiping device that complies as a minimum with the conditions set out in point 1.1.5 of Annex III to Regulation (EU) No 1008/2010 shall be deemed ‘adequate’.</p>
36	UNECE Regulation No 122 (Heating systems)	<p>(a) The passenger compartment shall be fitted with a heating system.</p> <p>(b) Combustion heaters and their installation shall comply with Annex 7 to UNECE Regulation No 122. In addition, LPG combustion heaters and LPG heating systems shall fulfil the requirements set out in Annex 8 to UNECE Regulation No 122.</p> <p>(c) Additional heating systems which are retrofitted shall comply with the requirements set out in that UNECE Regulation No 122.</p>
37	Regulation (EU) No 1009/2010 (Wheel guards)	<p>(a) The vehicle shall be designed as to protect other road users against thrown-up stones, mud, ice, snow and water and to reduce the dangers due to contact with the moving wheels.</p> <p>(b) The technical service may check that the technical requirements set out in Annex II to Regulation (EU) No 1009/2010 are complied with.</p> <p>(c) The provisions of section 3 of Annex I to that Regulation shall not apply.</p>

38	UNECE Regulation No 25 (Head restraints)	The requirements of UNECE Regulation No 25 shall not apply.
44	Regulation (EU) No 1230/2012 (Masses and dimensions)	<p>(a) The requirements of section 1 of Part A of Annex I to Regulation (EU) No 1230/2012 shall be fulfilled.</p> <p>(b) For the purposes of point (a), the masses to be considered are the following:</p> <ul style="list-style-type: none"> — the mass in running order defined in point 2.6 of Annex I to Regulation (EU) No 1230/2012 as measured by the technical service, and — the laden masses either stated by the vehicle manufacturer or shown on the manufacturer's plate including stickers or information available in the owner's manual. Those masses shall be deemed the technically permissible maximum laden masses. <p>(c) No exemption shall be permitted in respect of the maximum permissible dimensions.</p>
45	UNECE Regulation No 43(Safety glazing)	<p><i>Components</i></p> <p>(a) The glazing shall be made either of tempered or laminated safety glass.</p> <p>(b) Fitting of plastic glazing shall be permitted only on locations situated behind the 'B' pillar.</p> <p>(c) Glazing shall not be required to be approved under UNECE Regulation No 43.</p> <p><i>Installation</i></p> <p>(a) The installation requirements set out in Annex 21 to UNECE Regulation No 43 shall apply.</p> <p>(b) No tinted films that would reduce the regular light transmission under the required minimum shall be permitted on the windscreen and on the glazing located in front of the 'B' pillar.</p>

46	Directive 92/23/EEC (Tyres)	<p><i>Components</i></p> <p>Tyres shall bear an 'EC' type-approval mark including the symbol 's' (for sound).</p> <p><i>Installation</i></p> <p>(a) The dimensions, load-capacity index and speed category of the tyres shall fulfil the requirements of Annex IV to Directive 92/23/EEC.</p> <p>(b) The speed category symbol of the tyre shall be compatible with the maximum design speed of the vehicle.</p> <p>This requirement shall apply notwithstanding the presence of a speed limiter.</p> <p>(c) The maximum speed of the vehicle shall be stated by the vehicle manufacturer. However, the technical service may assess the maximum design speed of the vehicle by using the engine maximum power output, the maximum number of revolutions per minute and the data concerning the kinematic chain.</p>
----	------------------------------------	--

50	UNECE Regulation No 55 (Couplings)	<p><i>Separate technical units</i></p> <p>(a) OEM couplings intended for towing a trailer whose maximum mass does not exceed 1 500 kg shall not be required to be type-approved under UNECE Regulation No 55.</p> <p>A coupling is deemed OEM equipment where it is described in the owner's manual or an equivalent supporting document provided to the buyer by the vehicle manufacturer.</p> <p>Where such coupling is approved with the vehicle, an appropriate text shall be included in the approval certificate stating that the owner is responsible for ensuring compatibility with the coupling device fitted to the trailer.</p> <p>(b) Couplings other than those referred to in point (a), as well as couplings that are retrofitted, shall be type-approved in accordance with UNECE Regulation No 55.</p> <p><i>Installation on the vehicle</i></p> <p>The technical service shall check that the installation of the coupling devices comply with paragraph 6 of UNECE Regulation No 55.</p>
----	---------------------------------------	--

53	UNECE Regulation No 94 (Frontal impact) (c)	<p>(a) The applicant shall submit a statement from the manufacturer establishing that the particular vehicle, of which the VIN has to be specified, complies with at least one of the following:</p> <ul style="list-style-type: none"> — UNECE Regulation No 94, — FMVSS No 208 (Occupant crash protection), — Article 18 of JSRRV. <p>(b) A test in accordance with paragraph 5 of UNECE Regulation No 94 may be conducted on a production vehicle at the request of the applicant.</p> <p>The test shall be conducted by a technical service that has been designated for carrying out this test. A detailed report shall be issued by that technical service to the applicant</p>
54	UNECE Regulation No 95 (Side impact)	<p>(a) The applicant shall submit a statement from the manufacturer establishing that the particular vehicle, of which the VIN has to be specified complies with at least one of the following:</p> <ul style="list-style-type: none"> — UNECE Regulation No 95, — FMVSS No 214 (Side impact protection), — Article 18 of JSRRV. <p>(b) A test in accordance with section 5 of UNECE Regulation No 95 may be conducted on a production vehicle at the request of the applicant.</p> <p>The test shall be conducted by a technical service that has been designated for carrying out this test. A detailed report shall be issued by that technical service to the applicant.</p>

58	Regulation (EC) No 78/2009 (Pedestrian protection)	<p><i>Brake assist</i></p> <p>Vehicles shall be fitted with an electronic antilock braking system acting on all wheels.</p> <p><i>Pedestrian protection</i></p> <p>The requirements of Regulation (EC) No 78/2009 shall apply.</p> <p><i>Frontal protection systems</i></p> <p>Frontal protection systems installed on the vehicle shall be type-approved in accordance with Regulation (EC) No 78/2009 and their installation shall comply with the requirements set out in section 6 of Annex I to that Regulation.</p>
59	Directive 2005/64/EC (Recyclability)	The requirements of that Directive shall not apply.
61	Directive 2006/40/EC (Air-conditioning system)	The requirements of that Directive shall apply.
72	Regulation (EU) 2015/758 (eCall system)	The requirements of that Regulation shall not apply.

Part II: Vehicles belonging to category N₁

Item	Regulatory act reference	Alternative requirements
2a	<p>Regulation (EC) No 715/2007</p> <p>Emissions (Euro 5 and 6) light duty vehicles/access to information</p>	<p><i>Tailpipe emissions</i></p> <p>(a) A type I test shall be conducted in accordance with Annex III to Regulation (EC) No 692/2008 using the deterioration factors set out in point 1.4 of Annex VII to Regulation (EC) No 692/2008. The limits to be applied shall be those specified in Table I and Table II in Annex I to Regulation (EC) No 715/2007.</p> <p>(b) The vehicle shall not be required to exhibit 3 000 km as mentioned in paragraph 3.1.1 of Annex 4 to UNECE Regulation No 83.</p> <p>(c) The fuel to be used for the test shall be the reference fuel as prescribed in Annex IX to Regulation (EC) No 692/2008.</p> <p>(d) The dynamometer shall be set up in accordance with the technical requirements of paragraph 3.2 of Annex 4 to UNECE Regulation No 83.</p> <p>(e) The test referred to in point (a) shall not be conducted where it can be shown that the vehicle complies with the California Code Regulations referred to in point 2 of Annex I to Regulation (EC) No 692/2008.</p> <p><i>Evaporative emissions</i></p> <p>For petrol-fuelled engines, the presence of an evaporate emissions control system (e.g. a charcoal canister) shall be required.</p> <p><i>Crankcase emissions</i></p> <p>The presence of a device for recycling crankcase gases shall be required.</p> <p><i>OBD</i></p> <p>The vehicle shall be fitted with an OBD system.</p> <p>OBD-interface must be able to communicate with common diagnostic tools used for periodic technical inspections.</p>

	<p><i>Smoke opacity</i></p> <p>(a) Vehicles equipped with a diesel-fuelled engine shall be tested in accordance with the tests methods referred to in Appendix 2 to Annex IV to Regulation (EC) No 692/2008.</p> <p>(b) The corrected value of the absorption coefficient shall be affixed, conspicuously and in a readily accessible place.</p> <p><i>CO₂ emissions and fuel consumption</i></p> <p>(a) A test shall be conducted in accordance with Annex XII to Regulation (EC) No 692/2008.</p> <p>(b) The vehicle shall not be required to exhibit 3 000 km as requested in paragraph 3.1.1 of Annex 4 to UNECE Regulation No 83.</p> <p>(c) Where the vehicle complies with the California Code Regulations referred to in point 2 of Annex I to Commission Regulation (EC) No 692/2008 and therefore no test of tailpipe emissions is required to be performed, Member States shall calculate CO₂ emissions and fuel consumption with the formula laid down in the explanatory notes (b) and (c).</p> <p><i>Access to information</i></p> <p>The provisions regarding access to information shall not apply.</p> <p><i>Power measurement</i></p> <p>(a) The applicant shall submit a statement from the manufacturer stating the maximum engine power output in kW as well as the corresponding regime in revolutions per minute.</p> <p>(b) An engine power output curve providing the same information may alternatively be provided by the applicant.</p>
--	---

3	<p>UNECE Regulation No 34 (Fuel tanks — Rear protective devices)</p>	<p><i>Fuel tanks</i></p> <p>(a) Fuel tanks shall comply with paragraph 5 of UNECE Regulation No 34 with the exception of paragraphs 5.1, 5.2 and 5.12. In particular, they shall comply with paragraph 5.9 and 5.9.1 but no dripping test shall be conducted.</p> <p>(b) LPG or CNG tanks shall be type-approved in accordance with, respectively UNECE Regulations No 67, series of amendments 01, or Regulation No 110 ^(a).</p> <p><i>Specific provisions for fuel tanks made of a plastic material</i></p> <p>The applicant shall submit a statement from the manufacturer establishing that the fuel tank on the particular vehicle, of which the VIN has to be specified, complies either with at least one of the following:</p> <ul style="list-style-type: none"> — FMVSS No 301 (Fuel system integrity), — Annex 5 to UNECE Regulation No 34. <p><i>Rear protective device</i></p> <p>(a) The rear part of the vehicle shall be constructed in accordance with paragraphs 8 and 9 of UNECE Regulation No 34.</p>
4	<p>Regulation (EU) No 1003/2010 (Rear registration plate space)</p>	<p>Space, inclination, angles for visibility and position of the registration plate shall comply with Regulation (EU) No 1003/2010.</p>

5	UNECE Regulation No 79 (Steering effort)	<p><i>Mechanical systems</i></p> <p>(a) The steering mechanism shall be built as to self-centre. In order to check compliance with this provision, a test shall be conducted in accordance with paragraphs 6.1.2 and 6.2.1 of UNECE Regulation No 79.</p> <p>(b) The failure of the power steering equipment shall not lead to a complete loss of control of the vehicle.</p> <p><i>Complex electronic vehicle control system ('Drive-by wire' devices)</i></p> <p>Complex electronic control system shall be permitted only if they comply with Annex 6 to UNECE Regulation No 79.</p>
6	UNECE Regulation No 11 (Door latches and hinges)	Compliance with paragraph 6.1.5.4 of UNECE Regulation No 11
7	UNECE Regulation No 28 (Audible warning)	<p><i>Components</i></p> <p>The audible warning devices are not required to be type-approved in accordance with UNECE Regulation No 28. However, they shall emit a continuous sound as required in paragraph 6.1.1 of UNECE Regulation No 28.</p> <p><i>Installation on vehicle</i></p> <p>(a) A test shall be conducted in accordance with paragraph 6.2 of UNECE Regulation No 28.</p> <p>(b) The maximum sound pressure level shall be in accordance with paragraph 6.2.7.</p>

8	UNECE Regulation No 46 (Indirect vision devices)	<p><i>Components</i></p> <ul style="list-style-type: none"> (a) The vehicle shall be fitted with the rear-view mirrors prescribed in paragraph 15.2 of UNECE Regulation No 46. (b) They are not required to be type-approved in accordance with UNECE Regulation No 46. (c) The radii of curvature of the mirrors shall not cause significant image distortions. At the discretion of the technical service, the radii of curvature shall be checked in accordance with the method described in Appendix 1 to Annex 7 to UNECE Regulation No 46. The radii of curvature shall not be less than those required by paragraph 6.1.2.2.4 of UNECE Regulation No 46. <p><i>Installation on vehicle</i></p> <p>Measurement shall be conducted in order to ensure that the fields of vision comply with paragraph 15.2.4. of UNECE Regulation No 46.</p>
---	---	--

9	<p>UNECE Regulation No 13-H (Braking)</p>	<p><i>General provisions</i></p> <p>(a) The braking system shall be built in accordance with paragraph 5 of UNECE Regulation No 13-H.</p> <p>(b) Vehicles shall be fitted with an electronic antilock braking system acting on all wheels.</p> <p>(c) The performances of the braking system shall comply with Annex III to UNECE Regulation No 13-H.</p> <p>(d) For these purposes, road tests shall be conducted on a track the surface of which possesses high adhesion. The test on the parking brake shall be conducted on a 18 % gradient (up and down).</p> <p>Only those tests mentioned under the headings "Service brake" and "Parking brake" below shall be conducted. In each case, the vehicle shall be in fully laden conditions.</p> <p>(e) The road test referred to in point (c) shall not be conducted where the applicant can submit a statement from the manufacturer establishing that the vehicle complies either with UNECE Regulation No 13-H including supplement 5 or with FMVSS No 135.</p> <p><i>Service brake</i></p> <p>(a) A 'Type 0' test as prescribed in paragraphs 1.4.2 and 1.4.3 of Annex 3 to UNECE Regulation No 13-H shall be conducted.</p> <p>(b) In addition, a 'Type I' test as prescribed in paragraph 1.5 of Annex 3 to UNECE Regulation No 13-H shall be conducted.</p> <p><i>Parking brake</i></p> <p>A test shall be conducted in accordance with paragraph 2. 3 of Annex 3 to UNECE Regulation No 13-H.</p>
---	---	---

10	UNECE Regulation No 10 (Radio interference (electromagnetic compatibility))	<p><i>Components</i></p> <p>(a) Electrical/electronic sub-assemblies are not required to be type-approved in accordance with UNECE Regulation No 10.</p> <p>(b) However, electric/electronic devices retrofitted shall comply with UNECE Regulation No 10.</p> <p><i>Emitted electromagnetic radiations</i></p> <p>The applicant shall submit a statement from the manufacturer establishing that the vehicle complies with UNECE Regulation No 10 or with the following alternative standards:</p> <ul style="list-style-type: none"> — Broadband electromagnetic radiation: CISPR 12 or SAE J551-2, — Narrowband electromagnetic radiation: CISPR 12 (off-board) or 25 (in-board) or SAE J551-4 and SAE J1113-41. <p><i>Immunity tests</i></p> <p>Immunity test shall be waived.</p>
13	UNECE Regulation No 116 (Anti-theft and immobiliser)	<p>(a) In order to prevent unauthorised use, the vehicle shall be fitted with a locking device as defined in paragraph 5.1.2 of UNECE Regulation No 116.</p> <p>(b) If an immobiliser is fitted, it shall comply with the technical requirements of paragraph 8.1.1 of UNECE Regulation No 116.</p>

14	UNECE Regulation No 12 (Protective steering)	<p>(a) The applicant shall submit a statement from the manufacturer establishing that the particular vehicle, the VIN of which has to be specified, complies with at least one of the following:</p> <ul style="list-style-type: none"> — UNECE Regulation No 12, — FMVSS No 203 (Impact protection for the driver from the steering control system) including FMVSS No 204 (Steering control rearward displacement), — Article 11 of JSRRV. <p>(b) A test in accordance with Annex 3 to UNECE Regulation No 12 may be conducted on a production vehicle at the request of the applicant. The test shall be conducted by a technical service that has been designated for carrying out this test. A detailed report shall be issued by that technical service to the applicant.</p>
15	UNECE Regulation No 17 (Seats strength — head restraints)	<p><i>Seats, seat anchorages and adjustment systems</i></p> <p>Seats and their adjustable systems shall comply with paragraph 5.3 of UNECE Regulation No 17.</p> <p><i>Head restraints</i></p> <p>(a) Head restraints shall fulfil the requirements of section 5 of UNECE Regulation No 17 and Annex 4 to UNECE Regulation No 17.</p> <p>(b) Only the tests described in paragraphs 5.12, 6.5, 6.6 and 6.7 of UNECE Regulation No 17 shall be conducted.</p>

17	UNECE Regulation No 39 (Speedometer — reverse gear)	<p><i>Speedometer equipment</i></p> <p>(a) The dial shall comply with paragraphs 5.1 to 5.14 of UNECE Regulation No 39.</p> <p>(b) When the technical service has reasonable grounds to believe that the speedometer is not calibrated with a sufficient accuracy, it may require that the tests prescribed in paragraph 5.2 of UNECE Regulation No 39 be conducted.</p> <p><i>Reverse gear</i></p> <p>The gear mechanism shall include a reverse gear.</p>
18	Regulation (EU) No 19/2011 (Statutory plates)	<p><i>Vehicle identification number</i></p> <p>(a) The vehicle shall be fitted with a vehicle identification number comprising a minimum of 8 and a maximum of 17 characters. Vehicle identification number comprising 17 characters shall fulfil the requirements set out in Standards ISO 3779:1983 and 3780:1983.</p> <p>(b) The vehicle identification number shall be located in a clearly visible and accessible position in such a way as it cannot be obliterated or deteriorate.</p> <p>(c) Where no vehicle identification number is stamped in the chassis or in the body, a Member State may require that it is retrofitted in application of its national law. In such a case, the competent authority of that Member State shall supervise the operation.</p> <p><i>Statutory plate</i></p> <p>The vehicle shall be fitted with an identification plate affixed by the vehicle manufacturer.</p> <p>No additional plate shall be requested after the approval has been granted.</p>

19	UNECE Regulation No 14 (Seat belt anchorages)	<p>The applicant shall submit a statement from the manufacturer establishing that the particular vehicle, of which the VIN has to be specified, complies with at least one of the following:</p> <ul style="list-style-type: none"> — UNECE Regulation No 14, — FMVSS No 210 (Seat belt assembly anchorages), — Article 22-3 of JSRRV.
20	UNECE Regulation No 48 (Installation of lighting and light signalling devices)	<p>(a) The lighting installation shall meet the essential requirements of UNECE Regulation No 48 series of amendments 03 with the exception of those of Annexes 5 and 6 to UNECE Regulation No 48.</p> <p>(b) No exemption shall be permitted in respect of the number, the essential design characteristics, the electrical connections, and the colour of light emitted or retro-reflected of the lights and signalling devices referred to in items 21 to 26 and in items 28 to 30.</p> <p>(c) Lights and signalling devices that, for the purpose of fulfilling with the requirements of point (a) must be retrofitted shall bear an 'EU' type-approval mark.</p> <p>(d) Lamps fitted with gas-discharged light source are only permitted in conjunction with the installation of headlamp cleaning device and an automatic headlamp-levelling device where appropriate.</p> <p>(e) Headlamp dipped-beams shall be adapted to the direction of traffic legally in force in the country where the vehicle is granted approval.</p>

21	UNECE Regulation No 3 (Retro reflectors)	Where necessary, two additional retro reflectors bearing an 'EC' approval mark shall be added at the rear, the position of which shall comply with UNECE Regulation No 48.
22	UNECE Regulations No 7, No 87 and No 91 (End-outline, front position (side), rear-position (side), stop, side marker, daytime running lamps)	The requirements set out in UNECE Regulations No 7, No 87 and No 91 shall not apply. However, the correct functioning of the lights shall be checked by the technical service.
23	UNECE Regulation No 6 (Direction indicators)	The requirements set out in UNECE Regulation No 6 shall not apply. However, the correct functioning of the lights shall be checked by the technical service.
24	UNECE Regulation No 4 (Rear registration plate lamps)	The requirements set out in UNECE Regulation No 4 shall not apply. However, the correct functioning of the lights shall be checked by the technical service.
25	UNECE Regulations No 98, No 112 and No 123 (Headlamps (including bulbs))	(a) The illumination produced by the passing beam of the headlamps fitted to the vehicle shall be checked under the provisions of paragraph 6 of UNECE Regulation No 112 concerning headlamps emitting an asymmetrical passing beam. The tolerances included in Annex 5 to that Regulation may be referred to for that purpose. (b) The same requirement shall apply to the passing beam of headlamps covered by UNECE Regulation No 98 or No 123.
26	UNECE Regulation No 19 (Front fog lamps)	The provisions of UNECE Regulation No 19 shall be waived. However, the correct functioning of the lights if fitted shall be checked by the technical service.

27	Regulation (EU) No 1005/2010 (Towing hooks)	The requirements of Regulation (EU) No 1005/2010 shall be waived.
28	UNECE Regulation No 38 (Rear fog lamps)	The provisions of UNECE Regulation No 38 shall be waived. However, the correct functioning of the lights shall be checked by the technical service.
29	UNECE Regulation No 23 (Reversing lamps)	The provisions of UNECE Regulation No 23 shall be waived. However, the correct functioning of the lights if fitted shall be checked by the technical service.
30	UNECE Regulation No 77 (Parking lamps)	The provisions of UNECE Regulation No 77 shall be waived. However, the correct functioning of the lights if fitted shall be checked by the technical service.
31	UNECE Regulation No 16 (Seat belts and restraint systems)	<p><i>Components</i></p> <p>(a) Seat belts shall not be required to be type-approved in accordance with UNECE Regulation No 16.</p> <p>(b) However, each seat belt shall bear an identification label.</p> <p>(c) The indications on the label shall be consistent with the decision concerning seat belt anchorages (Re: entry 19).</p> <p><i>Installation requirements</i></p> <p>(a) The vehicle shall be fitted with seat belts in accordance with the requirements set out in Annex XVI to UNECE Regulation No 16.</p> <p>(b) Where a number of seat belts have to be retrofitted in accordance with point (a), they shall be of an approved type in accordance with UNECE Regulation No 16.</p>

33	UNECE Regulation No 121 (Identification of controls, tell-tales and indicators)	<p>(a) The symbols including the colour of their corresponding tell-tales the presence of which is mandatory by virtue of UNECE Regulation No 121 shall comply with that UNECE Regulation.</p> <p>(b) Where this is not the case, the technical service shall verify that the symbols, tell-tales and indicators fitted to the vehicle provide the driver with comprehensible information about the operation of the controls in question.</p>
34	Regulation (EU) No 672/2010 (Defrost/Demist)	The vehicle shall be equipped with adequate windscreen defrosting and windscreen demisting devices.
35	Regulation (EU) No 1008/2010 (Wash/Wipe)	The vehicle shall be equipped with adequate windscreen washing and windscreen wiping devices.
36	UNECE Regulation No 122 (Heating systems)	<p>(a) The passenger compartment shall be fitted with a heating system.</p> <p>(b) Combustion heaters and their installation shall comply with Annex 7 to UNECE Regulation No 122. In addition, LPG combustion heaters and LPG heating systems shall fulfil the requirements set out in Annex 8 to UNECE Regulation No 122.</p> <p>(c) Additional heating systems that are retrofitted shall comply with the requirements set out in UNECE Regulation No 122.</p>

41a	<p>Regulation (EC) No 595/2009</p> <p>Emissions (Euro VI) heavy-duty vehicles – OBD</p>	<p><i>Tailpipe emissions</i></p> <p>(a) A test shall be conducted in accordance with Annex III to Regulation (EU) No 582/2011 using the deterioration factors set out in point 3.6.1. of Annex VI to Regulation (EU) No 582/2011.</p> <p>(b) The limits to be applied shall be those set out in the table of Annex I to Regulation (EC) No 595/2009.</p> <p>(c) The fuel to be used for the test shall be the reference fuel as prescribed in Annex IX to Regulation (EU) No 582/2011.</p> <p><i>CO₂ emissions</i></p> <p>The CO₂ emissions and fuel consumption shall be determined in accordance with Annex VIII to Regulation (EU) No 582/2011.</p> <p><i>OBD</i></p> <p>(a) The vehicle shall be fitted with an OBD system.</p> <p>(b) The OBD-interface must be able to communicate with an external OBD scan-tool as described in Annex X to Regulation (EU) No 582/2011.</p> <p><i>Requirements to ensure the correct operation of NO_x control measures</i></p> <p>The vehicle shall be fitted with a system ensuring the correct operation of NO_x control measures in accordance with Annex XIII to Regulation (EU) No 582/2011.</p> <p><i>Power measurement</i></p> <p>(a) The applicant shall submit a statement from the manufacturer stating the maximum engine power output in Kw as well as the corresponding regime</p> <p>(b) An engine power output curve providing the same information may alternatively be provided by the applicant.</p>
-----	---	---

45	UNECE Regulation No 43	<p><i>Components</i></p> <ul style="list-style-type: none"> (a) The glazing shall be made either of tempered or laminated safety glass. (b) Fitting of plastic glazing shall be permitted only on locations situated behind the 'B' pillar. (c) Glazing shall not be required to be approved under UNECE Regulation No 43. <p><i>Installation</i></p> <ul style="list-style-type: none"> (a) The installation requirements set out in Annex 21 to UNECE Regulation No 43 shall apply. (b) No tinted films that reduce the regular light transmission under the required minimum shall be permitted on the windscreen and on the glazing located in front of the 'B' pillar.
46	Commission Regulation (EU) 458/2011 (Installation of tyres)	<p><i>Installation</i></p> <ul style="list-style-type: none"> (a) The dimensions, load-capacity index and speed category of the tyres shall fulfil the requirements of Commission Regulation (EU) 458/2011. (b) The speed category symbol of the tyre shall be compatible with the maximum design speed of the vehicle. (c) This requirement shall apply notwithstanding the presence of a speed limiter. (d) The maximum speed of the vehicle shall be stated by the vehicle manufacturer. However, the technical service may assess the maximum design speed of the vehicle by using the engine maximum power output, the maximum number of revolutions per minute and the data concerning the kinematic chain.

46B	UNECE Regulation No 30 (C1 tyres)	<i>Components</i> Tyres shall bear an 'E' type-approval mark.
46D	UNECE Regulation No 117 (tyre rolling sound emissions, adhesion on wet surface and rolling resistance)	<i>Components</i> Tyres shall bear an 'E' type-approval mark.
46D	Regulation (EC) No 661/2009 UNECE Regulation No 64 (temporary use spare unit, run-flat tyres, tyre rolling sound emissions, adhesion on wet surface and rolling resistance)	<i>Components</i> Tyres shall bear an 'E' type-approval mark. The fitting of TPMS shall not be required

48	<p>Regulation (EU) No 1230/2012</p> <p>(Masses and dimensions)</p>	<p>(a) The requirements of Annex I, Part A to Regulation (EU) No 1230/2012 shall be fulfilled.</p> <p>However, the requirements set out in point 5 of Part A of Annex I do not need to be fulfilled.</p> <p>(b) For the purposes of point (a) the masses to be considered are the following:</p> <ul style="list-style-type: none"> — the mass in running order as defined in Article 2(4) of Regulation (EU) No 1230/2012 as measured by the technical service, and — the maximum laden masses either stated by the vehicle manufacturer or shown on the manufacturer's plate, including stickers or information available in the owner's manual. Those masses shall be regarded as the technically permissible maximum laden masses. <p>(c) Technical changes made by the applicant in order to decrease the maximum technically permissible laden mass of the vehicle to 3,5 tonnes or less, so that the vehicle may be granted individual vehicle approval shall not be permitted.</p> <p>(d) No exemption shall be permitted in respect of the maximum permissible dimensions.</p>
49	<p>UNECE Regulation No 61 (External projections of cabs)</p>	<p>(a) The general requirements set out in section 5 of UNECE Regulation No 17 shall be fulfilled.</p> <p>(b) At the discretion of the technical service, the requirements set out in paragraphs 6.1, 6.5, 6.6, 6.7, 6.8 and 6.11 of UNECE Regulation No 17 shall be fulfilled.</p>

50	UNECE Regulation No 55 (Couplings)	<p><i>Separate technical units</i></p> <p>(a) OEM couplings intended for towing a trailer of which the maximum mass does not exceed 1 500 kg shall not be required to be type-approved under UNECE Regulation No 55.</p> <p>(b) A coupling is deemed OEM equipment where it is described in the owner's manual or in an equivalent supporting document provided to the buyer by the vehicle manufacturer.</p> <p>(c) Where such coupling is approved with the vehicle, an appropriate text shall be included in the approval certificate stating that the owner is responsible for ensuring compatibility with the coupling device fitted to the trailer.</p> <p>(d) Couplings other than those referred to in point (a), as well as couplings that are retrofitted, shall be type-approved in accordance with UNECE Regulation No 55.</p> <p><i>Installation on the vehicle</i></p> <p>The technical service shall check that the installation of the coupling devices comply with paragraph 6 to UNECE Regulation No 55.</p>
----	---------------------------------------	--

54	UNECE Regulation No 95 (Side impact)	<p>(a) The applicant shall submit a statement from the manufacturer establishing that the particular vehicle, of which the VIN has to be specified, complies with at least one of the following:</p> <ul style="list-style-type: none"> — UNECE Regulation No 95, — FMVSS No 214 (Side impact protection), — Article 18 of JSRRV. <p>(b) A test in accordance with section 5 of UNECE Regulation No 95 may be conducted on a production vehicle at the request of the applicant.</p> <p>(c) The test shall be conducted by a technical service that been designated for carrying out this test. A detailed report shall be issued by that technical service to the applicant.</p>
56	UNECE Regulation No 105 Vehicles intended for the transport of dangerous goods	Vehicles intended for the transport of dangerous goods shall comply with UNECE Regulation No 105.

58	Regulation (EC) No 78/2009 (Pedestrian protection)	<p><i>Brake assist</i></p> <p>Vehicles shall be fitted with an electronic antilock braking system acting on all wheels.</p> <p><i>Pedestrian protection</i></p> <p>Until 24 February 2018, the requirements of Regulation (EC) No 78/2009 shall not apply to vehicles of which the maximum mass does not exceed 2 500 kg and until 24 August 2019 to vehicles of which the maximum mass exceeds 2 500 kg.</p> <p><i>Frontal protection systems</i></p> <p>However, frontal protection systems installed on the vehicle shall be type-approved in accordance with Regulation (EC) No 78/2009 and their installation shall comply with the requirements set out in section 6 of Annex I to that Regulation.</p>
59	Directive 2005/64/EC (Recyclability)	The requirements of that Directive shall not apply.
61	Directive 2006/40/EC (Air-conditioning system)	The requirements of that Directive shall apply.
72	Regulation (EU) 2015/758 (eCall system)	The requirements of that Regulation shall not apply.

Explanatory notes to Appendix 2

1. Abbreviations used in this Appendix:

‘OEM’: original equipment provided by the manufacturer

‘FMVSS’: Federal Motor Vehicle Safety Standard of the U.S Department of Transportation

‘JSRRV’: Japan Safety Regulations for Road Vehicles

‘SAE’: Society of Automotive Engineers

‘CISPR’: Comité international spécial des perturbations radioélectriques.

2. Remarks:

(a) the complete LPG or CNG installation shall be checked against the provisions of UNECE Regulations No 67, No 110 or No 115, as appropriate;

(b) the formula to be used for the assessment of CO₂ emissions shall be as follows:

Petrol engine and manual gearbox:

$$\text{CO}_2 = 0,047 m + 0,561 p + 56,621$$

Petrol engine and automatic gearbox:

$$\text{CO}_2 = 0,102 m + 0,328 p + 9,481$$

Petrol engine and hybrid electric:

$$\text{CO}_2 = 0,116 m - 57,147$$

Diesel engine and manual gearbox:

$$\text{CO}_2 = 0,108 m - 11,371$$

Diesel engine and automatic gearbox:

$$\text{CO}_2 = 0,116 m - 6,432$$

Where: CO₂ is the combined mass of CO₂ emissions in g/km, ‘m’ is the mass of the vehicle in running order in kg and ‘p’ the maximum engine power output in kW.

Combined mass of CO₂ shall be calculated with one decimal place, then rounded to the nearest whole number as follows:

(i) if the figure following the decimal point is below 5, the total is rounded down;

(ii) if the figure following the decimal point is equal to 5 or above 5, the total is rounded up;

(c) the formulæ to be used for the assessment of fuel consumption shall be as follows:

$$\text{CFC} = \text{CO}_2 \times k^{-1}$$

Where: CFC is the combined fuel consumption in l/100 km, CO₂ is the combined mass of CO₂ emissions in g/km after it has been rounded in accordance with the rule referred to in Remark (2 b), 'k' a coefficient equal to:

23,81 in the case of a petrol engine;

26,49 in the case of a diesel engine.

Combined fuel consumption shall be calculated with two decimal places, then rounded as follows:

(i) if the figure following the first decimal is below 5, the total is rounded down;

(ii) if the figure following the first decimal is equal to 5 or above 5, the total is rounded up.

PART II

List of UNECE regulations recognised as an alternative to the Directives or Regulations referred to in Part I

Where reference is made to a separate Directive or Regulation in the table of Part I, an approval granted under the following UNECE regulations which the Community has accepted as a Contracting Party to the United Nations Economic Commission for Europe 'Revised 1958 Agreement' by virtue of Council Decision 97/836/EC³⁵, or subsequent Council Decisions as referred to in Article 3(3) of that Decision, shall be considered as equivalent to an EU type-approval granted under the relevant separate Directive or Regulation.

Any further amendment to the UNECE regulations listed in the following table ³⁶ shall also be deemed to be equivalent to an EU type-approval, subject to the Decision referred to in Article 4(2) of Decision 97/836/EC.

³⁵ Council Decision 97/836/EC of 27 November 1997 with a view to accession by the European Community to the Agreement of the United Nations Economic Commission for Europe concerning the adoption of uniform technical prescriptions for wheeled vehicles, equipment and parts which can be fitted to and/or be used on wheeled vehicles and the conditions for reciprocal recognition of approvals granted on the basis of these prescriptions ('Revised 1958 Agreement') (OJ L 346, 17.12.1997, p. 78).

³⁶ For subsequent amendments, see UNECE TRANS/WP.29/343.

	Subject	Basic UNECE Regulation number	Series of amendments
1A (*)	Permissible sound level (not covering AVAS and replacement silencers)	51	03
	AVAS	138	00
	Replacement silencing systems	59	02
9B.	Braking of passenger cars(ESC part)	140	00
58.	Pedestrian protection (not covering brake assist)	127 (pedestrian protection)	00
	Pedestrian protection (brake assist part)	13-H (brake assist) or 139 (brake assist)	00 (Supplement 9 and above) 00
65	Advanced emergency braking system	131	01
66	Lane departure warning system	130	00

Where the separate Directive or Regulation contains installation requirements, these apply also to components and separate technical units approved in accordance with UNECE regulations.

(*) The numbering of the entries in this table refers to the numbering used in the table of Part I.

PART III

List of regulatory acts setting out the requirements for the purpose of EU type-approval of special purpose vehicles

Appendix 1

Motor-caravans, ambulances and hearses

Item	Subject	Regulatory act reference	M ₁ ≤ 2500 kg(*)	M ₁ > 2500 kg(*)	M ₂	M ₃
1	Sound level	Directive 70/157/EEC	H	G+H	G+H	G+H
1A	Sound level	Regulation (EU) No 540/2014	H	G+H	G+H	G+H
2	Emissions (Euro 5 and 6) light duty vehicles / access to information	Directive 70/220/EEC	Q ⁽¹⁾	G + Q ⁽¹⁾	G + Q ⁽¹⁾	
3A	Prevention of fire risks (liquid fuel tanks)	Regulation (EC) No 661/2009 UNECE Regulation No 34	F ⁽²⁾	F ⁽²⁾	F ⁽²⁾	F ⁽²⁾
3B	Rear underrun protective devices (RUPDs) and their installation; rear underrun protection (RUP)	Regulation (EC) No 661/2009 UNECE Regulation No 58	X	X	X	X

4A	Space for mounting and fixing rear registration plates	Regulation (EC) No 661/2009 Regulation (EU) No 1003/2010	X	X	X	X
5A	Steering equipment	Regulation (EC) No 661/2009 UNECE Regulation No 79	X	G	G	G
6A	Vehicle access and manoeuvrability	Regulation (EC) No 661/2009 Regulation (EU) No 130/2012	X	X		
6B	Door latches and door retention components	Regulation (EC) No 661/2009 UNECE Regulation No 11	B	G+B		
7A	Audible warning devices and signals	Regulation (EC) No 661/2009 UNECE Regulation No 28	X	X	X	X

Item	Subject	Regulatory act reference	M ₁ ≤ 2500 kg(*)	M ₁ > 2500 kg(*)	M2	M3
8A	Devices for indirect vision and their installation	Regulation (EC) No 661/2009 UNECE Regulation No 46	X	G	G	G
9A	Braking of vehicles and trailers	Regulation (EC) No 661/2009 UNECE Regulation No 13-H	X ⁽⁴⁾	G+A ₁		
9B	Braking of vehicles and trailers	Regulation (EC) No 661/2009 UNECE Regulation No 13			G ⁽³⁾	G ⁽³⁾
10A	Electromagnetic compatibility	Regulation (EC) No 661/2009 UNECE Regulation No 10	X	X	X	X
12A	Interior fittings	Regulation (EC) No 661/2009 UNECE Regulation No 21	C	G+C		

13A	Protection of motor vehicles against unauthorised use	Regulation (EC) No 661/2009 UNECE Regulation No 18			G ^(4A)	G ^(4A)
13B	Protection of motor vehicles against unauthorised use	Regulation (EC) No 661/2009 UNECE Regulation No 116	X	G		
14A	Protection of the driver against the steering mechanism in the event of impact	Regulation (EC) No 661/2009 UNECE Regulation No 12	X	G		
15A	Seats, their anchorages and any head restraints	Regulation (EC) No 661/2009 UNECE Regulation No 17	D	G+D	G+D ^(4B)	G+D ^(4B)
15B	Seats of large passenger vehicles	Regulation (EC) No 661/2009 UNECE Regulation No 80			X	X
16A	External projections	Regulation (EC) No 661/2009 UNECE Regulation No 26	X for the cab; A+Z for the remaining part	G for the cab; A+Z for the remaining part		

Item	Subject	Regulatory act reference	M ₁ ≤ 2500 kg(*)	M ₁ > 2500 kg(*)	M2	M3
17A	Vehicle access and manoeuvrability	Regulation (EC) No 661/2009 Regulation (EU) No 130/2012	X	X	X	X
17B	Speedometer equipment including its installation	Regulation (EC) No 661/2009 UNECE Regulation No 39	X	X	X	X
18A	Manufacturer's statutory plate and vehicle identification number	Regulation (EC) No 661/2009 Regulation (EU) No 19/2011	X	X	X	X
19A	Safety-belt anchorages, Isofix anchorages systems and Isofix top tether anchorages	Regulation (EC) No 661/2009 UNECE Regulation No 14	D	G+L	G+L	G+L
20A	Installation of lighting and light-signalling devices on vehicles	Regulation (EC) No 661/2009 UNECE Regulation No 48	A+N	A+G+N for the cab; A+N for the remaining part	A+G+N for the cab; A+N for the remaining part	A+G+N for the cab; A+N for the remaining part

21A	Retro-reflecting devices for power-driven vehicles and their trailers	Regulation (EC) No 661/2009 UNECE Regulation No 3	X	X	X	X
22A	Front and rear position lamps, stop-lamps and end-outline marker lamps for motor vehicles and their trailers	Regulation (EC) No 661/2009 UNECE Regulation No 7	X	X	X	X
22B	Daytime running lamps for power-driven vehicles	Regulation (EC) No 661/2009 UNECE Regulation No 87	X	X	X	X
22C	Side-marker lamps for motor vehicles and their trailers	Regulation (EC) No 661/2009 UNECE Regulation No 91	X	X	X	X
23A	Direction indicators for power-driven vehicles and their trailers	Regulation (EC) No 661/2009 UNECE Regulation No 6	X	X	X	X

Item	Subject	Regulatory act reference	M ₁ ≤ 2500 kg(*)	M ₁ > 2500 kg(*)	M2	M3
24A	Illumination of rear-registration plates of power-driven vehicles and their trailers	Regulation (EC) No 661/2009 UNECE Regulation No 4	X	X	X	X
25A	Power-driven vehicle's sealed-beam headlamps (SB) emitting an European asymmetrical passing beam or a driving beam or both	Regulation (EC) No 661/2009 UNECE Regulation No 31	X	X	X	X
25B	Filament lamps for use in approved lamp units of power-driven vehicles and their trailers	Regulation (EC) No 661/2009 UNECE Regulation No 37	X	X	X	X
25C	Motor vehicle headlamps equipped with gas-discharge light sources	Regulation (EC) No 661/2009 UNECE Regulation No 98	X	X	X	X

25D	Gas-discharge light sources for use in approved gas-discharge lamp units of power-driven vehicles	Regulation (EC) No 661/2009 UNECE Regulation No 99	X	X	X	X
25E	Motor vehicle headlamps emitting an asymmetrical passing beam or a driving beam or both and equipped with filament lamps and/or LED modules	Regulation (EC) No 661/2009 UNECE Regulation No 112	X	X	X	X
25F	Adaptive front-lighting systems (AFS) for motor vehicles	Regulation (EC) No 661/2009 UNECE Regulation No 123	X	X	X	X
26A	Power-driven vehicle front fog lamps	Regulation (EC) No 661/2009 UNECE Regulation No 19	X	X	X	X
27A	Towing device	Regulation (EC) No 661/2009 Regulation (EU) No 1005/2010	E	E	E	E
28A	Rear fog lamps for power-driven vehicles and their trailers	Regulation (EC) No 661/2009 UNECE Regulation No 38	X	X	X	X

Item	Subject	Regulatory act reference	M ₁ ≤ 2500 kg(*)	M ₁ > 2500 kg(*)	M2	M3
29A	Reversing lights for power-driven vehicles and their trailers	Regulation (EC) No 661/2009 UNECE Regulation No 23	X	X	X	X
30A	Parking lamps for power-driven vehicles	Regulation (EC) No 661/2009 UNECE Regulation No 77	X	X	X	X
31A	Safety-belts, restraint systems, child restraint systems and Isofix child restraint systems	Regulation (EC) No 661/2009 UNECE Regulation No 16	D	G+M	G+M	G+M
32A	Forward field of vision	Regulation (EC) No 661/2009 UNECE Regulation No 125	X	G		
33A	Location and identification of hand controls, tell-tales and indicators	Regulation (EC) No 661/2009 UNECE Regulation No 121	X	X	X	X
34A	Windscreen defrosting and demisting systems	Regulation (EC) No 661/2009 Regulation (EU) No 672/2010	X	G (°)	(°)	(°)

35A	Windscreen wiper and washer systems	Regulation (EC) No 661/2009 Regulation (EU) No 1008/2010	X	G ⁽⁶⁾	⁽⁶⁾	⁽⁶⁾
36A	Heating systems	Regulation (EC) No 661/2009 UNECE Regulation No 122	X	X	X	X
37A	Wheel guards	Regulation (EC) No 661/2009 Regulation (EU) No 1009/2010	X	G		
38A	Head restraints (headrests), whether or not incorporated in vehicle seats	Regulation (EC) No 661/2009 UNECE Regulation No 25	D	G + D		
44A	Masses and dimensions	Regulation (EC) No 661/2009 Regulation (EU) No 1230/2012	X	X		

Item	Subject	Regulatory act reference	M1 ≤ 2500 kg(*)	M1 > 2500 kg(*)	M2	M3
45A	Safety glazing materials and their installation on vehicles	Regulation (EC) No 661/2009 UNECE Regulation No 43	J	G+J	G+J	G+J
46	Tyres	Directive 92/23/EEC	X	G	G	G
46A	Installation of tyres	Regulation (EC) No 661/2009 Regulation (EU) No 458/2011	X	G	G	G
46B	Pneumatic tyres for motor vehicles and their trailers (Class C1)	Regulation (EC) No 661/2009 UNECE Regulation No 30	X	G		
46C	Pneumatic tyres for commercial vehicles and their trailers (Classes C2 and C3)	Regulation (EC) No 661/2009 UNECE Regulation No 54	—	G	G	G

46D	Tyre rolling sound emissions, adhesion on wet surfaces and rolling resistance (Classes C1, C2 and C3)	Regulation (EC) No 661/2009 UNECE Regulation No 117	X	G	G	G
46E	Temporary-use spare unit, run-flat tyres/system and tyre pressure monitoring system	Regulation (EC) No 661/2009 UNECE Regulation No 64	X	G		
47A	Speed limitation of vehicles	Regulation (EC) No 661/2009 UNECE Regulation No 89			X	X

Item	Subject	Regulatory act reference	M1 ≤ 2500 kg(*)	M1 > 2500 kg(*)	M2	M3
48A	Masses and dimensions	Regulation (EC) No 661/2009 Regulation (EU) No 1230/2012			X	X
50A	Mechanical coupling components of combinations of vehicles	Regulation (EC) No 661/2009 UNECE Regulation No 55	X ⁽¹⁰⁾	G ⁽¹⁰⁾	G ⁽¹⁰⁾	G ⁽¹⁰⁾
51A	Burning behaviour of materials used in the interior construction of certain categories of motor vehicles	Regulation (EC) No 661/2009 UNECE Regulation No 118				G for the cab; X for the remaining part
52A	M ₂ and M ₃ vehicles	Regulation (EC) No 661/2009 UNECE Regulation No 107			A	A

52B	Strength of the superstructure of large passenger vehicles	Regulation (EC) No 661/2009 UNECE Regulation No 66			A	A
53A	Protection of occupants in the event of a frontal collision	Regulation (EC) No 661/2009 UNECE Regulation No 94	N/A	N/A		
54A	Protection of occupants in the event of lateral collision	Regulation (EC) No 661/2009 UNECE Regulation No 95	N/A	N/A		
58	Pedestrian protection	Regulation (EC) No 78/2009	X	N/A However, any frontal protection systems supplied with the vehicle shall comply and shall be marked		
59	Recyclability	Directive 2005/64/EC	N/A	N/A		
61	Air-conditioning system	Directive 2006/40/EC	X	G ⁽¹⁴⁾		
62	Hydrogen system	Regulation (EC) No 79/2009	Q	G + Q	G + Q	G + Q

Item	Subject	Regulatory act reference	M1 ≤ 2500 kg(*)	M1 > 2500 kg(*)	M2	M3
63	General safety	Regulation (EC) No 661/2009	X ⁽¹⁵⁾	X ⁽¹⁵⁾	X ⁽¹⁵⁾	X ⁽¹⁵⁾
64	Gear shift indicators	Regulation (EC) No 661/2009 Regulation (EU) No 65/2012	X	G		
65	Advanced emergency braking system	Regulation (EC) No 661/2009 Regulation (EU) No 347/2012			N/A ⁽¹⁶⁾	N/A ⁽¹⁶⁾
66	Lane departure warning system	Regulation (EC) No 661/2009 Regulation (EU) No 351/2012			N/A ⁽¹⁷⁾	N/A ⁽¹⁷⁾
67	Specific components for liquefied petroleum gases (LPG) and their installation on motor vehicles	Regulation (EC) No 661/2009 UNECE Regulation No 67	X	X	X	X

68	Vehicle alarm systems (VAS)	Regulation (EC) No 661/2009 UNECE Regulation No 97	X	G		
69	Electrical safety	Regulation (EC) No 661/2009 UNECE Regulation No 100	X	X	X	X
70	Specific components for CNG and their installation on motor vehicles	Regulation (EC) No 661/2009 UNECE Regulation No 110	X	X	X	X
72	eCall system	Regulation (EU) 2015/758	G	G	N/A	N/A

(*) Technically permissible maximum laden mass.

Additional requirements for ambulances

The patient compartment of ambulances shall comply with the requirements of EN 1789:2007 +A1:2010 +A2:2014 on Medical vehicles and their equipment – Road ambulances with the exception of section 6.5, list of equipment. Proof of compliance shall be provided with a test report of a technical service. If a wheelchair space is foreseen, the requirements of Appendix 3 relating to the wheelchair tie down and occupant restraint systems shall apply.

Appendix 2

Armoured vehicles

Item	Subject	Regulatory act reference	M ₁	M ₂	M ₃	N ₁	N ₂	N ₃	O ₁	O ₂	O ₃	O ₄
1A	Sound level	Regulation (EU) No 540/2014	X	X	X	X	X	X				
2	Emissions (Euro 5 and 6) light duty vehicles/access to information	Regulation (EC) No 715/2007	A ⁽¹⁾	A ⁽¹⁾		A ⁽¹⁾	A ⁽¹⁾					
3A	Prevention of fire risks (liquid fuel tanks)	Regulation (EC) No 661/2009 UNECE Regulation No 34	X ⁽²⁾	X ⁽²⁾	X ⁽²⁾	X ⁽²⁾	X ⁽²⁾	X ⁽²⁾	X	X	X	X
3B	Rear underrun protective devices (RUPDs) and their installation; rear underrun protection (RUP)	Regulation (EC) No 661/2009 UNECE Regulation No 58	X	X	X	X	A	A	X	X	X	X

4A	Space for mounting and fixing rear registration plates	Regulation (EC) No 661/2009 Regulation (EU) No 1003/2010	X	X	X	X	X	X	X	X	X	X	X
5A	Steering equipment	Regulation (EC) No 661/2009 UNECE Regulation No 79	X	X	X	X	X	X	X	X	X	X	X
6A	Vehicle access and manoeuvrability	Regulation (EC) No 661/2009 Regulation (EU) No 130/2012	X	X	X	X	X	X					
6B	Door latches and door retention components	Regulation (EC) No 661/2009 UNECE Regulation No 11	X			X							
7A	Audible warning devices and signals	Regulation (EC) No 661/2009 UNECE Regulation No 28	A+K	A+K	A+K	A+K	A+K	A+K					

8A	Devices for indirect vision and their installation	Regulation (EC) No 661/2009 UNECE Regulation No 46	A	A	A	A	A	A					
9A	Braking of vehicles and trailers	Regulation (EC) No 661/2009 UNECE Regulation No 13		X ⁽³⁾	X ⁽³⁾	X ⁽³⁾	X ⁽³⁾	X ⁽³⁾	X ⁽³⁾	X ⁽³⁾	X ⁽³⁾	X ⁽³⁾	X ⁽³⁾
9B	Braking of passenger cars	Regulation (EC) No 661/2009 UNECE Regulation No 13-H	X ⁽⁴⁾			X ⁽⁴⁾							
10A	Electromagnetic compatibility	Regulation (EC) No 661/2009 UNECE Regulation No 10	X	X	X	X	X	X	X	X	X	X	X
12A	Interior fittings	Regulation (EC) No 661/2009 UNECE Regulation No 21	A										

13A	Protection of motor vehicles against unauthorised use	Regulation (EC) No 661/2009 UNECE Regulation No 18		X ^(4A)	X ^(4A)		X ^(4A)	X ^(4A)					
13B	Protection of motor vehicles against unauthorised use	Regulation (EC) No 661/2009 UNECE Regulation No 116	X			X							
14A	Protection of the driver against the steering mechanism in the event of impact	Regulation (EC) No 661/2009 UNECE Regulation No 12	N/A			N/A							
15A	Seats, their anchorages and any head restraints	Regulation (EC) No 661/2009 UNECE Regulation No 17	X	D ^(4B)	D ^(4B)	D	D	D					
15B	Seats of large passenger vehicles	Regulation (EC) No 661/2009 UNECE Regulation No 80		D	D								

16A	External projections	Regulation (EC) No 661/2009 UNECE Regulation No 26	A										
17A	Vehicle access and manoeuvrability	Regulation (EC) No 661/2009 Regulation (EU) No 130/2012	X	X	X	X	X	X					
17B	Speedometer equipment including its installation	Regulation (EC) No 661/2009 UNECE Regulation No 39	X	X	X	X	X	X					
18A	Manufacturer's statutory plate and vehicle identification number	Regulation (EC) No 661/2009 Regulation (EU) No 19/2011	X	X	X	X	X	X	X	X	X	X	X
19A	Safety-belt anchorages, Isofix anchorages systems and Isofix top tether anchorages	Regulation (EC) No 661/2009 UNECE Regulation No 14	A	A	A	A	A	A					

20A	Installation of lighting and light-signalling devices on vehicles	Regulation (EC) No 661/2009 UNECE Regulation No 48	A+N	A+N	A+N	A+N	A+N	A+N	A+N	A+N	A+N	A+N	A+N
21A	Retro-reflecting devices for power-driven vehicles and their trailers	Regulation (EC) No 661/2009 UNECE Regulation No 3	X	X	X	X	X	X	X	X	X	X	X
22A	Front and rear position lamps, stop-lamps and end-outline marker lamps for motor vehicles and their trailers	Regulation (EC) No 661/2009 UNECE Regulation No 7	X	X	X	X	X	X	X	X	X	X	X
22B	Daytime running lamps for power-driven vehicles	Regulation (EC) No 661/2009 UNECE Regulation No 87	X	X	X	X	X	X					

22C	Side-marker lamps for motor vehicles and their trailers	Regulation (EC) No 661/2009 UNECE Regulation No 91	X	X	X	X	X	X	X	X	X	X	X
23A	Direction indicators for power-driven vehicles and their trailers	Regulation (EC) No 661/2009 UNECE Regulation No 6	X	X	X	X	X	X	X	X	X	X	X
24A	Illumination of rear-registration plates of power-driven vehicles and their trailers	Regulation (EC) No 661/2009 UNECE Regulation No 4	X	X	X	X	X	X	X	X	X	X	X
25A	Power-driven vehicle's sealed-beam headlamps (SB) emitting an European asymmetrical passing beam or a driving beam or both	Regulation (EC) No 661/2009 UNECE Regulation No 31	X	X	X	X	X	X					

25B	Filament lamps for use in approved lamp units of power-driven vehicles and their trailers	Regulation (EC) No 661/2009 UNECE Regulation No 37	X	X	X	X	X	X	X	X	X	X
25C	Motor vehicle headlamps equipped with gas-discharge light sources	Regulation (EC) No 661/2009 UNECE Regulation No 98	X	X	X	X	X	X				
25D	Gas-discharge light sources for use in approved gas-discharge lamp units of power-driven vehicles	Regulation (EC) No 661/2009 UNECE Regulation No 99	X	X	X	X	X	X				

25E	Motor vehicle headlamps emitting an asymmetrical passing beam or a driving beam or both and equipped with filament lamps and/or LED modules	Regulation (EC) No 661/2009 UNECE Regulation No 112	X	X	X	X	X	X				
25F	Adaptive front-lighting systems (AFS) for motor vehicles	Regulation (EC) No 661/2009 UNECE Regulation No 123	X	X	X	X	X	X				
26A	Power-driven vehicle front fog lamps	Regulation (EC) No 661/2009 UNECE Regulation No 19	X	X	X	X	X	X				
27A	Towing device	Regulation (EC) No 661/2009 Regulation (EU) No 1005/2010	A	A	A	A	A	A				

28A	Rear fog lamps for power-driven vehicles and their trailers	Regulation (EC) No 661/2009 UNECE Regulation No 38	X	X	X	X	X	X	X	X	X	X
29A	Reversing lights for power-driven vehicles and their trailers	Regulation (EC) No 661/2009 UNECE Regulation No 23	X	X	X	X	X	X	X	X	X	X
30A	Parking lamps for power-driven vehicles	Regulation (EC) No 661/2009 UNECE Regulation No 77	X	X	X	X	X	X				

31A	Safety-belts, restraint systems, child restraint systems and Isofix child restraint systems	Regulation (EC) No 661/2009 UNECE Regulation No 16	A	A	A	A	A	A				
32A	Forward field of vision	Regulation (EC) No 661/2009 UNECE Regulation No 125	S									
33A	Location and identification of hand controls, tell-tales and indicators	Regulation (EC) No 661/2009 UNECE Regulation No 121	X	X	X	X	X	X				
34A	Windscreen defrosting and demisting systems	Regulation (EC) No 661/2009 Regulation (EU) No 672/2010	A	(⁵)	(⁶)	(⁵)	(⁶)	(⁵)				

35A	Windscreen wiper and washer systems	Regulation (EC) No 661/2009 Regulation (EU) No 1008/2010	A	(6)	(6)	(6)	(6)	(6)					
36A	Heating systems	Regulation (EC) No 661/2009 UNECE Regulation No 122	X	X	X	X	X	X	X	X	X	X	X
37A	Wheel guards	Regulation (EC) No 661/2009 Regulation (EU) No 1009/2010	X										
38A	Head restraints (headrests), whether or not incorporated in vehicle seats	Regulation (EC) No 661/2009 UNECE Regulation No 25	X										

41A	Emissions (Euro VI) heavy duty vehicles/access to information	Regulation (EC) No 595/2009	X ⁽⁹⁾	X ⁽⁹⁾	X	X ⁽⁹⁾	X ⁽⁹⁾	X				
42A	Lateral protection of goods vehicles	Regulation (EC) No 661/2009 UNECE Regulation No 73					X	X			X	X
43A	Spray suppression systems	Regulation (EC) No 661/2009 Regulation (EU) No 109/2011				X	X	X	X	X	X	X
44A	Masses and dimensions	Regulation (EC) No 661/2009 Regulation (EU) No 1230/2012	X									
45A	Safety glazing materials and their installation on vehicles	Regulation (EC) No 661/2009 UNECE Regulation No 43	N/A	N/A	N/A	N/A	N/A	N/A	N/A	N/A	N/A	N/A
46	Tyres	Directive 92/23/EEC	A	A	A	A	A	A	A	A	A	A

46A	Installation of tyres	Regulation (EC) No 661/2009 Regulation (EU) No 458/2011	A	A	A	A	A	A	A	A	A	A
46B	Pneumatic tyres for motor vehicles and their trailers (Class C1)	Regulation (EC) No 661/2009 UNECE Regulation No 30	A			A			A	A		
46C	Pneumatic tyres for commercial vehicles and their trailers (Classes C2 and C3)	Regulation (EC) No 661/2009 UNECE Regulation No 54		A	A	A	A	A			A	A
46D	Tyre rolling sound emissions, adhesion on wet surfaces and rolling resistance (Classes C1, C2 and C3)	Regulation (EC) No 661/2009 UNECE Regulation No 117	A	A	A	A	A	A	A	A	A	A

46E	Temporary-use spare unit, run-flat tyres/system and tyre pressure monitoring system	Regulation (EC) No 661/2009 UNECE Regulation No 64	A ^(9A)			A ^(9A)						
47A	Speed limitation of vehicles	Regulation (EC) No 661/2009 UNECE Regulation No 89		X	X		X	X				
48A	Masses and dimensions	Regulation (EC) No 661/2009 Regulation (EU) No 1230/2012		X	X	X	X	X	X	X	X	X
49A	Commercial vehicles with regard to their external projections forward of the cab's rear panel	Regulation (EC) No 661/2009 UNECE Regulation No 61				A	A	A				
50A	Mechanical coupling components of combinations of vehicles	Regulation (EC) No 661/2009 UNECE Regulation No 55	X ⁽¹⁰⁾	X ⁽¹⁰⁾	X ⁽¹⁰⁾	X ⁽¹⁰⁾	X ⁽¹⁰⁾	X ⁽¹⁰⁾	X	X	X	X

50B	Close-coupling device (CCD); fitting of an approved type of CCD	Regulation (EC) No 661/2009 UNECE Regulation No 102					X ⁽¹⁰⁾	X ⁽¹⁰⁾			X ⁽¹⁰⁾	X ⁽¹⁰⁾
51A	Burning behaviour of materials used in the interior construction of certain categories of motor vehicles	Regulation (EC) No 661/2009 UNECE Regulation No 118			X							
52A	M ₂ and M ₃ vehicles	Regulation (EC) No 661/2009 UNECE Regulation No 107		A	A							

52B	Strength of the superstructure of large passenger vehicles	Regulation (EC) No 661/2009 UNECE Regulation No 66		A	A								
53A	Protection of occupants in the event of a frontal collision	Regulation (EC) No 661/2009 UNECE Regulation No 94	N/A										
54A	Protection of occupants in the event of lateral collision	Regulation (EC) No 661/2009 UNECE Regulation No 95	N/A			N/A							
55	(empty)												
56A	Vehicles for the carriage of dangerous goods	Regulation (EC) No 661/2009 UNECE Regulation No 105				X ⁽¹³⁾	X ⁽¹³⁾	X ⁽¹³⁾	X ⁽¹³⁾	X ⁽¹³⁾	X ⁽¹³⁾	X ⁽¹³⁾	X ⁽¹³⁾

57A	Front underrun protective devices (FUPDs) and their installation; front underrun protection (FUP)	Regulation (EC) No 661/2009 UNECE Regulation No 93					X	X				
58	Pedestrian protection	Regulation (EC) No 78/2009	N/A			N/A						
59	Recyclability	Directive 2005/64/EC	N/A			N/A						
60	(empty)											
61	Air-conditioning system	Directive 2006/40/EC	X			X ⁽¹⁴⁾						
62	Hydrogen system	Regulation (EC) No 79/2009	A	A	A	A	A	A				

63	General Safety	Regulation (EC) No 661/2009	X ⁽¹⁵⁾	X ⁽¹⁵⁾	X ⁽¹⁵⁾	X ⁽¹⁵⁾	X ⁽¹⁵⁾	X ⁽¹⁵⁾	X ⁽¹⁵⁾	X ⁽¹⁵⁾	X ⁽¹⁵⁾	X ⁽¹⁵⁾
64	Gear shift indicators	Regulation (EC) No 661/2009 Regulation (EU) No 65/2012	X									
65	Advanced emergency braking system	Regulation (EC) No 661/2009 Regulation (EU) No 347/2012		(¹⁶)	(¹⁶)		(¹⁶)	(¹⁶)				
66	Lane departure warning system	Regulation (EC) No 661/2009 Regulation (EU) No 351/2012		(¹⁷)	(¹⁷)		(¹⁷)	(¹⁷)				
67	Specific components for liquefied petroleum gases (LPG) and their installation on motor vehicles	Regulation (EC) No 661/2009 UNECE Regulation No 67	X	X	X	X	X	X				

68	Vehicle alarm systems (VAS)	Regulation (EC) No 661/2009 UNECE Regulation No 97	X			X							
69	Electrical safety	Regulation (EC) No 661/2009 UNECE Regulation No 100	X	X	X	X	X	X					
70	Specific components for CNG and their installation on motor vehicles	Regulation (EC) No 661/2009 UNECE Regulation No 110	X	X	X	X	X	X					
72	eCall system	Regulation (EU) 2015/758	G	N/A	N/A	G	N/A	N/A	N/A	N/A	N/A	N/A	N/A

Appendix 3

Wheelchair accessible vehicles

Item	Subject	Regulatory act	M ₁
1A	Sound level	Regulation (EU) No 540/2014	G+W ₉
2	Emissions (Euro 5 and 6) light duty vehicles/access to information	Regulation (EC) No 715/2007	G+W ₁
3A	Prevention of fire risks (liquid fuel tanks)	Regulation (EC) No 661/2009 UNECE Regulation No 34	X+W ₂
3B	Rear underrun protective devices (RUPDs) and their installation; rear underrun protection (RUP)	Regulation (EC) No 661/2009 UNECE Regulation No 58	X
4A	Space for mounting and fixing rear registration plates	Regulation (EC) No 661/2009 Regulation (EU) No 1003/2010	X
5A	Steering equipment	Regulation (EC) No 661/2009 UNECE Regulation No 79	G
6A	Vehicle access and manoeuvrability	Regulation (EC) No 661/2009 Regulation (EU) No 130/2012	X
6B	Door latches and door retention components	Regulation (EC) No 661/2009 UNECE Regulation No 11	X
7A	Audible warning devices and signals	Regulation (EC) No 661/2009 UNECE Regulation No 28	X
8A	Devices for indirect vision and their installation	Regulation (EC) No 661/2009 UNECE Regulation No 46	X

9B	Braking of passenger cars	Regulation (EC) No 661/2009 UNECE Regulation No 13-H	G+A ₁
10A	Electromagnetic compatibility	Regulation (EC) No 661/2009 UNECE Regulation No 10	X
12A	Interior fittings	Regulation (EC) No 661/2009 UNECE Regulation No 21	G+C
13B	Protection of motor vehicles against unauthorised use	Regulation (EC) No 661/2009 UNECE Regulation No 116	X
14A	Protection of the driver against the steering mechanism in the event of impact	Regulation (EC) No 661/2009 UNECE Regulation No 12	G
15A	Seats, their anchorages and any head restraints	Regulation (EC) No 661/2009 UNECE Regulation No 17	G+W ₃
16A	External projections	Regulation (EC) No 661/2009 UNECE Regulation No 26	G+W ₄
17A	Vehicle access and manoeuvrability	Regulation (EC) No 661/2009 Regulation (EU) No 130/2012	X
17B	Speedometer equipment including its installation	Regulation (EC) No 661/2009 UNECE Regulation No 39	X
18A	Manufacturer's statutory plate and vehicle identification number	Regulation (EC) No 661/2009 Regulation (EU) No 19/2011	X
19A	Safety-belt anchorages, Isofix anchorages systems and Isofix top tether anchorages	Regulation (EC) No 661/2009 UNECE Regulation No 14	X+W ₅

20A	Installation of lighting and light-signalling devices on vehicles	Regulation (EC) No 661/2009 UNECE Regulation No 48	X
21A	Retro-reflecting devices for power-driven vehicles and their trailers	Regulation (EC) No 661/2009 UNECE Regulation No 3	X
22A	Front and rear position lamps, stop-lamps and end-outline marker lamps for motor vehicles and their trailers	Regulation (EC) No 661/2009 UNECE Regulation No 7	X
22B	Daytime running lamps for power-driven vehicles	Regulation (EC) No 661/2009 UNECE Regulation No 87	X
22C	Side-marker lamps for motor vehicles and their trailers	Regulation (EC) No 661/2009 UNECE Regulation No 91	X
23A	Direction indicators for power-driven vehicles and their trailers	Regulation (EC) No 661/2009 UNECE Regulation No 6	X
24A	Illumination of rear-registration plates of power-driven vehicles and their trailers	Regulation (EC) No 661/2009 UNECE Regulation No 4	X
25A	Power-driven vehicle's sealed-beam headlamps (SB) emitting an European asymmetrical passing beam or a driving beam or both	Regulation (EC) No 661/2009 UNECE Regulation No 31	X
25B	Filament lamps for use in approved lamp units of power-driven vehicles and their trailers	Regulation (EC) No 661/2009 UNECE Regulation No 37	X
25C	Motor vehicle headlamps equipped with gas-discharge light sources	Regulation (EC) No 661/2009 UNECE Regulation No 98	X

25D	Gas-discharge light sources for use in approved gas-discharge lamp units of power-driven vehicles	Regulation (EC) No 661/2009 UNECE Regulation No 99	X
25E	Motor vehicle headlamps emitting an asymmetrical passing beam or a driving beam or both and equipped with filament lamps and/or LED modules	Regulation (EC) No 661/2009 UNECE Regulation No 112	X
25F	Adaptive front-lighting systems (AFS) for motor vehicles	Regulation (EC) No 661/2009 UNECE Regulation No 123	X
26A	Power-driven vehicle front fog lamps	Regulation (EC) No 661/2009 UNECE Regulation No 19	X
27A	Towing device	Regulation (EC) No 661/2009 Regulation (EU) No 1005/2010	E
28A	Rear fog lamps for power-driven vehicles and their trailers	Regulation (EC) No 661/2009 UNECE Regulation No 38	X
29A	Reversing lights for power-driven vehicles and their trailers	Regulation (EC) No 661/2009 UNECE Regulation No 23	X
30A	Parking lamps for power-driven vehicles	Regulation (EC) No 661/2009 UNECE Regulation No 77	X
31A	Safety-belts, restraint systems, child restraint systems and Isofix child restraint systems	Regulation (EC) No 661/2009 UNECE Regulation No 16	X+W ₆
32A	Forward field of vision	Regulation (EC) No 661/2009 UNECE Regulation No 125	G
33A	Location and identification of hand controls, tell-tales and indicators	Regulation (EC) No 661/2009 UNECE Regulation No 121	X

34A	Windscreen defrosting and demisting systems	Regulation (EC) No 661/2009 Regulation (EU) No 672/2010	G ⁽⁵⁾
35A	Windscreen wiper and washer systems	Regulation (EC) No 661/2009 Regulation (EU) No 1008/2010	G ⁽⁶⁾
36A	Heating systems	Regulation (EC) No 661/2009 UNECE Regulation No 122	X
37A	Wheel guards	Regulation (EC) No 661/2009 Regulation (EU) No 1009/2010	G
38A	Head restraints (headrests), whether or not incorporated in vehicle seats	Regulation (EC) No 661/2009 UNECE Regulation No 25	X
41A	Emissions (Euro VI) heavy duty vehicles/access to information	Regulation (EC) No 595/2009	X+W ₁ (⁹)
44A	Masses and dimensions	Regulation (EC) No 661/2009 Regulation (EU) No 1230/2012	X+W ₈
45A	Safety glazing materials and their installation on vehicles	Regulation (EC) No 661/2009 UNECE Regulation No 43	G
46	Tyres	Directive 92/23/EEC	X
46A	Installation of tyres	Regulation (EC) No 661/2009 Regulation (EU) No 458/2011	X
46B	Pneumatic tyres for motor vehicles and their trailers (Class C1)	Regulation (EC) No 661/2009 UNECE Regulation No 30	X
46D	Tyre rolling sound emissions, adhesion on wet surfaces and rolling resistance (Classes C1, C2 and C3)	Regulation (EC) No 661/2009 UNECE Regulation No 117	X

46E	Temporary-use spare unit, run-flat tyres/system and tyre pressure monitoring system	Regulation (EC) No 661/2009 UNECE Regulation No 64	G ^(9A)
50A	Mechanical coupling components of combinations of vehicles	Regulation (EC) No 661/2009 UNECE Regulation No 55	X ⁽¹⁰⁾
53A	Protection of occupants in the event of a frontal collision	Regulation (EC) No 661/2009 UNECE Regulation No 94	N/A
54A	Protection of occupants in the event of lateral collision	Regulation (EC) No 661/2009 UNECE Regulation No 95	N/A
58	Pedestrian protection	Regulation (EC) No 78/2009	G
59	Recyclability	Directive 2005/64/EC	N/A
61	Air-conditioning systems	Directive 2006/40/EC	G
62	Hydrogen system	Regulation (EC) No 79/2009	X
63	General Safety	Regulation (EC) No 661/2009	X ⁽¹⁵⁾
64	Gear shift indicators	Regulation (EC) No 661/2009 Regulation (EU) No 65/2012	G
67	Specific components for liquefied petroleum gases (LPG) and their installation on motor vehicles	Regulation (EC) No 661/2009 UNECE Regulation No 67	X
68	Vehicle alarm systems (VAS)	Regulation (EC) No 661/2009 UNECE Regulation No 97	X
69	Electric safety	Regulation (EC) No 661/2009 UNECE Regulation No 100	X
70	Specific components for CNG and their installation on motor vehicles	Regulation (EC) No 661/2009 UNECE Regulation No 110	X
72	eCall system	Regulation (EU) 2015/758	G

Additional requirements for testing the wheelchair tie down and occupant restraint system

The following section 1 and either section 2 or 3 shall apply.

1. Definitions

- 1.1. Surrogate wheelchair (SWC) means a rigid, re-usable test wheelchair, as defined in section 3 of ISO 10542-1:2012.
- 1.2. Point P means a representation of the position of the wheelchair occupant's hip when seated in the SWC, as defined in section 3 of ISO 10542-1:2012.

2. General requirements

- 2.1. Each wheelchair location shall be provided with anchorages to which a wheelchair tie-down and occupant restraint system (WTORS) shall be fitted.
- 2.2. The wheelchair occupant's lower belt anchorages shall be located in accordance with UNECE Regulation No 14-07, paragraph 5.4.2.2, relative to Point P on the SWC, when placed in the travelling position designated by the manufacturer. The upper actual anchorage(s) shall be located at least 1 100 mm above the horizontal plane passing through the points of contact between the rear tyres of the SWC and the vehicle floor. This condition shall still be satisfied after the test carried out according to point 3 of this Appendix.
- 2.3. An assessment shall be made of the WTORS occupant belt to ensure compliance with the provisions of UNECE Regulation No 16-06, paragraphs 8.2.2 to 8.2.2.4 and 8.3.1 to 8.3.4.
- 2.4. The minimum number of ISOFIX child seat anchorages need not to be provided. In the case of a multi-stage type-approval where an ISOFIX anchorage system has been affected by the conversion, either the system shall be re-tested or the anchorages shall be rendered unusable. In the latter case the ISOFIX labels shall be removed and appropriate information shall be given to the vehicle purchaser.

3. Static in-vehicle testing

3.1. Wheelchair occupant restraint anchorages

3.1.1. The wheelchair occupant restraint anchorages shall resist the static forces prescribed for occupant restraint anchorages in UNECE Regulation No 14-07, simultaneously with the static forces applied to the wheelchair tie-down anchorages as specified in point 3.2 of this Appendix.

3.2. Wheelchair tie-down anchorages

The wheelchair tie-down anchorages shall resist the following forces, for at least 0.2 seconds, applied via the SWC (or a suitable surrogate wheelchair having a wheelbase, seat height and tie-down attachment points in accordance with the specification for the SWC), at a height of 300 +/- 100 mm from the surface on which the SWC rests:

3.2.1. In the case of a forward-facing wheelchair, a simultaneous force, coincident with the force applied to the occupant restraint anchorages, of 24,5 kN, and

3.2.2. a second test applying a static force of 8,2 kN directed towards the rear of the vehicle.

3.2.3. In the case of a rearward-facing wheelchair, a simultaneous force, coincident with the force applied to the occupant restraint anchorages, of 8,2 kN, and

3.2.4. a second test applying a static force of 24,5 kN directed towards the front of the vehicle

3.3. Components of the system

3.3.1. All components of the WTORS shall meet the relevant requirements of ISO 10542-1:2012.

However, the dynamic test specified in Annex A and paragraphs 5.2.2 and 5.2.3 of ISO 10542-1:2012 shall be carried out on the complete WTORS using the vehicle anchorage geometry instead of the test geometry specified in Annex A of ISO 10542-1:2012. This may be carried out within the vehicle structure or on a surrogate structure representative of the vehicle's WTORS anchorage geometry. The location of each anchorage shall lie within the tolerance provided for in paragraph 7.7.1 of UNECE Regulation No 16-06.

3.3.2. Where the occupant restraint part of the WTORS is approved according to UNECE Regulation No 16-06, it shall be subject to the dynamic test of the complete WTORS specified in paragraph 3.3.1 of this appendix but the requirements of paragraphs 5.1, 5.3 and 5.4 of ISO10542-1:2012 shall be considered to have been met

4. Dynamic in-vehicle testing

4.1. The full assembly of the WTORS system shall be tested by an in-vehicle dynamic test in accordance with paragraphs 5.2.2 and 5.2.3 and Annex A of ISO 10542-1:2012, testing all components/anchorages simultaneously, using a vehicle body-in-white or representative structure.

4.2. The component parts of the WTORS shall meet the relevant requirements of ISO10542-1:2012, paragraphs 5.1, 5.3 and 5.4. These requirements shall be deemed to have been met in respect of the occupant restraint if it is approved according to UNECE Regulation No 16-06.

Appendix 4

Other special purpose vehicles
(including special group, multi-equipment carrier and trailer caravans)

The exemptions provided for in this appendix are only permitted if the manufacturer demonstrates to the satisfaction of the approval authority that the vehicle, due to the special function, cannot meet all the requirements set out in Part I of Annex IV.

Item	Subject	Reference to regulatory act	M ₂	M ₃	N ₁	N ₂	N ₃	O ₁	O ₂	O ₃	O ₄
1A	Sound level	Regulation (EU) No 540/2014		H	H	H	H	H			
2	Emissions (Euro 5 and 6) light duty vehicles/access to information	Regulation (EC) No 715/2007	Q ⁽¹⁾		Q+V ₁ (¹)	Q+V ₁ (¹)					
3A	Prevention of fire risks (liquid fuel tanks)	Regulation (EC) No 661/2009 UNECE Regulation No 34	F	F	F	F	F	X	X	X	X
3B	Rear underrun protective devices (RUPDs) and their installation; rear underrun protection (RUP)	Regulation (EC) No 661/2009 UNECE Regulation No 58	X	X	A	A	A	X	X	X	X

4A	Space for mounting and fixing rear registration plates	Regulation (EC) No 661/2009 Regulation (EU) No 1003/2010	A+R	A+R	A+R	A+R	A+R	A+R	A+R	A+R	A+R	A+R
5A	Steering equipment	Regulation (EC) No 661/2009 UNECE Regulation No 79	X	X	X	X	X	X	X	X	X	X
6A	Vehicle access and manoeuvrability	Regulation (EC) No 661/2009 Regulation (EU) No 130/2012	X	X	B	B	B					
6B	Door latches and door retention components	Regulation (EC) No 661/2009 UNECE Regulation No 11			B							
7A	Audible warning devices and signals	Regulation (EC) No 661/2009 UNECE Regulation No 28	X	X	X	X	X					
8A	Devices for indirect vision and their installation	Regulation (EC) No 661/2009 UNECE Regulation No 46	X	X	X	X	X					

9A	Braking of vehicles and trailers	Regulation (EC) No 661/2009 UNECE Regulation No 13	X ⁽³⁾	X ⁽³⁾	X ⁽³⁾	X+U ₁ ⁽³⁾	X+U ₁ ⁽³⁾	X	X	X ⁽³⁾	X ⁽³⁾
9B	Braking of passenger cars	Regulation (EC) No 661/2009 UNECE Regulation No 13-H			X ⁽⁴⁾						
10A	Electromagnetic compatibility	Regulation (EC) No 661/2009 UNECE Regulation No 10	X	X	X	X	X	X	X	X	X
13A	Protection of motor vehicles against unauthorised use	Regulation (EC) No 661/2009 UNECE Regulation No 18	X ^(4A)	X ^(4A)		X ^(4A)	X ^(4A)				
13B	Protection of motor vehicles against unauthorised use	Regulation (EC) No 661/2009 UNECE Regulation No 116			X						
14A	Protection of the driver against the steering mechanism in the event of impact	Regulation (EC) No 661/2009 UNECE Regulation No 12			X						

15A	Seats, their anchorages and any head restraints	Regulation (EC) No 661/2009 UNECE Regulation No 17	D ^(4B)	D ^(4B)	D	D	D				
15B	Seats of large passenger vehicles	Regulation (EC) No 661/2009 UNECE Regulation No 80	D	D							
17A	Vehicle access and manoeuvrability	Regulation (EC) No 661/2009 Regulation (EU) No 130/2012	X	X	X	X	X				
17B	Speedometer equipment including its installation	Regulation (EC) No 661/2009 UNECE Regulation No 39	X	X	X	X	X				
18A	Manufacturer's statutory plate and vehicle identification number	Regulation (EC) No 661/2009 Regulation (EU) No 19/2011	X	X	X	X	X	X	X	X	X
19A	Safety-belt anchorages, Isofix anchorages systems and Isofix top tether anchorages	Regulation (EC) No 661/2009 UNECE Regulation No 14	D	D	D	D	D				

20A	Installation of lighting and light-signalling devices on vehicles	Regulation (EC) No 661/2009 UNECE Regulation No 48	A+N	A+N	A+N	A+N	A+N	A+N	A+N	A+N	A+N	A+N
21A	Retro-reflecting devices for power-driven vehicles and their trailers	Regulation (EC) No 661/2009 UNECE Regulation No 3	X	X	X	X	X	X	X	X	X	X
22A	Front and rear position lamps, stop-lamps and end-outline marker lamps for motor vehicles and their trailers	Regulation (EC) No 661/2009 UNECE Regulation No 7	X	X	X	X	X	X	X	X	X	X
22B	Daytime running lamps for power-driven vehicles	Regulation (EC) No 661/2009 UNECE Regulation No 87	X	X	X	X	X					
22C	Side-marker lamps for motor vehicles and their trailers	Regulation (EC) No 661/2009 UNECE Regulation No 91	X	X	X	X	X	X	X	X	X	X
23A	Direction indicators for power-driven vehicles and their trailers	Regulation (EC) No 661/2009 UNECE Regulation No 6	X	X	X	X	X	X	X	X	X	X

24A	Illumination of rear-registration plates of power-driven vehicles and their trailers	Regulation (EC) No 661/2009 UNECE Regulation No 4	X	X	X	X	X	X	X	X	X	X
25A	Power-driven vehicle's sealed-beam headlamps (SB) emitting an European asymmetrical passing beam or a driving beam or both	Regulation (EC) No 661/2009 UNECE Regulation No 31	X	X	X	X	X					
25B	Filament lamps for use in approved lamp units of power-driven vehicles and their trailers	Regulation (EC) No 661/2009 UNECE Regulation No 37	X	X	X	X	X	X	X	X	X	X
25C	Motor vehicle headlamps equipped with gas-discharge light sources	Regulation (EC) No 661/2009 UNECE Regulation No 98	X	X	X	X	X					
25D	Gas-discharge light sources for use in approved gas-discharge lamp units of power-driven vehicles	Regulation (EC) No 661/2009 UNECE Regulation No 99	X	X	X	X	X					
25E	Motor vehicle headlamps emitting an asymmetrical passing beam or a driving beam or both and equipped with filament lamps and/or LED modules	Regulation (EC) No 661/2009 UNECE Regulation No 112	X	X	X	X	X					

25F	Adaptive front-lighting systems (AFS) for motor vehicles	Regulation (EC) No 661/2009 UNECE Regulation No 123	X	X	X	X	X				
26A	Power-driven vehicle front fog lamps	Regulation (EC) No 661/2009 UNECE Regulation No 19	X	X	X	X	X				
27A	Towing device	Regulation (EC) No 661/2009 Regulation (EU) No 1005/2010	A	A	A	A	A				
28A	Rear fog lamps for power-driven vehicles and their trailers	Regulation (EC) No 661/2009 UNECE Regulation No 38	X	X	X	X	X	X	X	X	X
29A	Reversing lights for power-driven vehicles and their trailers	Regulation (EC) No 661/2009 UNECE Regulation No 23	X	X	X	X	X	X	X	X	X
30A	Parking lamps for power-driven vehicles	Regulation (EC) No 661/2009 UNECE Regulation No 77	X	X	X	X	X				

31A	Safety-belts, restraint systems, child restraint systems and Isofix child restraint systems	Regulation (EC) No 661/2009 UNECE Regulation No 16	D	D	D	D	D				
33A	Location and identification of hand controls, tell-tales and indicators	Regulation (EC) No 661/2009 UNECE Regulation No 121	X	X	X	X	X				
34A	Windscreen defrosting and demisting systems	Regulation (EC) No 661/2009 Regulation (EU) No 672/2010	(⁵)	(⁵)	(⁵)	(⁵)	(⁵)				
35A	Windscreen wiper and washer systems	Regulation (EC) No 661/2009 Regulation (EU) No 1008/2010	(⁶)	(⁶)	(⁶)	(⁶)	(⁶)				
36A	Heating systems	Regulation (EC) No 661/2009 UNECE Regulation No 122	X	X	X	X	X	X	X	X	X
38A	Head restraints (headrests), whether or not incorporated in vehicle seats	Regulation (EC) No 661/2009 UNECE Regulation No 25	X								
41A	Emissions (Euro VI) heavy duty vehicles/access to information	Regulation (EC) No 595/2009	H (⁹)	H	H (⁹)	H (⁹)	H				

42A	Lateral protection of goods vehicles	Regulation (EC) No 661/2009 UNECE Regulation No 73				X	X			X	X
43A	Spray suppression systems	Regulation (EC) No 661/2009 Regulation (EU) No 109/2011			X	X	X	X	X	X	X
45A	Safety glazing materials and their installation on vehicles	Regulation (EC) No 661/2009 UNECE Regulation No 43	J	J	J	J	J	J	J	J	J
46	Tyres	Directive 92/23/EEC	X	X	X	X	X	X	X	X	X
46A	Installation of tyres	Regulation (EC) No 661/2009 Regulation (EU) No 458/2011	X	X	X	X	X	X	X	X	X
46B	Pneumatic tyres for motor vehicles and their trailers (Class C1)	Regulation (EC) No 661/2009 UNECE Regulation No 30			X			X	X		
46C	Pneumatic tyres for commercial vehicles and their trailers (Classes C2 and C3)	Regulation (EC) No 661/2009 UNECE Regulation No 54	X	X	X	X	X			X	X

46D	Tyre rolling sound emissions, adhesion on wet surfaces and rolling resistance (Classes C1, C2 and C3)	Regulation (EC) No 661/2009 UNECE Regulation No 117	X	X	X	X	X	X	X	X	X	X
46E	Temporary-use spare unit, run-flat tyres/system and tyre pressure monitoring system	Regulation (EC) No 661/2009 UNECE Regulation No 64			X ^(9A)							
47A	Speed limitation of vehicles	Regulation (EC) No 661/2009 UNECE Regulation No 89	X	X		X	X					
48A	Masses and dimensions	Regulation (EC) No 661/2009 Regulation (EU) No 1230/2012	X	X	X	X	X	X	X	X	X	X
49A	Commercial vehicles with regard to their external projections forward of the cab's rear panel	Regulation (EC) No 661/2009 UNECE Regulation No 61			X	X	X					
50A	Mechanical coupling components of combinations of vehicles	Regulation (EC) No 661/2009 UNECE Regulation No 55	X ⁽¹⁰⁾	X ⁽¹⁰⁾	X ⁽¹⁰⁾	X ⁽¹⁰⁾	X ⁽¹⁰⁾	X	X	X	X	X

50B	Close-coupling device (CCD); fitting of an approved type of CCD	Regulation (EC) No 661/2009 UNECE Regulation No 102				X ⁽¹⁰⁾	X ⁽¹⁰⁾			X ⁽¹⁰⁾	X ⁽¹⁰⁾
51A	Burning behaviour of materials used in the interior construction of certain categories of motor vehicles	Regulation (EC) No 661/2009 UNECE Regulation No 118		X							
52A	M ₂ and M ₃ vehicles	Regulation (EC) No 661/2009 UNECE Regulation No 107	X	X							
52B	Strength of the superstructure of large passenger vehicles	Regulation (EC) No 661/2009 UNECE Regulation No 66	X	X							
54A	Protection of occupants in the event of lateral collision	Regulation (EC) No 661/2009 UNECE Regulation No 95			A						
56A	Vehicles for the carriage of dangerous goods	Regulation (EC) No 661/2009 UNECE Regulation No 105				X ⁽¹³⁾	X ⁽¹³⁾	X ⁽¹³⁾	X ⁽¹³⁾	X ⁽¹³⁾	X ⁽¹³⁾
57A	Front underrun protective devices (FUPDs) and their installation; front underrun protection (FUP)	Regulation (EC) No 661/2009 UNECE Regulation No 93				X	X				

58	Pedestrian protection	Regulation (EC) No 78/2009			N/A ⁽²⁾						
59	Recyclability	Directive 2005/64/EC			N/A						
61	Air-conditioning systems	Directive 2006/40/EC			X ⁽¹⁴⁾						
62	Hydrogen system	Regulation (EC) No 79/2009	X	X	X	X	X				
63	General Safety	Regulation (EC) No 661/2009	X ⁽¹⁵⁾	X ⁽¹⁵⁾	X ⁽¹⁵⁾	X ⁽¹⁵⁾	X ⁽¹⁵⁾	X ⁽¹⁵⁾	X ⁽¹⁵⁾	X ⁽¹⁵⁾	X ⁽¹⁵⁾
65	Advanced emergency braking system	Regulation (EC) No 661/2009 Regulation (EU) No 347/2012	N/A	N/A		N/A	N/A				
66	Lane departure warning system	Regulation (EC) No 661/2009 Regulation (EU) No 351/2012	N/A	N/A		N/A	N/A				
67	Specific components for liquefied petroleum gases (LPG) and their installation on motor vehicles	Regulation (EC) No 661/2009 UNECE Regulation No 67	X	X	X	X	X				

68	Vehicle alarm systems (VAS)	Regulation (EC) No 661/2009 UNECE Regulation No 97			X							
69	Electric safety	Regulation (EC) No 661/2009 UNECE Regulation No 100	X	X	X	X	X					
70	Specific components for CNG and their installation on motor vehicles	Regulation (EC) No 661/2009 UNECE Regulation No 110	X	X	X	X	X					
72	eCall system	Regulation (EU) 2015/758	N/A	N/A	G	N/A	N/A	N/A	N/A	N/A	N/A	N/A

Appendix 5

Mobile cranes

Item	Subject	Reference to regulatory act	N ₃
1A	Sound level	Regulation (EU) No 540/2014	T + Z ₁
3A	Prevention of fire risks (liquid fuel tanks)	Regulation (EC) No 661/2009 UNECE Regulation No 34	X
3B	Rear underrun protective devices (RUPDs) and their installation; rear underrun protection (RUP)	Regulation (EC) No 661/2009 UNECE Regulation No 58	A
4A	Space for mounting and fixing rear registration plates	Regulation (EC) No 661/2009 Regulation (EU) No 1003/2010	X
5A	Steering equipment	Regulation (EC) No 661/2009 UNECE Regulation No 79	X Crab steering allowed
6A	Vehicle access and manoeuvrability	Regulation (EC) No 661/2009 Regulation (EU) No 130/2012	A
7A	Audible warning devices and signals	Regulation (EC) No 661/2009 UNECE Regulation No 28	X
8A	Devices for indirect vision and their installation	Regulation (EC) No 661/2009 UNECE Regulation No 46	X
9A	Braking of vehicles and trailers	Regulation (EC) No 661/2009 UNECE Regulation No 13	U ⁽³⁾
10A	Electromagnetic compatibility	Regulation (EC) No 661/2009 UNECE Regulation No 10	X

13A	Protection of motor vehicles against unauthorised use	Regulation (EC) No 661/2009 UNECE Regulation No 18	X ^(4A)
15A	Seats, their anchorages and any head restraints	Regulation (EC) No 661/2009 UNECE Regulation No 17	X
17A	Vehicle access and manoeuvrability	Regulation (EC) No 661/2009 Regulation (EU) No 130/2012	X
17B	Speedometer equipment including its installation	Regulation (EC) No 661/2009 UNECE Regulation No 39	X
18A	Manufacturer's statutory plate and vehicle identification number	Regulation (EC) No 661/2009 Regulation (EU) No 19/2011	X
19A	Safety-belt anchorages, Isofix anchorages systems and Isofix top tether anchorages	Regulation (EC) No 661/2009 UNECE Regulation No 14	X
20A	Installation of lighting and light-signalling devices on vehicles	Regulation (EC) No 661/2009 UNECE Regulation No 48	A+Y
21A	Retro-reflecting devices for power-driven vehicles and their trailers	Regulation (EC) No 661/2009 UNECE Regulation No 3	X
22A	Front and rear position lamps, stop-lamps and end-outline marker lamps for motor vehicles and their trailers	Regulation (EC) No 661/2009 UNECE Regulation No 7	X
22B	Daytime running lamps for power-driven vehicles	Regulation (EC) No 661/2009 UNECE Regulation No 87	X
22C	Side-marker lamps for motor vehicles and their trailers	Regulation (EC) No 661/2009 UNECE Regulation No 91	X

23A	Direction indicators for power-driven vehicles and their trailers	Regulation (EC) No 661/2009 UNECE Regulation No 6	X
24A	Illumination of rear-registration plates of power-driven vehicles and their trailers	Regulation (EC) No 661/2009 UNECE Regulation No 4	X
25A	Power-driven vehicle's sealed-beam headlamps (SB) emitting an European asymmetrical passing beam or a driving beam or both	Regulation (EC) No 661/2009 UNECE Regulation No 31	X
25B	Filament lamps for use in approved lamp units of power-driven vehicles and their trailers	Regulation (EC) No 661/2009 UNECE Regulation No 37	X
25C	Motor vehicle headlamps equipped with gas-discharge light sources	Regulation (EC) No 661/2009 UNECE Regulation No 98	X
25D	Gas-discharge light sources for use in approved gas-discharge lamp units of power-driven vehicles	Regulation (EC) No 661/2009 UNECE Regulation No 99	X
25E	Motor vehicle headlamps emitting an asymmetrical passing beam or a driving beam or both and equipped with filament lamps and/or LED modules	Regulation (EC) No 661/2009 UNECE Regulation No 112	X
25F	Adaptive front-lighting systems (AFS) for motor vehicles	Regulation (EC) No 661/2009 UNECE Regulation No 123	X
26A	Power-driven vehicle front fog lamps	Regulation (EC) No 661/2009 UNECE Regulation No 19	X
27A	Towing device	Regulation (EC) No 661/2009 Regulation (EU) No 1005/2010	A
28A	Rear fog lamps for power-driven vehicles and their trailers	Regulation (EC) No 661/2009 UNECE Regulation No 38	X

29A	Reversing lights for power-driven vehicles and their trailers	Regulation (EC) No 661/2009 UNECE Regulation No 23	X
30A	Parking lamps for power-driven vehicles	Regulation (EC) No 661/2009 UNECE Regulation No 77	X
31A	Safety-belts, restraint systems, child restraint systems and Isofix child restraint systems	Regulation (EC) No 661/2009 UNECE Regulation No 16	X
33A	Location and identification of hand controls, tell-tales and indicators	Regulation (EC) No 661/2009 UNECE Regulation No 121	X
34A	Windscreen defrosting and demisting systems	Regulation (EC) No 661/2009 Regulation (EU) No 672/2010	(⁵)
35A	Windscreen wiper and washer systems	Regulation (EC) No 661/2009 Regulation (EU) No 1008/2010	(⁶)
36A	Heating systems	Regulation (EC) No 661/2009 UNECE Regulation No 122	X
41A	Emissions (Euro VI) heavy duty vehicles/access to information	Regulation (EC) No 595/2009	V
42A	Lateral protection of goods vehicles	Regulation (EC) No 661/2009 UNECE Regulation No 73	A
43A	Spray suppression systems	Regulation (EC) No 661/2009 Regulation (EU) No 109/2011	Z ₁
45A	Safety glazing materials and their installation on vehicles	Regulation (EC) No 661/2009 UNECE Regulation No 43	J

46	Tyres	Directive 92/23/EEC	X
46A	Installation of tyres	Regulation (EC) No 661/2009 Regulation (EU) No 458/2011	X
46C	Pneumatic tyres for commercial vehicles and their trailers (Classes C2 and C3)	Regulation (EC) No 661/2009 UNECE Regulation No 54	X
46D	Tyre rolling sound emissions, adhesion on wet surfaces and rolling resistance (Classes C1, C2 and C3)	Regulation (EC) No 661/2009 UNECE Regulation No 117	X
47A	Speed limitation of vehicles	Regulation (EC) No 661/2009 UNECE Regulation No 89	X
48A	Masses and dimensions	Regulation (EC) No 661/2009 Regulation (EU) No 1230/2012	A
49A	Commercial vehicles with regard to their external projections forward of the cab's rear panel	Regulation (EC) No 661/2009 UNECE Regulation No 61	A
50A	Mechanical coupling components of combinations of vehicles	Regulation (EC) No 661/2009 UNECE Regulation No 55	X ⁽¹⁰⁾
50B	Close-coupling device (CCD); fitting of an approved type of CCD	Regulation (EC) No 661/2009 UNECE Regulation No 102	X ⁽¹⁰⁾
57A	Front underrun protective devices (FUPDs) and their installation; front underrun protection (FUP)	Regulation (EC) No 661/2009 UNECE Regulation No 93	X

62	Hydrogen system	Regulation (EC) No 79/2009	X
63	General Safety	Regulation (EC) No 661/2009	X ⁽¹⁵⁾
65	Advanced emergency braking system	Regulation (EC) No 661/2009 Regulation (EU) No 347/2012	N/A ⁽¹⁶⁾
66	Lane departure warning system	Regulation (EC) No 661/2009 Regulation (EU) No 351/2012	N/A ⁽¹⁷⁾
67	Specific components for liquefied petroleum gases (LPG) and their installation on motor vehicles	Regulation (EC) No 661/2009 UNECE Regulation No 67	X
69	Electric safety	Regulation (EC) No 661/2009 UNECE Regulation No 100	X
70	Specific components for CNG and their installation on motor vehicles	Regulation (EC) No 661/2009 UNECE Regulation No 110	X

Appendix 6

Exceptional load transport trailers

Item	Subject	Reference to regulatory act	N ₃	O ₄
1	Permissible sound level	Directive 70/157/EEC	T	
3A	Prevention of fire risks (liquid fuel tanks)	Regulation (EC) No 661/2009 UNECE Regulation No 34	X	X
3B	Rear underrun protective devices (RUPDs) and their installation; rear underrun protection (RUP)	Regulation (EC) No 661/2009 UNECE Regulation No 58	A	A
4A	Space for mounting and fixing rear registration plates	Regulation (EC) No 661/2009 Regulation (EU) No 1003/2010	X	A+R
5A	Steering equipment	Regulation (EC) No 661/2009 UNECE Regulation No 79	X Crab steering allowed	X
6A	Vehicle access and manoeuvrability	Regulation (EC) No 661/2009 Regulation (EU) No 130/2012	X	
7A	Audible warning devices and signals	Regulation (EC) No 661/2009 UNECE Regulation No 28	X	
8A	Devices for indirect vision and their installation	Regulation (EC) No 661/2009 UNECE Regulation No 46	X	
9A	Braking of vehicles and trailers	Regulation (EC) No 661/2009 UNECE Regulation No 13	U ⁽³⁾	X ⁽³⁾

10A	Electromagnetic compatibility	Regulation (EC) No 661/2009 UNECE Regulation No 10	X	X
13A	Protection of motor vehicles against unauthorised use	Regulation (EC) No 661/2009 UNECE Regulation No 18	X ^(4A)	
15A	Seats, their anchorages and any head restraints	Regulation (EC) No 661/2009 UNECE Regulation No 17	X	
17A	Vehicle access and manoeuvrability	Regulation (EC) No 661/2009 Regulation (EU) No 130/2012	X	
17B	Speedometer equipment including its installation	Regulation (EC) No 661/2009 UNECE Regulation No 39	X	
18A	Manufacturer's statutory plate and vehicle identification number	Regulation (EC) No 661/2009 Regulation (EU) No 19/2011	X	X
19A	Safety-belt anchorages, Isofix anchorages systems and Isofix top tether anchorages	Regulation (EC) No 661/2009 UNECE Regulation No 14	X	
20A	Installation of lighting and light-signalling devices on vehicles	Regulation (EC) No 661/2009 UNECE Regulation No 48	X	A+N
21A	Retro-reflecting devices for power-driven vehicles and their trailers	Regulation (EC) No 661/2009 UNECE Regulation No 3	X	X
22A	Front and rear position lamps, stop-lamps and end-outline marker lamps for motor vehicles and their trailers	Regulation (EC) No 661/2009 UNECE Regulation No 7	X	X
22B	Daytime running lamps for power-driven vehicles	Regulation (EC) No 661/2009 UNECE Regulation No 87	X	

22C	Side-marker lamps for motor vehicles and their trailers	Regulation (EC) No 661/2009 UNECE Regulation No 91	X	X
23A	Direction indicators for power-driven vehicles and their trailers	Regulation (EC) No 661/2009 UNECE Regulation No 6	X	X
24A	Illumination of rear-registration plates of power-driven vehicles and their trailers	Regulation (EC) No 661/2009 UNECE Regulation No 4	X	X
25A	Power-driven vehicle's sealed-beam headlamps (SB) emitting an European asymmetrical passing beam or a driving beam or both	Regulation (EC) No 661/2009 UNECE Regulation No 31	X	
25B	Filament lamps for use in approved lamp units of power-driven vehicles and their trailers	Regulation (EC) No 661/2009 UNECE Regulation No 37	X	X
25C	Motor vehicle headlamps equipped with gas-discharge light sources	Regulation (EC) No 661/2009 UNECE Regulation No 98	X	
25D	Gas-discharge light sources for use in approved gas-discharge lamp units of power-driven vehicles	Regulation (EC) No 661/2009 UNECE Regulation No 99	X	
25E	Motor vehicle headlamps emitting an asymmetrical passing beam or a driving beam or both and equipped with filament lamps and/or LED modules	Regulation (EC) No 661/2009 UNECE Regulation No 112	X	
25F	Adaptive front-lighting systems (AFS) for motor vehicles	Regulation (EC) No 661/2009 UNECE Regulation No 123	X	
26A	Power-driven vehicle front fog lamps	Regulation (EC) No 661/2009 UNECE Regulation No 19	X	

27A	Towing device	Regulation (EC) No 661/2009 Regulation (EU) No 1005/2010	A	
28A	Rear fog lamps for power-driven vehicles and their trailers	Regulation (EC) No 661/2009 UNECE Regulation No 38	X	X
29A	Reversing lights for power-driven vehicles and their trailers	Regulation (EC) No 661/2009 UNECE Regulation No 23	X	X
30A	Parking lamps for power-driven vehicles	Regulation (EC) No 661/2009 UNECE Regulation No 77	X	
31A	Safety-belts, restraint systems, child restraint systems and Isofix child restraint systems	Regulation (EC) No 661/2009 UNECE Regulation No 16	X	
33A	Location and identification of hand controls, tell-tales and indicators	Regulation (EC) No 661/2009 UNECE Regulation No 121	X	
34A	Windscreen defrosting and demisting systems	Regulation (EC) No 661/2009 Regulation (EU) No 672/2010	(⁵)	
35A	Windscreen wiper and washer systems	Regulation (EC) No 661/2009 Regulation (EU) No 1008/2010	(⁶)	
36A	Heating systems	Regulation (EC) No 661/2009 UNECE Regulation No 122	X	
41A	Emissions (Euro VI) heavy duty vehicles/access to information	Regulation (EC) No 595/2009	X (⁹)	
42A	Lateral protection of goods vehicles	Regulation (EC) No 661/2009 UNECE Regulation No 73	X	A
43A	Spray suppression systems	Regulation (EC) No 661/2009 Regulation (EU) No 109/2011	X	A

45	Safety glazing	Directive 92/22/EEC	X	
45A	Safety glazing materials and their installation on vehicles	Regulation (EC) No 661/2009 UNECE Regulation No 43	X	
46	Tyres	Directive 92/23/EEC	X	I
46A	Installation of tyres	Regulation (EC) No 661/2009 Regulation (EU) No 458/2011	X	I
46C	Pneumatic tyres for commercial vehicles and their trailers (Classes C2 and C3)	Regulation (EC) No 661/2009 UNECE Regulation No 54	X	I
46D	Tyre rolling sound emissions, adhesion on wet surfaces and rolling resistance (Classes C1, C2 and C3)	Regulation (EC) No 661/2009 UNECE Regulation No 117	X	I
47A	Speed limitation of vehicles	Regulation (EC) No 661/2009 UNECE Regulation No 89	X	
48A	Masses and dimensions	Regulation (EC) No 661/2009 Regulation (EU) No 1230/2012	A	A
49A	Commercial vehicles with regard to their external projections forward of the cab's rear panel	Regulation (EC) No 661/2009 UNECE Regulation No 61	A	
50A	Mechanical coupling components of combinations of vehicles	Regulation (EC) No 661/2009 UNECE Regulation No 55	X ⁽¹⁰⁾	X
50B	Close-coupling device (CCD); fitting of an approved type of CCD	Regulation (EC) No 661/2009 UNECE Regulation No 102	X ⁽¹⁰⁾	X ⁽¹⁰⁾
56A	Vehicles for the carriage of dangerous goods	Regulation (EC) No 661/2009 UNECE Regulation No 105	X ⁽¹³⁾	X ⁽¹³⁾

57A	Front underrun protective devices (FUPDs) and their installation; front underrun protection (FUP)	Regulation (EC) No 661/2009 UNECE Regulation No 93	A	
62	Hydrogen system	Regulation (EC) No 79/2009	X	
63	General Safety	Regulation (EC) No 661/2009	X ⁽¹⁵⁾	X ⁽¹⁵⁾
65	Advanced emergency braking system	Regulation (EC) No 661/2009 Regulation (EU) No 347/2012	N/A ⁽¹⁶⁾	
66	Lane departure warning system	Regulation (EC) No 661/2009 Regulation (EU) No 351/2012	N/A ⁽¹⁷⁾	
67	Specific components for liquefied petroleum gases (LPG) and their installation on motor vehicles	Regulation (EC) No 661/2009 UNECE Regulation No 67	X	
69	Electric safety	Regulation (EC) No 661/2009 UNECE Regulation No 100	X	
70	Specific components for CNG and their installation on motor vehicles	Regulation (EC) No 661/2009 UNECE Regulation No 110	X	

Explanatory Notes on the applicability of the requirements

X The requirements set out in the relevant regulatory act are applicable. The series of amendments of the UNECE regulations that apply on a compulsory basis are listed in Annex IV to Regulation (EC) No 661/2009. The series of amendments adopted subsequently are accepted as an alternative. Member States may grant extensions to existing type-approvals granted in accordance with the Directives repealed by Regulation (EC) 661/2009 under the conditions laid down in Article 13(14) of that Regulation.

N/A This regulatory act is not applicable to this vehicle (no requirements).

(1) For vehicles with a reference mass not exceeding 2 610 kg. At the manufacturer's request, Regulation (EC) No 715/2007 may apply to vehicles with a reference mass not exceeding 2 840 kg.

With regard to access to information, for other parts (e.g. living compartment) than the base vehicle, it is sufficient that the manufacturer provides access to vehicle repair and maintenance information in a readily accessible and prompt manner.

(2) In case of vehicles equipped with a LPG or CNG installation, a vehicle type-approval in accordance with UNECE Regulation No 67 or UNECE Regulation No 110 is required.

(3) The fitting of an electronic stability control ('ESC') system is required by Article 12 and Article 13 of Regulation (EC) No 661/2009. However, in accordance with UNECE Regulation No 13, the fitting of an ESC system is not required for special purpose vehicles of categories M₂, M₃, N₂ and N₃ and for vehicles for exceptional load transport and trailers with areas for standing passengers. N₁ vehicles may be approved in accordance with UNECE Regulations No 13 or No 13-H.

(4) The fitting of an ESC system is required by Article 12 and Article 13 of Regulation (EC) No 661/2009. Therefore, the requirements set out in Part A of Annex 9 to UNECE Regulation No 13-H shall be fulfilled. N₁ vehicles may be approved in accordance with UNECE Regulation No 13 or UNECE Regulation No 13-H.

- (4A) If fitted, the protective device shall fulfil the requirements set out in UNECE Regulation No 18.
- (4B) This Regulation applies to seats not falling within the scope of UNECE Regulation No 80. For other options, see Article 2 of Regulation (EC) No 595/2009.
- (5) Vehicles of categories other than M₁ do not need to fully comply with Regulation (EU) No 672/2010 but shall be fitted with a windscreen defrosting and demisting device.
- (6) Vehicles of categories other than M₁ do not need to fully comply with Regulation (EU) No 1008/2010 but shall be fitted with a windscreen washing and wiping devices.
- (8) For vehicles with a reference mass exceeding 2 610 kg and that did not benefit from the possibility offered in note (1).
- (9) For vehicles with a reference mass exceeding 2 610 kg that are not type-approved (at the manufacturer's request and provided their reference mass does not exceed 2 840 kg) under Regulation (EC) No 715/2007. For other parts than the base vehicle, it is sufficient that the manufacturer provides access to vehicle repair and maintenance information in a readily accessible and prompt manner
- (9A) Applies only where such vehicles are fitted with equipment covered by UNECE Regulation No 64. Tyre pressure monitoring system for M1 vehicles applies on a compulsory basis in accordance with Article 9(2) of Regulation (EC) No 661/2009.
- (10) Applies only to vehicles equipped with coupling(s).
- (11) Applies to vehicles with a technically permissible maximum laden mass not exceeding 2,5 tonnes.
- (12) Only applicable to vehicles where the 'Seating Reference Point ("R" point)' of the lowest seat is not more than 700 mm above the ground level.
- (13) Applies only where the manufacturer applies for type-approval of vehicles intended for the transport of dangerous goods.

- (¹⁴) Applies only for vehicles of category N₁, class I (reference mass ≤ 1 305 kg)
- (¹⁵) At the request of the manufacturer, a type-approval may be granted under this item, as an alternative to obtaining type-approvals under each individual item covered by Regulation (EC) No 661/2009.
- (¹⁶) The fitting of an advanced emergency braking system is not required for special purpose vehicles in accordance with Article 1 of Regulation (EU) No 347/2012.
- (¹⁷) The fitting of a lane departure warning system is not required for special purpose vehicles in accordance with Article 1 of Regulation (EU) No 351/2012.
- A The approval authority may only grant exemption(s) if the manufacturer demonstrates that the vehicle cannot meet the requirements due to its special purpose. The exemptions granted are to be described on the vehicle type-approval certificate and the certificate of conformity (remark –item 52 of the CoC).
- A₁ The fitting of ESC is not mandatory. In the case of multi-stage type-approvals, where the modifications made at a particular stage are likely to affect the function of the base vehicle's ESC system, the manufacturer may either disable the system or demonstrate that the vehicle has not been rendered unsafe or unstable. This may be demonstrated, e.g., by performing rapid double lane-change manoeuvres in each direction at 80 km/h with sufficient severity to cause intervention by the ESC system. These interventions are to be well-controlled and should improve the stability of the vehicle. The technical service has the right to request further testing if deemed necessary.
- B Application limited to doors giving access to the seats designated for normal use where the vehicle is used on a public road and where the distance between the R point of the seat and the average plane of the door surface, measured perpendicular to the longitudinal medium plane of the vehicle, does not exceed 500 mm.

- C Application limited to that part of the vehicle in front of the rearmost seat designated for normal use where the vehicle is used on a public road and also limited to the head impact zone as defined in the relevant regulatory act.
- D Application limited to seats designated for normal use where the vehicle is used on a public road. Seats that are not designated for use where the vehicle is used on the public road are to be clearly identified to users either by means of a pictogram or a sign with an appropriate text. The luggage retention requirements of UNECE Regulation No 17 do not apply.
- E Front only.
- F Modification to the routing and length of the refuelling duct and re-positioning of the tank inboard is permissible.
- G In case of multi-stage type-approval, requirements according to the category of the base/incomplete vehicle (e.g. the chassis of which was used to build the special purpose vehicle) may also be used.
- H Modification of exhaust system length after the last silencer not exceeding 2 m is permissible without any further test.
- I Tyres are to be type-approved in accordance with the requirements set out in UNECE Regulation No 54 even if the design speed of the vehicle is less than 80 km/h. The load capacity may be adjusted in relation to the maximum design speed of the trailer in agreement with the tyre manufacturer.
- J For all window glazing other than driver's cab glazing (windshield and side glasses), the material may be either of safety glass or rigid plastic glazing.
- K Additional panic alarm devices are permitted.

- L Application limited to seats designated for normal use where the vehicle is used on a public road. At least anchorages for lap belts are required in the rear seating positions. Seats that are not designated for use where the vehicle is used on a public road are to be clearly identified to users either by means of a pictogram or a sign with an appropriate text. ISOFIX is not required on ambulances and hearses.
- M Application limited to seats designated for normal use where the vehicle is used on a public road. At least lap belts are required in all rear seating positions. Seats that are not designated for use when the vehicle is used on a public road are to be clearly identified to users either by means of a pictogram or a sign with an appropriate text. ISOFIX is not required on ambulances and hearses.
- N Provided that all mandatory lighting devices are installed and that the geometric visibility is not affected.
- Q Modification of exhaust system length after the last silencer not exceeding 2 m is permissible without any further test. An EU type-approval issued to the most representative base vehicle remains valid irrespective of change in the reference weight.
- R Provided that the registration plates of all Member States can be mounted and remain visible.
- S The light transmission factor is at least 60 % and the “A” pillar obstruction angle is not more than 10 degrees.
- T Test to be performed only with the complete/completed vehicle. The vehicle can be tested in accordance with Directive 70/157/EEC. Concerning point 5.2.2.1 of Annex I to Directive 70/157/EEC, the following limit values are applicable:
- (a) 81 dB(A) for vehicles with an engine power of less than 75 kW;
 - (b) 83 dB(A) for vehicles with an engine power of not less than 75 kW but less than 150 kW;
 - (c) 84 dB(A) for vehicles with an engine power of not less than 150 kW.

- U Test to be performed only with the complete/completed vehicle. Vehicles up to 4 axles are to comply with all the requirements laid down in the relevant regulatory acts Derogations are admitted for vehicles having more than 4 axles, provided that
- (a) they are justified by the particular construction;
 - (b) all the braking performances, related to parking, service and secondary braking laid down in the relevant regulatory act are fulfilled.
- U₁ ABS is not mandatory for vehicles with hydrostatic drive.
- V Alternatively, Directive 97/68/EC may also apply.
- V₁ Alternatively, Directive 97/68/EC may also apply to vehicles with hydrostatic drive.
- W₀ Modification of exhaust system length is permitted without any further test, provided that the back pressure is similar. If a new test is required, an extra 2dB(A) above the applicable limit is allowed.
- W₁ Modification in the exhaust system is permitted without any further test of tailpipe emissions and CO₂/fuel consumption provided that the emission control devices, including particulate filters (if any), are not affected. If the evaporative control devices are kept as fitted by the manufacturer of the base vehicle, no new evaporative test is required on the modified vehicle. An EU type approval issued to the most representative base vehicle remains valid irrespective of change in the reference mass.
- W₂ Modification of the routing, length of the refuelling duct, fuel hoses and fuel vapour pipes is permitted without further test. Re-location of the original fuel tank is permitted provided all requirements are met. However, further testing in accordance with Annex 5 to UNECE Regulation No 34 are not required.

W₃ The longitudinal plane of the intended wheelchair-travelling position should be parallel to the longitudinal plane of the vehicle.

Appropriate information is to be made available to the vehicle owner that, in order to withstand the forces transmitted by the tie-down mechanism during the various driving conditions, a wheelchair with a structure meeting the relevant part of ISO 7176-19:2008 is recommended.

The seats of the vehicle may be adapted without further testing, provided it can be demonstrated to the technical service that their anchorages, mechanisms and head restraints provide the same level of performance.

The luggage retention requirements set out in UNECE Regulation No 17 do not apply.

W₄ Compliance with the relevant regulatory act(s) is required for the boarding aids when in the resting position.

W₅ Each wheelchair location is to be provided with anchorages to which a wheelchair tie-down and occupant restraint system (WTORS) is to be fitted, and that complies with the additional provisions for testing the wheelchair tie down and occupant restraint system set out in Appendix 3.

W₆ Each wheelchair location is to be provided with an occupant restraint belt that complies with the additional provisions for testing the wheelchair tie down and occupant restraint system of set out in Appendix 3.

When, due to the conversion, anchorage points for the safety belts need to be moved outside the tolerance provided for in paragraph 7.7.1 of UNECE Regulation No 16-06, the technical service is to check whether the alteration constitutes a worst case or not. If that is the case, the test provided for in paragraph 7.7.1. of UNECE Regulation No 16-06 is to be performed. Extension to the EU type-approval does not need to be issued. The test may be performed using components that have not undergone the conditioning test prescribed by UNECE Regulation No 16-06.

- W₈ For the purposes of calculations, the mass of the wheel-chair including the user is assumed to be 160 kg. The mass is to be concentrated at the P point of the surrogate wheelchair in its travelling position declared by the manufacturer.
- Any limitation in the passenger capacity resulting from the use of wheelchair(s) is to be recorded in the owner's handbook, on side 2 of the EU type-approval certificate and in the certificate of conformity (remark section).
- W₉ Modification of the exhaust system length is permitted without the need for retesting, provided that the exhaust back pressure remains similar.
- Y Provided that all mandatory lighting devices are installed.
- Z The requirements on the protrusion of open windows do not apply to the living compartment.
- Z₁ Mobile cranes with more than six axles are considered to be off-road vehicles (N3G) when at least three axles are driven and provided they meet the provisions of Annex II, point 4.3(b)(ii) and (iii), as well as point 4.3(c).

PROCEDURES TO BE FOLLOWED WITH RESPECT TO EU TYPE-APPROVAL

1. Objectives and scope

1.1. This Annex establishes the procedures for the proper operation of the vehicle type-approval in accordance with Articles 24, 25 and 26.

1.2. It also includes:

- (a) the list of international standards which are of relevance for the designation of the technical services in accordance with Articles 72 and 74;
- (b) the description of the procedure to be followed for the assessment of the skills of technical services in accordance with Article 77;
- (c) the general requirements for the drafting of test reports by technical services.

2. Type-approval procedure

When receiving an application for vehicle type-approval, the approval authority shall:

- (a) verify that all EU type-approval certificates issued pursuant to the regulatory acts which are applicable for vehicle type-approval cover the type of vehicle and correspond to the prescribed requirements;

- (b) make sure that the vehicle specifications and data contained in Part I of the vehicle information document are included in the data in the information packages and in the EU type-approval certificates issued in accordance with the relevant regulatory acts;
- (c) when an item number in Part I of the information document is not included in the information package as provided for in any of the regulatory acts, confirm that the relevant part or characteristic conforms to the particulars in the information folder;
- (d) on a selected sample of vehicles from the type to be approved carry out or arrange to be carried out inspections of vehicle parts and systems to verify that the vehicle or vehicles are built in accordance with the relevant data contained in the authenticated information package in respect of the relevant EU type-approval certificates;
- (e) carry out or arrange to be carried out relevant installation checks in respect of separate technical units, where applicable;
- (f) carry out or arrange to be carried out necessary checks in respect of the presence of the devices provided for in notes 1 and 2 of Part I of Annex IV, where applicable;
- (g) carry out or arrange to be carried out necessary checks in order to ensure that the requirements set out in note 5 of Part I of Annex IV are fulfilled.

3. Combination of technical specifications

The number of vehicles to be submitted shall be sufficient to permit the proper check of the various combinations to be type-approved according to the following criteria:

Technical specifications	Vehicle category										
	M ₁	M ₂	M ₃	N ₁	N ₂	N ₃	O ₁	O ₂	O ₃	O ₄	
Engine	X	X	X	X	X	X	—	—	—	—	
Gear box	X	X	X	X	X	X	—	—	—	—	
Number of axles	—	X	X	X	X	X	X	X	X	X	
Powered axles (number, position and interconnection)	X	X	X	X	X	X	—	—	—	—	
Steered axles (number and position)	X	X	X	X	X	X	X	X	X	X	
Body styles	X	X	X	X	X	X	X	X	X	X	
Number of doors	X	X	X	X	X	X	X	X	X	X	
Hand of drive	X	X	X	X	X	X	—	—	—	—	
Number of seats	X	X	X	X	X	X	—	—	—	—	
Level of equipment	X	X	X	X	X	X	—	—	—	—	

4. Specific provisions

Where no approval certificates as provided for in the relevant regulatory acts are available, the approval authority shall:

- (a) arrange for the necessary tests and checks as required by each of the relevant regulatory acts;
- (b) verify that the vehicle conforms to the particulars in the vehicle information folder and that it meets the technical requirements of each of the relevant regulatory acts;
- (c) carry out or arrange to be carried out relevant installation checks in respect of separate technical units, where applicable;
- (d) carry out or arrange to be carried out necessary checks in respect of the presence of the devices provided for in notes 1 and 2 of Part I of Annex IV where applicable;
- (e) carry out or arrange to be carried out necessary checks in order to ensure that the requirements set out in note 5 of Part I of Annex IV are fulfilled.

Appendix I

Standards with which the entities referred to in Article 72 have to comply

1. Activities related to testing for type-approval to be carried out in accordance with the regulatory acts listed in Annex IV:

1.1. Category A (tests performed in own facilities):

EN ISO/IEC 17025:2005 on the general requirements for the competence of testing and calibration laboratories.

A technical service designated for category A activities may also carry out the tests provided for in the regulatory acts for which it has been designated, in the facilities of a manufacturer or of a third party.

In each case, the personnel responsible for using professional judgement for determination of conformity with the regulatory acts for which the technical service has been designated shall comply with the relevant provisions of EN ISO/IEC 17020:2012.

1.2. Category B (supervising of tests performed in the manufacturer's facilities or in the facilities of a third party):

EN ISO/IEC 17020:2012 on the general criteria for the operation of various types of bodies performing inspection.

Before performing or supervising any test in the facilities of a manufacturer or of a third party, the technical service shall verify that the tests facilities and measurement devices comply with the appropriate requirements of EN ISO/IEC 17025:2005.

2. Activities related to Conformity of Production

2.1. Category C (procedure for the initial assessment and surveillance audits of the manufacturer's quality management system):

EN ISO/IEC 17021:2011 on the requirements for bodies providing audit and certification of management systems.

2.2. Category D (inspection or testing of production samples or supervision thereof):

EN ISO/IEC 17020:2012 on the general criteria for the operation of various types of bodies performing inspection.

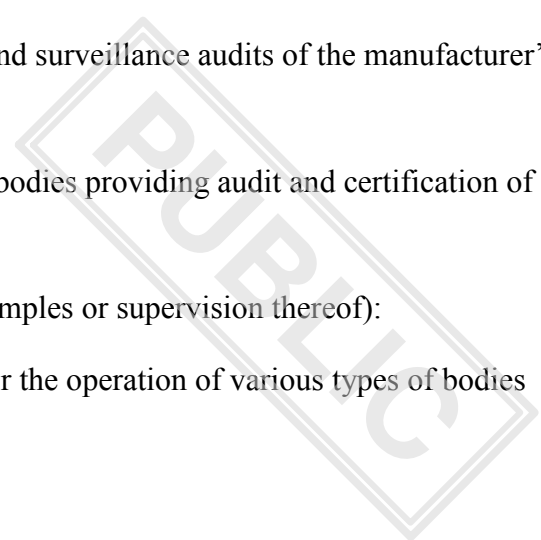

Appendix 2

Procedure for the assessment of the technical services

1. Objective and scope

- 1.1. This Appendix establishes the conditions according to which the assessment procedure of the technical services shall be conducted by the competent authority referred to in Article 77.
- 1.2. Those requirements shall apply to all technical services, irrespective of their legal status (independent organisation, manufacturer or approval authority acting as technical service).

2. Assessments

The carrying out of an assessment shall be governed by the following:

- (i) principle of independence, which is the basis for the impartiality and objectivity of the conclusions,
- (ii) an evidence-based approach, which guarantees reliable and reproducible conclusions.

Auditors shall show trust and integrity. They shall respect confidentiality and discretion.

They shall report truthfully and accurately findings and conclusions.

3. Skills required of the auditors

- 3.1. The assessments may only be conducted by auditors having the technical and administrative knowledge necessary for such purposes.
- 3.2. The auditors shall have been trained specifically for assessment activities. In addition, they shall have the specific knowledge of the technical area in which the technical service will exercise its activities.
- 3.3. Without prejudice to points 3.1 and 3.2, the assessment referred to in Article 77 shall be conducted by auditors independent of the activities for which the assessment is conducted.

4. Application for designation

4.1. A duly authorised representative of the applicant technical service shall make a formal application to the competent authority that includes the following information:

- (a) general features of the technical service, including corporate entity, name, addresses, legal status and technical resources;
- (b) a detailed description, including curriculum vitae, of the personnel in charge of testing and of the managerial staff as evidenced by the skills both educational and professional;
- (c) technical services which use virtual testing methods shall provide evidence of their ability to work in a Computer-Aided-x environment;
- (d) general information concerning the technical service, including its activities, its relationship in a larger corporate entity, if any, and addresses of all its physical location(s) to be covered by the scope of designation;
- (e) an agreement to fulfil the requirements for designation and the other obligations of the technical service as provided for in the relevant regulatory acts for which it is designated;
- (f) a description of the conformity assessment services that the technical service undertakes in the framework of the relevant regulatory acts and a list of the regulatory acts for which the technical service applies for designation, including limits of capability, where applicable;
- (g) a copy of the quality assurance manual of the technical service.

4.2. The competent authority shall review the adequacy of the information provided by the technical service.

4.3. The technical service shall notify to the approval authority any modifications to the information provided in accordance with point 4.1.

5. Resource review

The competent authority shall review its ability to carry out the assessment of the technical service, in terms of its own policy, its competence and the availability of suitable auditors and experts.

6. Subcontracting the assessment

6.1. The competent authority may subcontract parts of the assessment to another designation authority or ask for support from technical experts provided by other competent authorities. The subcontractors and experts have to be accepted by the applicant technical service.

6.2. The competent authority shall take into account accreditation certificates with adequate scope in order to complete its global assessment of the technical service.

7. Preparation for assessment

7.1. The competent authority shall formally appoint an assessment team. The competent authority shall ensure that the expertise brought to each assignment is appropriate. In particular, the team as a whole shall have both:

- (a) appropriate knowledge of the specific scope for which designation is sought;
- (b) sufficient understanding to reliably assess the competence of the technical service to operate within its scope of designation.

- 7.2. The competent authority shall clearly define the assignment given to the assessment team. The task of the assessment team is to review the documents collected from the applicant technical service and to conduct the on-site assessment.
- 7.3. The competent authority shall agree, together with the technical service and the assigned assessment team, to the date and timetable for the assessment. However, it remains the responsibility of the competent authority to pursue a date that is in accordance with the surveillance and reassessment plan.
- 7.4. The competent authority shall ensure that the assessment team is provided with the appropriate criteria documents, previous assessment records, and the relevant documents and records of the technical service.
8. On-site assessment

The assessment team shall conduct the assessment of the technical service at the premises of the technical service from which one or more key activities are performed and, where relevant, shall perform eyewitness assessment at other selected locations where the technical service operates.

9. Analysis of findings and assessment report

9.1. The assessment team shall analyse all relevant information and evidence gathered during the document and record review and the on-site assessment. This analysis shall be sufficient to allow the team to determine the extent of competence and conformity of the technical service with the requirements for designation.

9.2. The competent authority's reporting procedures shall ensure that the following requirements are fulfilled.

9.2.1. A meeting shall take place between the assessment team and the technical service prior to leaving the site. At this meeting, the assessment team shall provide a written and/or oral report on its findings obtained from the analysis. An opportunity shall be provided for the technical service to ask questions about the findings, including non-conformities, if any, and their basis.

9.2.2. A written report on the outcome of the assessment shall be promptly brought to the attention of the technical service. This assessment report shall contain comments on competence and conformity, and shall identify non-conformities, if any, to be resolved in order to conform to all of the requirements for designation.

9.2.3. The technical service shall be invited to respond to the assessment report and to describe the specific actions taken or planned to be taken, within a specific period of time, to resolve any identified non-conformities.

- 9.3. The competent authority shall ensure that the responses of the technical service are sufficient and effective to resolve non-conformities. If the technical service responses are found to be insufficient, further information shall be requested. Additionally, evidence of effective implementation of actions taken may be requested, or a follow-up assessment may be carried out, to verify effective implementation of corrective actions.
- 9.4. The assessment report shall include at least the following:
- (a) unique identification of the technical service;
 - (b) date(s) of the on-site assessment;
 - (c) name(s) of the auditors(s) and/or experts involved in the assessment;
 - (d) unique identification of all premises assessed;
 - (e) proposed scope of designation that was assessed;
 - (f) a statement on the adequacy of the internal organisation and procedures adopted by the technical service supporting its competence, as determined through its fulfilment of the requirements for designation;
 - (g) information on resolving all non-conformities;
 - (h) a recommendation of whether the applicant should be designated or confirmed as technical service and, if so, the scope of designation.

10. Granting or confirming a designation

- 10.1. The approval authority shall, without undue delay, make the decision on whether to grant, confirm or extend a designation on the basis of the assessment report(s) and any other relevant information.
- 10.2. The approval authority shall provide a certificate to the technical service. This certificate shall identify the following:
- (a) the identity and logo of the approval authority;
 - (b) the unique identity of the designated technical service;
 - (c) the effective date of granting of designation and the expiry date;
 - (d) a brief indication of or a reference to the scope of designation (relevant regulatory acts or part of them);
 - (e) a statement of conformity and a reference to this Regulation.

11. Reassessment and surveillance

11.1. Reassessment is similar to an initial assessment except that experience gained during previous assessments shall be taken into account. Surveillance on-site assessments are less comprehensive than reassessments.

11.2. The competent authority shall design its plan for reassessment and surveillance of each designated technical service so that representative samples of the scope of designation are assessed on a regular basis.

The interval between on-site assessments, whether reassessment or surveillance, depends on the proven stability that the technical service has reached.

11.3. Where, during surveillance or reassessments, non-conformities are identified, the competent authority shall define strict time limits for corrective actions to be implemented.

11.4. Where the corrective or improvement actions have not been taken within the agreed timeframe or are not deemed to be sufficient, the competent authority shall adopt appropriate measures, such as conducting a further assessment, or suspending or withdrawing the designation for one or more of the activities for which the technical service has been designated.

11.5. Where the competent authority decides to suspend or withdraw the designation of a technical service, it shall inform the technical service of its decision by registered mail. In any case, the competent authority shall adopt all the necessary measures to ensure the continuity of the activities already undertaken by the technical service.

12. Records on designated technical services

12.1. The competent authority shall maintain records on technical services to demonstrate that the requirements for designation, including competence, have been effectively fulfilled.

12.2. The competent authority shall keep the records on technical services secure to ensure confidentiality.

12.3. Records on technical services shall include at least the following:

- (a) relevant correspondence;
- (b) assessment records and reports;
- (c) copies of designation certificates.

Appendix 3

[...]

ANNEX VI

[...]

ANNEX VII

[...]

ANNEX VIII

[...]

ANNEX IX

[...]

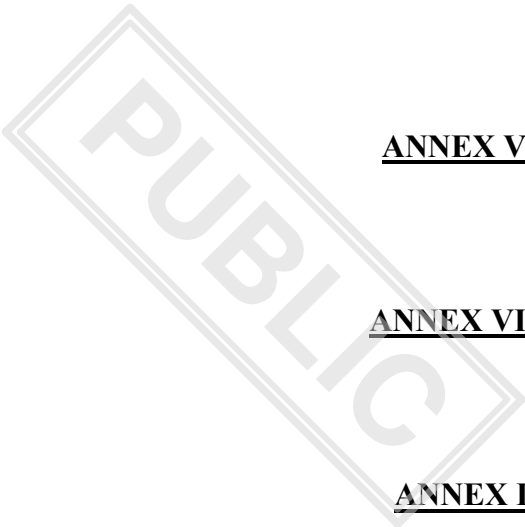

CONFORMITY OF PRODUCTION PROCEDURES

1. Objectives

- 1.1. The conformity of production procedure aims to ensure that each vehicle, system, component and technical separate unit, part or equipment produced is in conformity with the approved type.
- 1.2. The conformity of production procedure shall always include the assessment of quality-assurance management systems, referred to in point 2 as the ‘initial assessment’, and the verification of the type-approval subject and product-related controls, referred to in point 3 as ‘product conformity arrangements’.

2. Initial assessment

- 2.1. Before granting type-approval, the approval authority shall verify that the manufacturer has established satisfactory arrangements and procedures for ensuring that vehicles, systems, components, separate technical units or parts and equipment are produced in conformity with the approved type.
- 2.2. Guidance for conducting those assessments may be found in Standard EN ISO 19011:2011 — Guidelines for quality and/or environmental management systems auditing.
- 2.3. Compliance with the requirements of point 2.1 shall be verified to the satisfaction of the approval authority, as follows:

The approval authority shall be satisfied with the initial assessment and the product conformity arrangements referred to in point 3, taking into account one of the arrangements referred to in points 2.3.1 to 2.3.3, or a combination of those arrangements in full or in part as appropriate.

2.3.1. The initial assessment and verification of product conformity arrangements shall be carried out by the approval authority or a body appointed for this purpose by the approval authority.

2.3.1.1. When considering the extent of the initial assessment to be carried out, the approval authority may take into account the following information:

- (a) whether the manufacturer has a certification similar to the one referred to in point 2.3.3, but which has not been qualified or recognised under that point;
- (b) in the case of a type-approval of a system, component or separate technical unit, quality system assessments that have been performed by vehicle manufacturer(s) in the premises of the manufacturer of the system, component or separate technical unit, in accordance with one or more of the industry sector specifications satisfying the requirements in the EN ISO 9001:2015 or ISO/TS16949:2009 standards.
- (c) whether in one of the Member States one or more of the manufacturer's type approvals recently have been withdrawn, due to unsatisfactory control of conformity of production. In that case, the initial assessment by the approval authority shall not be limited to accepting the manufacturer's quality system certification, but shall include a verification whether all necessary improvements for ensuring effective control have been implemented, so that vehicles, components, systems or separate technical units are produced in conformity with the approved type.

2.3.2. The initial assessment and verification of product conformity arrangements may be carried out by the approval authority of another Member State or by the body appointed for this purpose by the approval authority.

2.3.2.1. The approval authority of that other Member State shall in that case prepare a statement of compliance, which outlines the areas and production facilities that that approval authority has covered as relevant to the product(s) to be type-approved and to the regulatory acts in accordance with which these products are to be type-approved.

2.3.2.2. On receiving a request for a statement of compliance from the approval authority of a Member State granting type-approval, the approval authority of another Member State shall immediately send that statement of compliance or inform that approval authority that is unable to provide such a statement.

2.3.2.3. The statement of compliance shall include at least the following:

- | | |
|------------------------------|---|
| (a) Group or company | (e.g. XYZ Automotive) |
| (b) Particular organisation | (e.g. regional Division) |
| (c) Plants/Sites | (e.g. Engine Plant 1 (in country A) — Vehicle Plant 2 (in country B)) |
| (d) Vehicle/Component range | (e.g. All Category M ₁ models) |
| (e) Areas assessed | (e.g. Engine assembly, body pressing and assembly, vehicle assembly) |
| (f) Documents examined | (e.g. Company and site quality manual and procedures) |
| (g) Date of the assessment | (e.g. Audit conducted from dd/mm/yyyy to dd/mm/yyyy) |
| (h) Planned monitoring visit | (e.g. mm/yyyy) |

2.3.3. An approval authority may also accept the manufacturer's certification to standards EN ISO 9001:2008 or ISO/TS16949:2009 (the scope of this certification shall in that case cover the product(s) to be approved), or an equivalent certification standard as satisfying the initial assessment requirements of point 2.3., provided that conformity of production is indeed covered by the quality management system and that the manufacturer's type-approval has not been withdrawn as referred to in point 2.3.1.1.(c). The manufacturer shall provide details of the certification and inform the approval authority of any revisions to its validity or scope.

- 2.4. For the purpose of vehicle type-approval, the initial assessments carried out for the granting of type-approvals for systems, components and separate technical units of the vehicle need not be repeated, but shall be completed by an assessment of the locations and activities relating to the assembly of the whole vehicle that have not been covered by the former assessments.
3. Product conformity arrangements
- 3.1. Every vehicle, system, component or separate technical unit, part or item of equipment approved pursuant to a UNECE Regulation annexed to the Revised 1958 Agreement and to this Regulation shall be so manufactured as to conform to the type approved by meeting the requirements of this Annex, the said UNECE Regulation and this Regulation.
- 3.2. Before granting a type-approval pursuant to this Regulation and to a UNECE Regulation annexed to the Revised 1958 Agreement, the approval authority shall verify the existence of adequate arrangements and documented control plans, to be agreed with the manufacturer for each approval, to carry out at specified intervals the tests or associated checks that are necessary to verify continued conformity with the approved type, including, where applicable, tests specified in this Regulation and the said UNECE Regulation.

3.3. The holder of the type-approval shall, in particular:

3.3.1. ensure the existence and application of procedures for effective control of the conformity of products (vehicles, systems, components, separate technical units, parts or equipment to the approved type;

3.3.2. have access to the testing or other appropriate equipment necessary for checking the conformity to each approved type;

3.3.3. ensure that the data resulting from tests or checks are recorded and that annexed documents remain available for a period of up to 10 years to be determined in agreement with the approval authority;

3.3.4. analyse the results of each type of test or check, in order to verify and ensure the stability of the product characteristics, making allowance for variation of an industrial production;

3.3.5. ensure that for each type of product, at least the checks prescribed in this Regulation and the tests prescribed in the relevant regulatory acts listed in Annex IV are carried out;

3.3.6. ensure that any set of samples or test pieces that gives evidence of non-conformity in the type of test in question, gives rise to a further sampling and testing. All the necessary steps shall be taken to restore the production process to ensure conformity with the approved type;

- 3.4. In the case of step-by-step, mixed or multi-stage type-approvals, the approval authority that is granting a whole-vehicle type-approval may request from any approval authority that has granted type-approval of any relevant system, component or separate technical unit specific details regarding compliance with the conformity of production requirements set out in this Annex.
- 3.5. The approval authority that is granting a whole-vehicle type-approval and is not satisfied with the reported information referred to in point 3.4., and that has communicated this in writing to the relevant manufacturer and to the approval authority granting the type-approval for the system, component or separate technical unit, shall demand the performance of additional conformity of production audits or checks, which shall be performed at the site of the manufacturer(s) of those systems, components or separate technical units. The results of this additional conformity of production audits or checks shall immediately be made available to that approval authority.
- 3.6. Where points 3.4. and 3.5. apply and the approval authority granting the whole-vehicle type-approval has not been satisfied with the additional audit or check results, the manufacturer shall ensure that conformity of production is restored as soon as possible to the satisfaction of that approval authority and of the approval authority granting type-approval of the system, component or separate technical unit.

4. Continued verification arrangements

4.1. The authority that has granted type-approval may at any time verify the conformity control methods applied in each production facility by means of periodic audits. The manufacturer shall for that purpose allow access to that authority to the manufacturing, inspection, testing, storage and distribution sites and shall provide all necessary information with regard to the quality management system documentation and records.

4.1.1. The normal arrangements for such periodic audits shall be to monitor the continued effectiveness of the procedures laid down in sections 1 and 2 (initial assessment and product conformity arrangements).

4.1.1.1. Surveillance activities carried out by the technical services (qualified or recognised as required in point 2.3.3) shall be accepted as satisfying the requirement of point 4.1.1 with regard to the procedures established at initial assessment.

4.1.1.2. The normal frequency of verifications by the approval authority (other than those referred to in point 4.1.1.1) shall be such as to ensure that the relevant controls applied in accordance with sections 1 and 2 are reviewed at intervals based on a risk assessment methodology that complies with the international standard ISO 31000:2009 – Risk Management – Principles and Guidelines and such verification shall in any case be conducted at least once every three years. This methodology shall in particular take into account any non-conformity raised by other Member States in the context of Article 54(1).

- 4.2. At every review, records of tests or checks and records of production, in particular records of those tests or checks documented as required in point 2.2., shall be made available to the inspector.
- 4.3. The inspector may select samples at random to be tested in the manufacturer's laboratory or in the facilities of the technical service. In such a case only physical test shall be carried out. The minimum number of samples may be determined on the basis of the results of the manufacturer's own verification.
- 4.4. The inspector who is of the opinion that the level of control is unsatisfactory, or who deems it necessary to verify the validity of the tests carried out in accordance with point 4.2, shall select samples to be sent to a technical service to perform physical tests in accordance with the requirements on conformity of production, set out in the regulatory acts referred to in Annex IV.
- 4.5. Where unsatisfactory results are found during an inspection or a monitoring review, the approval authority shall take all necessary steps to ensure that the manufacturer restores the conformity of production as rapidly as possible.
- 4.6. In cases where compliance with UNECE regulations is required by this Regulation, the manufacturer may choose to apply the provisions of this Annex as an equivalent alternative to the conformity of production requirements in the respective UNECE regulations. However, if points 4.4. or 4.5. apply, all separate conformity of production requirements in the UNECE regulations have to be complied with to the satisfaction of the approval authority until it decides that conformity of production has been restored.

[...]



SMALL SERIES AND END-OF-SERIES LIMITS**A. SMALL SERIES LIMITS**

1. The number of units of one type of vehicle to be registered, sold or put into service annually in the Union shall not exceed, pursuant to Article 39, the figures shown in the following table for the vehicle category in question:

Category	Units
M ₁	1 500
M ₂ , M ₃	0
N ₁	1500
N ₂ , N ₃	0 until the date of application of the delegated acts adopted in accordance with Article 39(4). 1500 after that date
O ₁ , O ₂	0
O ₃ , O ₄	0

2. The number of units of one type of vehicle to be registered, sold or put into service annually in a Member State, shall be determined by that Member State but shall not exceed, pursuant to Article 40, the figures shown in the following table for the vehicle category in question:

Category	Units
M ₁	250
M ₂ , M ₃	250
N ₁	250
N ₂ , N ₃	250
O ₁ , O ₂	500
O ₃ , O ₄	250

3. [...]

B. END-OF-SERIES LIMITS

The maximum number of complete and completed vehicles put into service in each Member State under the procedure “End-of-Series” shall be restricted in one of the following ways to be chosen by the Member State:

1. The maximum number of vehicles of one or more types may, in the case of category M1 not exceed 10 % and in the case of all other categories not exceed 30 % of the vehicles of all types concerned put into service in that Member State during the previous year.
Should 10 %, respectively 30 %, be less than 100 vehicles, then the Member State may allow the putting into service of a maximum of 100 vehicles.
2. Vehicles of any one type shall be restricted to those for which a valid certificate of conformity was issued on or after the date of manufacture and which remained valid for at least three months after its date of issue but subsequently lost its validity due to the entry into force of a regulatory act.

ANNEX XIII

LIST OF PARTS OR EQUIPMENT THAT ARE CAPABLE OF POSING A SIGNIFICANT RISK TO THE CORRECT FUNCTIONING OF SYSTEMS THAT ARE ESSENTIAL FOR THE SAFETY OF THE VEHICLE OR ITS ENVIRONMENTAL PERFORMANCE, THE PERFORMANCE REQUIREMENTS OF SUCH PARTS AND EQUIPMENT, THE APPROPRIATE TEST PROCEDURES, AND MARKING AND PACKAGING PROVISIONS

I. Parts or equipment having a significant impact on vehicle safety

Item No	Item description	Performance requirement	Test procedure	Marking requirement	Packaging requirements
1	[...]				
2					
3					

II. Parts or equipment having a significant impact on the environmental performance of the vehicle

Item No	Item description	Performance requirement	Test procedure	Marking requirement	Packaging requirements
1	[...]				
2					
3					

[...]



REGULATORY ACTS FOR WHICH A MANUFACTURER MAY BE DESIGNATED AS A
TECHNICAL SERVICE

1. Objectives and scope

- 1.1. This Annex lays down the list of the regulatory acts for which a manufacturer may be designated as a technical service in accordance with Article 76(1).
- 1.2. It also includes appropriate provisions concerning the designation of a manufacturer as technical service, to be applied in the framework of the type-approval of vehicles, components and separate technical units concerned by Part I of Annex IV.
- 1.3. This Annex however does not apply to manufacturers who apply for the EU type-approval of vehicles produced in small series, as referred to in Article 39.

2. Designation of a manufacturer as a technical service

- 2.1. A manufacturer designated as a technical service is a manufacturer who has been designated by the approval authority as a testing laboratory to carry out on its behalf the approval tests.

The expression ‘to carry out tests’ is not restricted to the measurement of performances, but also covers the registration of test results and the submission to the approval authority of a report, including the relevant conclusions.

It also covers the checking of compliance with those provisions that do not necessarily require measurement. This is the case for the assessment whether the design complies with the legislative requirements.

3. List of regulatory acts and restrictions

	Subject	Regulatory act reference
4A	Space for mounting and fixing rear registration plates	Regulation (EC) No 661/2009 Regulation (EU) No 1003/2010
7A	Audible warning devices and signals	Regulation (EC) No 661/2009 UNECE Regulation No 28
10A	Electromagnetic compatibility	Regulation (EC) No 661/2009 UNECE Regulation No 10
18A	Manufacturer's statutory plate and vehicle identification number	Regulation (EC) No 661/2009 Regulation (EU) No 19/2011
20A	Installation of lighting and light-signalling devices on vehicles	Regulation (EC) No 661/2009 UNECE Regulation No 48
27A	Towing device	Regulation (EC) No 661/2009 Regulation (EU) No 1005/2010 ³⁷
33A	Location and identification of hand controls, tell-tales and indicators	Regulation (EC) No 661/2009 UNECE Regulation No 121

³⁷ Commission Regulation (EU) No 1005/2010 of 8 November 2010 concerning type-approval requirements for motor vehicle towing devices and implementing Regulation (EC) No 661/2009 of the European Parliament and of the Council concerning type-approval requirements for the general safety of motor vehicles, their trailers and systems, components and separate technical units intended therefor (OJ L 291, 9.11.2010, p. 36).

34A	Windscreen defrosting and demisting systems	Regulation (EC) No 661/2009 Regulation (EU) No 672/2010
35A	Windscreen wiper and washer systems	Regulation (EC) No 661/2009 Regulation (EU) No 1008/2010
36A	Heating systems	Regulation (EC) No 661/2009 UNECE Regulation No 122 Except the provisions in Annex 8 relating to LPG combustion heaters and LPG heating systems
37A	Wheel guards	Regulation (EC) No 661/2009 Regulation (EU) No 1009/2010
44A	Masses and dimensions	Regulation (EC) No 661/2009 Regulation (EU) No 1230/2012
45A	Safety glazing materials and their installation on vehicles	Regulation (EC) No 661/2009 UNECE Regulation No 43 Restricted to the provisions included in Annex 21
46	Tyres	Directive 92/23/EEC

46A	Installation of tyres	Regulation (EC) No 661/2009 Regulation (EU) No 458/2011
48A	Masses and dimensions	Regulation (EC) No 661/2009 Regulation (EU) No 1230/2012
49A	Commercial vehicles with regard to their external projections forward of the cab's rear panel	Regulation (EC) No 661/2009 UNECE Regulation No 61
50A	Mechanical coupling components of combinations of vehicles	Regulation (EC) No 661/2009 UNECE Regulation No 55 Restricted to the provisions included in Annex 5 (up to and including paragraph 8) and Annex 7
61	Air-conditioning system	Directive 2006/40/EC

Appendix

Designation of a manufacturer as technical service and subcontracting

1. General

1.1. The designation and notification of a manufacturer as a technical service shall be made in accordance with Articles 72 to 86 and any subcontracting shall be done in accordance with the provisions of this Appendix.

2. Subcontracting

2.1. In accordance with Article 75(1), a technical service may nominate a subcontractor for performing tests on his behalf.

2.2. For the purposes of this Appendix, the following definition shall apply:

– 'Subcontractor' means either a subsidiary of the technical service that has been entrusted by that technical service with testing activities inside its own organisation or a third party under contract with that technical service to perform test activities.

2.3. The use of the services of a subcontractor does not liberate the technical service from its obligation to comply with Articles 73, 74, 84 and 85, and in particular with those concerning the skills of the technical services and compliance with Standard EN ISO/IEC 17025:2005.

2.4. Section 2 of Annex XV shall apply to the subcontractor.

3. Test report

Test reports shall be drafted in accordance with the general requirements set out in Appendix 3 of Annex V to Regulation (EU) No XXX/201X.

**CONDITIONS FOR THE USE OF VIRTUAL TESTING METHODS BY A MANUFACTURER
OR A TECHNICAL SERVICE**

1. Objectives and scope

This Annex lays down provisions concerning virtual testing in accordance with Article 28(4).

2. List of regulatory acts

	Subject	Regulatory act reference
3B	Rear underrun protective devices (RUPDs) and their installation; rear underrun protection (RUP)	Regulation (EC) No 661/2009 UNECE Regulation No 58
6A	Vehicle access and manoeuvrability	Regulation (EC) No 661/2009 Regulation (EU) No 130/2012
6B	Door latches and door retention components	Regulation (EC) No 661/2009 UNECE Regulation No 11
8A	Devices for indirect vision and their installation	Regulation (EC) No 661/2009 UNECE Regulation No 46

12A	Interior fittings	Regulation (EC) No 661/2009 UNECE Regulation No 21
16A	External projections	Regulation (EC) No 661/2009 UNECE Regulation No 26
20A	Installation of lighting and light-signalling devices on vehicles	Regulation (EC) No 661/2009 UNECE Regulation No 48
27A	Towing device	Regulation (EC) No 661/2009 Regulation (EU) No 1005/2010
32A	Forward field of vision	Regulation (EC) No 661/2009 UNECE Regulation No 125
35A	Windscreen wiper and washer systems	Regulation (EC) No 661/2009 Regulation (EU) No 1008/2010
37A	Wheel guards	Regulation (EC) No 661/2009 Regulation (EU) No 1009/2010
42A	Lateral protection of goods vehicles	Regulation (EC) No 661/2009 UNECE Regulation No 73

48A	Masses and dimensions	Regulation (EC) No 661/2009 Regulation (EU) No 1230/2012
49A	Commercial vehicles with regard to their external projections forward of the cab's rear panel	Regulation (EC) No 661/2009 UNECE Regulation No 61
50A	Mechanical coupling components of combinations of vehicles	Regulation (EC) No 661/2009 UNECE Regulation No 55
50B	Close-coupling device (CCD); fitting of an approved type of CCD	Regulation (EC) No 661/2009 UNECE Regulation No 102
52A	M2 and M3 vehicles	Regulation (EC) No 661/2009 UNECE Regulation No 107
52B	Strength of the superstructure of large passenger vehicles	Regulation (EC) No 661/2009 UNECE Regulation No 66
57A	Front underrun protective devices (FUPDs) and their installation; front underrun protection (FUP)	Regulation (EC) No 661/2009 UNECE Regulation No 93

Appendix I

General conditions for the use of virtual testing methods

1. Virtual test pattern

The following scheme shall be used as basis structure for describing and conducting virtual testing:

- (a) purpose;
- (b) structure model;
- (c) boundary conditions;
- (d) load assumptions;
- (e) calculation;
- (f) assessment;
- (g) documentation.

2. Fundamentals of computer simulation and calculation

2.1. Mathematical model

The mathematical model shall be supplied by the manufacturer. It shall reflect the complexity of the structure of the vehicle, system, component or separate technical unit to be tested in relation to the requirements of the relevant regulatory act and its boundary conditions.

The same provisions shall apply for testing components or separate technical units independently from the vehicle.

2.2. Validation process of the mathematical model

The mathematical model shall be validated against the actual test conditions.

To that effect a physical test shall be conducted to compare the results obtained when using the mathematical model with the results of a physical test. Comparability of the test results shall be proven. The manufacturer or the technical service shall draft a validation report and submit it to the approval authority.

Any change to the mathematical model or to the software that is likely to invalidate the validation report shall be brought to the attention of the approval authority, which may require that a new validation process is conducted.

The flow chart of the validation process is shown in Appendix 3.

2.3. Documentation

The manufacturer shall make available to the technical service and document the data and auxiliary tools used for simulation and calculation.

3. Tools and support

The manufacturer shall supply the technical service at its request with the necessary tools to conduct the virtual testing, including appropriate software, or provide that technical service access to these tools.

The manufacturer shall also provide appropriate support to the technical service.

The access and support provided by the manufacturer to a technical service does not exempt the technical service from its obligations regarding the skills of its personnel, the payment of licence rights and confidentiality.

Appendix 2

Specific conditions for the use of virtual testing methods

1. List of regulatory acts

	Regulatory act reference	Annex and paragraphs	Specific conditions
3B	Regulation (EC) No 661/2009 UNECE Regulation No 58	Paragraphs 2.3, 7.3. and 25.6 of UNECE Regulation No 58.	Dimensions and resistance to forces.
6A	Regulation (EC) No 661/2009 Regulation (EU) No 130/2012	Annex II, Part I and 2 of Regulation (EU) No 130/2012.	Dimensions of steps, running boards and handholds.
6B	Regulation (EC) No 661/2009 UNECE Regulation No 11	Annex 3 of UNECE Regulation No 11. Annex 4, paragraph 2.1. of UNECE Regulation No 11. Annex 5 of UNECE Regulation No 11.	Tensile strength tests and resistance of latches to acceleration.
8A	Regulation (EC) No 661/2009 UNECE Regulation No 46	Paragraph 15.2.4. of UNECE Regulation No 46.	Prescribed fields of vision of rear- view mirrors.

12A	Regulation (EC) No 661/2009 UNECE Regulation No 21	(a) Paragraphs 5. to 5.7. of UNECE Regulation No 21. (b) Paragraph 2.3. of UNECE Regulation No 21.	(a) Measurement of all radii of curvature and of all projections except for those requirements where a force has to be applied in order to check compliance with the provisions. (b) Determination of the head- impact zone.
16A	Regulation (EC) No 661/2009 UNECE Regulation No 26	Paragraph 5.2.4. of UNECE Regulation No 26 All provisions in paragraphs 5 (General requirements) and 6 (Particular requirements) of UNECE Regulation No 26.	Measurement of all radii of curvature and of all projections except for those requirements where a force has to be applied in order to check compliance with the provisions.
20A.	Regulation (EC) No 661/2009 UNECE Regulation No 48	Paragraph 6. (Individual specifications), and Annexes 4, 5 and 6 to UNECE Regulation No 48.	The test drive provided for in paragraph 6.22.9.2.2 shall be performed on a real vehicle.
27A	Regulation (EC) No 661/2009 Regulation (EU) No 1005/2010	Annex II, point 1.2. of Regulation (EU) No 1005/2010.	Tractive and compressive static force.

32A	Regulation (EC) No 661/2009 UNECE Regulation No 125	Paragraph 5 (Specifications) of UNECE Regulation No 125.	Obstructions and field of vision.
35A	Regulation (EC) No 661/2009 Regulation (EU) No 1008/2010	Annex III, points 1.1.2. and 1.1.3. of Regulation (EU) No 1008/2010.	Determination of the swept area only.
37A	Regulation (EC) No 661/2009 Regulation (EU) No 1009/2010	Annex II, point 2. of Regulation (EU) No 1009/2010.	Verification of the dimensional requirements.
42A	Regulation (EC) No 661/2009 UNECE Regulation No 73	Paragraph 12.10 of UNECE Regulation No 73.	Resistance under a horizontal force and deflection measurement.
48A.	Regulation (EC) No 661/2009 Regulation (EU) No 1230/2012	(a) Annex I, Part B, points 7 and 8 of Regulation (EU) No 1230/2012. (b) Annex I, Part C, points 6 and 7 of Regulation (EU) No 1230/2012.	(a) Check of compliance with the manoeuvrability requirements including manoeuvrability of vehicles fitted with lift- or loadable axles. (b) Measurement of the maximum rear swing-out.

49A	Regulation (EC) No 661/2009 UNECE Regulation No 61	Paragraphs 5 and 6 of UNECE Regulation No 61.	Measurement of all radii of curvature and of all projections except for those requirements where a force has to be applied in order to check compliance with the provisions.
50A	Regulation (EC) No 661/2009 UNECE Regulation No 55	(a) Annex 5 'Requirements for mechanical coupling devices' of UNECE Regulation No 55. (b) Annex 6, paragraph 1.1. of UNECE Regulation No 55. (c) Annex 6, paragraph 3 of UNECE Regulation No 55.	(a) All provisions of paragraphs 1 to 8 included. (b) Strength tests on mechanical couplings of simple design may be replaced by virtual tests. (c) Paragraphs 3.6.1. (Strength test), 3.6.2. (Resistance to buckling) and 3.6.3. (Resistance to bending moment) only.
52A	Regulation (EC) No 661/2009 UNECE Regulation No 107	Annex 3 of UNECE Regulation No 107.	Paragraph 7.4.5. (calculation method).
52B	Regulation (EC) No 661/2009 UNECE Regulation No 66	Annex 9 of UNECE Regulation No 66.	Computer simulation of rollover test on complete vehicle as an equivalent approval method.
57A	Regulation (EC) No 661/2009 UNECE Regulation No 93	Annex 5, paragraph 3 of UNECE Regulation No 93.	Resistance under a horizontal force and deflection measurement.

Validation process

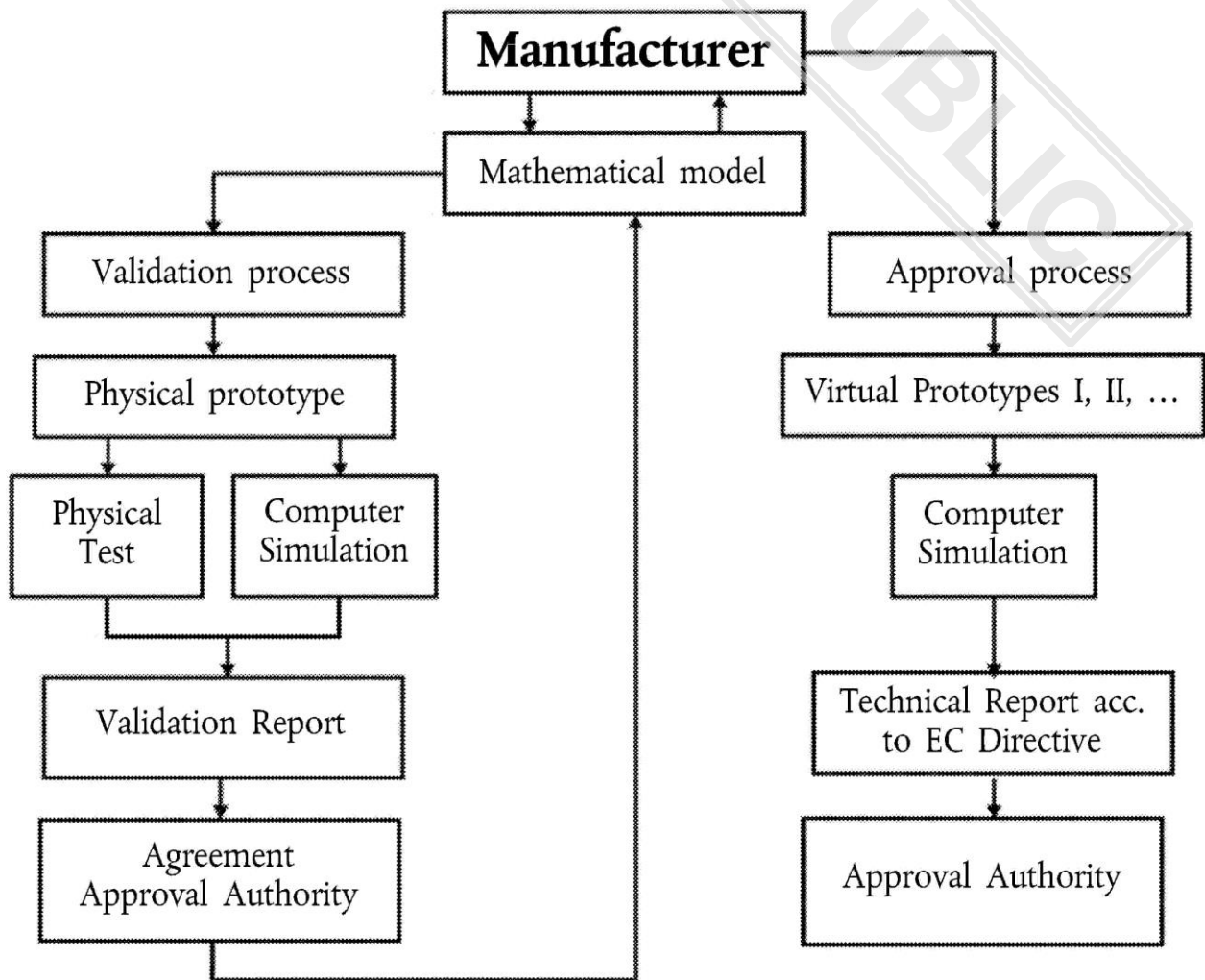

**PROCEDURES TO BE FOLLOWED
DURING EU MULTI-STAGE TYPE-APPROVAL**

1. Obligations of manufacturers
 - 1.1. The satisfactory operation of the EU multi-stage type-approval requires joint action by all the manufacturers concerned. To this end approval authorities must ensure, before granting first and subsequent stage approvals, that suitable arrangements exist between the relevant manufacturers for the supply and interchange of documents and information, so that the completed type of vehicle meets the technical requirements of all the relevant regulatory acts referred to in Annex IV. Such information must include details of relevant system, component and separate technical unit type-approvals and of vehicle parts that form part of the incomplete vehicle but have not yet been approved.
 - 1.2. Each manufacturer involved in a EU multi-stage type-approval shall be responsible for the approval and conformity of production of all systems, components or separate technical units manufactured by him or added by him to the previously built stage. The manufacturer of the subsequent stage shall not be responsible for objects that have been approved in an earlier stage, except where he modifies relevant parts to such an extent that the previously granted approval becomes invalid.

2. Obligations of approval authorities
- 2.1. The approval authority shall:
- (a) verify that all EU type-approval certificates issued pursuant to the regulatory acts that are applicable for vehicle type-approval cover the type of vehicle at its state of completion and correspond to the prescribed requirements;
 - (b) ensure that all the relevant data, taking account of the state of completion of the vehicle, is included in the information folder;
 - (c) by reference to the documentation ensure that the vehicle specification(s) and data contained in Part I of the vehicle information folder are included in the data in the information packages and in the EU type-approval certificates issued in accordance with the relevant regulatory acts; and in the case of a completed vehicle, where an item number in Part I of the information folder is not included in the information package of any of the regulatory acts, confirm that the relevant part or characteristic conforms to the particulars in the information folder;
 - (d) on a selected sample of vehicles from the type to be approved carry out or arrange to be carried out inspections of vehicle parts and systems to verify that the vehicle(s) is/are built in accordance with the relevant data contained in the authenticated information package in accordance with all relevant regulatory acts;
 - (e) where required carry out, or arrange to be carried out, relevant installation checks for separate technical units.

2.2. The number of vehicles to be inspected for the purposes of paragraph 2.1 (d) shall be sufficient to permit the proper control of the various combinations to be EU type-approved according to the state of completion of the vehicle and the following criteria:

- engine,
- gearbox,
- powered axles (number, position, interconnection),
- steered axles (number and position),
- body styles,
- number of doors,
- hand of drive,
- number of seats,
- level of equipment

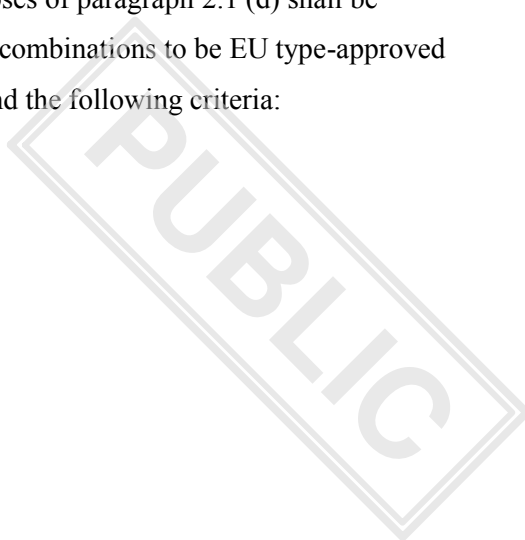

3. Applicable requirements
- 3.1. EU multi-stage type-approvals shall be granted on the basis of the state of completion of the type of vehicle and shall incorporate all approvals granted at earlier stages.
- 3.2. For the whole-vehicle type-approval, this Regulation (in particular the requirements of Annex II and the particular acts listed in Annex IV) shall apply in the same manner as if the approval would have been granted (or extended) to the manufacturer of the base vehicle.
- 3.2.1 Where a type of system, component or separate technical unit has not been modified, the system, component or separate technical unit type-approval granted in the previous stage shall remain valid until the expiration date for the first registration, as specified in the particular regulatory act.
- 3.2.2. Where a type of system has been modified at the subsequent stage of completion of the vehicle, to the extent that the system has to be retested for type-approval purposes, that retesting shall be limited to only those parts of the system that have been modified or affected by the changes.
- 3.2.3 Where a type of vehicle or a type of system has been modified by another manufacturer at the subsequent stage of completion of the vehicle, to the extent that, apart from the manufacturer's name, the vehicle or system may still be considered as the same type, the requirement applying to existing types may still be applied as long as the date for first registration in the relevant regulatory act has not been reached.

- 3.2.4. The change of category of a vehicle shall lead to the application of the relevant requirements to the new category of vehicle. The type-approval certificates from the previous category shall be accepted provided that the vehicle complies with the same requirements as, or more stringent than, those applying to the new category.
- 3.3. Subject to the agreement of the approval authority, a whole-vehicle type-approval granted to the manufacturer of the subsequent stage of completion of the vehicle does not need to be extended or revised where an extension given at the previous stage vehicle does not affect the subsequent stage or the technical data of the vehicle. However, the type-approval number including the extension of the previous stage(s) vehicle shall be copied in point 1.2.2 of the certificate of conformity of the subsequent stage vehicle.
- 3.4. Where the cargo area of a complete or completed vehicle of category N or O is modified by another manufacturer for the addition of removable fittings to store and secure the cargo (for example, load space lining, storage racks and roof racks), such items can be treated as part of the pay-mass and an approval is not needed, provided both of the following conditions are met:
- (a) the modifications do not affect the vehicle's type-approval in any way, other than an increase of the actual mass of the vehicle;
 - (b) the added fittings can be removed without using special tools.

4. Identification of the vehicle

4.1. The VIN, prescribed by Regulation (EU) No 19/2011, shall be retained during all the subsequent stages of the type-approval to ensure the “traceability” of the process.

4.2. At the second and subsequent stages, in addition to the statutory plate prescribed by Regulation (EU) No 19/2011, each manufacturer shall affix to the vehicle an additional plate the model of which is shown in the appendix to this Annex. This plate shall be firmly attached, in a conspicuous and readily accessible position on a part not subject to replacement in use. It shall clearly and indelibly show the following information in the order listed:

- the name of the manufacturer,
- sections 1, 3 and 4 of the EU type-approval number,
- the stage of approval,
- the VIN of the base vehicle,
- the technically permissible maximum laden mass of the vehicle where the value has changed during the current stage of approval,
- the technically permissible maximum laden mass of the combination (where the value has changed during the current stage of approval and where the vehicle is permitted to tow a trailer). “0” shall be used if the vehicle is not permitted to tow a trailer.
- the technically permissible maximum mass on each axle, listed in order from front to rear where the value has changed during the current stage of approval,
- in the case of a semi-trailer or centre axle trailer, the technically permissible maximum mass at the coupling point where the value has changed during the current stage of approval.

Unless otherwise provided for in points 4.1 and 4.2 the plate shall comply with the requirements set out in Annex I and Annex II to Regulation (EU) No 19/2011.

Appendix

MODEL OF THE MANUFACTURER'S ADDITIONAL PLATE

The example below is given as a guide only.

MANUFACTURER'S NAME (stage 3)
e2*201X/XX*2609
Stage 3
WD9VD58D98D234560
1 500 kg
2 500 kg
1 – 700 kg
2 – 810 kg

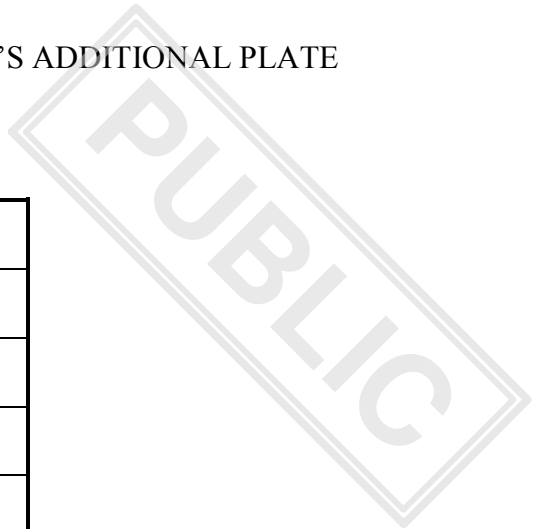

**ACCESS TO VEHICLE OBD AND VEHICLE REPAIR AND MAINTENANCE
INFORMATION**

1. Introduction

This Annex lays down technical requirements for the accessibility of vehicle OBD and vehicle repair and maintenance information.

2. Access to vehicle OBD and vehicle repair and maintenance information

- 2.1. A manufacturer shall put in place the necessary arrangements and procedures, in accordance with Article 65, to ensure that vehicle OBD and vehicle repair and maintenance information is accessible through websites using a standardised format in a readily accessible and prompt manner, and in a manner which is non-discriminatory compared to the provisions given or access granted to authorised dealers and repairers.
- 2.2. An approval authority shall only grant type-approval after receiving from the manufacturer a Certificate on Access to Vehicle OBD and Vehicle Repair and Maintenance Information.
- 2.3. The Certificate on Access to Vehicle OBD and Vehicle Repair and Maintenance Information shall serve as the proof of compliance with Article 68.
- 2.4. The Certificate on Access to Vehicle OBD and Vehicle Repair and Maintenance Information shall be drawn up in accordance with the model set out in Appendix 1 to this Annex.

2.5. The vehicle OBD and vehicle repair and maintenance information shall include the following:

2.5.1. an unequivocal identification of the vehicle, system, component or separate technical unit for which the manufacturer is responsible;

2.5.2. service handbooks, including service and maintenance records;

2.5.3. technical manuals;

2.5.4. component and diagnosis information (such as minimum and maximum theoretical values for measurements);

2.5.5. wiring diagrams;

2.5.6. diagnostic trouble codes, including manufacturer specific codes;

2.5.7. the software calibration identification number applicable to a type of vehicle;

2.5.8. information provided concerning, and delivered by means of, proprietary tools and equipment;

2.5.9. data record information and two-directional monitoring and test data;

2.5.10. standard work units or time periods for repair and maintenance tasks if they are made available to authorised dealers and repairers of the manufacturer either directly or through a third party;

2.5.11. in case of multi-stage type-approval, the information required under section 3, and all other information necessary to comply with the requirements set out in Article 65.

2.6. The manufacturer shall make available to interested parties the following information:

2.6.1. relevant information to enable the development of replacement components that are critical to the correct functioning of the OBD system;

2.6.2. information to enable the development of generic diagnostic tools.

2.7. For the purposes of point 2.6.1., the development of replacement components shall not be restricted by any of the following:

2.7.1. the unavailability of pertinent information;

2.7.2. the technical requirements relating to malfunction indication strategies if the OBD thresholds are exceeded or if the OBD system is unable to fulfil the basic OBD monitoring requirements of this Regulation;

2.7.3. specific modifications to the handling of OBD information to deal independently with vehicle operation on petrol or on gas;

2.7.4. the type-approval of gas-fuelled vehicles that contain a limited number of minor deficiencies.

2.8. For the purposes of point 2.6.2., where manufacturers use diagnostic and test tools in accordance with ISO 22900 – Modular vehicle communication interface (MVCI) – and ISO 22901 – Open diagnostic data exchange (ODX) in their franchised networks –, the ODX files shall be accessible to independent operators via the website of the manufacturer.

2.8a For the purpose of vehicle OBD, diagnostics, repair and maintenance, the direct vehicle data stream shall be made available through the serial port on the standardised data link connector specified in paragraph 6.5.1.4 of Appendix 1 of Annex 11 to UNECE Regulation No 83 and Section 4.7.3 of Annex 9B to UNECE Regulation No 49.

When the vehicle is in motion, the data shall be made available only for read-only functions.

3. Multi-stage type-approval

3.1. In the case of a multi-stage type-approval, the final manufacturer shall be responsible for providing access to vehicle OBD and vehicle repair and maintenance information regarding its own manufacturing stage(s) and the link to the previous stage(s).

3.2. In addition, the final manufacturer shall on its website provide independent operators with the following information:

3.2.1. the website address of the manufacturer(s) responsible for the previous stage(s);

3.2.2. the name and address of all the manufacturers responsible for the previous stage(s);

3.2.3. the type-approval number(s) of the previous stage(s);

3.2.4. the engine number.

- 3.3. Each manufacturer responsible for a particular stage or stages of type-approval shall be responsible for providing through his website access to vehicle OBD and vehicle repair and maintenance information regarding the stage(s) of type-approval for which he is responsible and the link to the previous stage(s).
- 3.4. The manufacturer responsible for a particular stage or stages of type-approval shall provide the following information to the manufacturer responsible for the next stage:
- 3.4.1. the certificate of conformity relating to the stage(s) for which he is responsible;
 - 3.4.2. the Certificate on Access to Vehicle OBD and Vehicle Repair and Maintenance Information, including its appendices;
 - 3.4.3. the type-approval number corresponding to the stage(s) for which he is responsible;
 - 3.4.4. the documents referred to in points 3.4.1., 3.4.2. and 3.4.3. as provided by the manufacturer(s) involved in the previous stage(s).

- 3.5 Each manufacturer shall authorise the manufacturer responsible for the next stage to pass the documents to the manufacturers responsible for any subsequent stages and the final stage.
- 3.6. In addition, on a contractual basis, the manufacturer responsible for a particular stage or stages of type-approval shall:
- 3.6.1. provide the manufacturer responsible for the next stage with access to vehicle OBD and vehicle repair and maintenance information and interface information corresponding to the particular stage(s) for which he is responsible;
- 3.6.2. provide, at the request of a manufacturer responsible for a subsequent stage of type-approval, with access to vehicle OBD and vehicle repair and maintenance information and interface information corresponding to the particular stage(s) for which he is responsible.
- 3.7. A manufacturer, including a final manufacturer, may only charge fees in accordance with Article 67 concerning the particular stage(s) for which he is responsible.

A manufacturer, including a final manufacturer, shall not charge fees for providing information relating to the website address or contact details of any other manufacturer.

4. Customer adaptations

- 4.1. By derogation from section 2, if the number of systems, components or separate technical units subject to a specific customer adaptation is lower than 250 units produced worldwide, repair and maintenance information for the customer adaptation shall be provided in a readily accessible and prompt manner, and in a manner which is non-discriminatory compared to the provisions given or access granted to authorised dealers and repairers.

For the servicing and reprogramming of the electronic control units relating to the customer adaptation, the manufacturer shall make the respective proprietary specialist diagnostic tool or test equipment available to independent operators as provided to authorised repairers.

The customer adaptations shall be listed on the manufacturer's repair and maintenance information website and mentioned in the Certificate on Access to Vehicle OBD and Vehicle Repair and Maintenance Information at the time of type-approval.

- 4.2. Manufacturers shall make the proprietary specialist diagnostic tool or test equipment to service the customer-adapted systems, components or technical units available to independent operators via sale and rent.
- 4.3. The manufacturer shall mention in the Certificate on Access to Vehicle OBD and Vehicle Repair and Maintenance Information, at the time of type-approval, the customer adaptations for which the obligation under section 2 to provide access to vehicle OBD and vehicle repair and maintenance information in a standardised format is derogated from and any electronic control unit related to them.

Those customer adaptations and any electronic control unit related to them shall also be listed on the manufacturer's repair and maintenance information website.

5. Small volume manufacturers

- 5.1. By derogation from section 2, manufacturers whose worldwide annual production of a type of vehicle, system, component or separate technical unit subject to this Regulation is for vehicles of category M1 and N1 less than 1000 vehicles or for vehicles of category M2, M3, N2, N3 and O less than 250 units, shall provide access to repair and maintenance information in a readily accessible and prompt manner, and in a manner that is non-discriminatory compared to the provisions given or access granted to authorised dealers and repairers.
- 5.2. The vehicle, system, component and separate technical unit subject to point 5.1. shall be listed on the manufacturer's repair and maintenance information website.
- 5.3. The approval authority shall inform the Commission of each type-approval granted to small volume manufacturers.

6. Requirements

- 6.1. Vehicle OBD and vehicle repair and maintenance information available through websites shall follow the common standard referred to in Article 65.

Those requiring the right to duplicate or republish the information shall negotiate directly with the manufacturer concerned. Information for training material shall also be available, but may be presented through other media than websites.

Information on all parts of the vehicle, with which the vehicle, as identified by the VIN and any additional criteria such as wheelbase, engine output, trim level or options, is equipped by the vehicle manufacturer and that can be replaced by spare parts offered by the vehicle manufacturer to its authorised repairers or dealers or third parties by means of reference to original equipment (OE) parts number, shall be made available, in the form of machine readable and electronically processable datasets, in a database that is easily accessible to independent operators.

This database shall comprise the VIN, OE parts numbers, OE naming of the parts, validity attributes (valid-from and valid-to dates), fitting attributes and, where applicable, structuring characteristics.

The information on the database shall be updated regularly. If this information is available to authorised dealers, the updates shall include in particular all modifications to individual vehicles after their production.

- 6.2. Access to vehicle security features used by authorised dealers and repair shops shall be made available to independent operators under protection of security technology in accordance with the following requirements:
- 6.2.1. data shall be exchanged ensuring confidentiality, integrity and protection against replay;
 - 6.2.2. the standard https//ssl-tls (RFC4346) shall be used;
 - 6.2.3. security certificates in accordance with ISO 20828 shall be used for mutual authentication of independent operators and manufacturers;
 - 6.2.4. the independent operator's private key shall be protected by secure hardware.
- 6.3. The Forum on Access to Vehicle Information referred to in Article 70 shall specify the parameters for fulfilling these requirements in accordance with the state of the art. The independent operator shall be approved and authorised for this purpose on the basis of documents demonstrating that he pursues a legitimate business activity and has not been convicted of any relevant criminal activity.
- 6.4. Reprogramming of control units shall be conducted in accordance with either ISO 22900-2 or SAE J2534 or TMC RP1210B using non-proprietary hardware.

For the validation of the compatibility of the manufacturer-specific application and the vehicle communication interfaces (VCI) complying to ISO 22900-2 or SAE J2534 or TMC RP1210B, the manufacturer shall offer either a validation of independently developed VCIs or the information, and loan of any special hardware, required for a VCI manufacturer to conduct such validation himself.

The conditions of Article 67(1) shall apply to fees for such validation or information and hardware.

- 6.5. The requirements of point 6.4. shall not apply in the case of reprogramming of speed limitation devices and recording equipment.
- 6.6. All emission-related DTCs shall be consistent with Annex XI to Commission Regulation (EC) No 692/2008³⁸ and Annex X to Commission Regulation (EU) No 582/2011/EC³⁹.
- 6.7. For access to any vehicle OBD and vehicle repair and maintenance information other than that relating to secure areas of the vehicle, registration requirements for use of the manufacturer's website by an independent operator shall require only such information as is necessary to confirm how payment for the information is to be made. For information concerning access to secure areas of the vehicle, the independent operator shall present a certificate in accordance with ISO 20828 to identify himself and the organisation to which he belongs and the manufacturer shall respond with his own certificate in accordance with ISO 20828 to confirm to the independent operator that he is accessing a legitimate site of the intended manufacturer. Both parties shall keep a log of any such transactions indicating the vehicles and changes made to them under this provision.

³⁸ Commission Regulation (EC) No 692/2008 of 18 July 2008 implementing and amending Regulation (EC) No 715/2007 of the European Parliament and of the Council on type-approval of motor vehicles with respect to emissions from light passenger and commercial vehicles (Euro 5 and Euro 6) and on access to vehicle repair and maintenance information (OJ L 199, 28.7.2008, p. 1).

³⁹ Commission Regulation (EU) No 582/2011 of 25 May 2011 implementing and amending Regulation (EC) No 595/2009 of the European Parliament and of the Council with respect to emissions from heavy duty vehicles (Euro VI) and amending Annexes I and III to Directive 2007/46/EC of the European Parliament and of the Council (OJ L 167, 25.6.2011, p. 1).

- 6.8. Manufacturers shall indicate in their repair information websites the type-approval number by model.
- 6.8.a In the event that vehicle OBD and vehicle repair and maintenance information available on a manufacturer's website does not contain specific relevant information to permit the proper design and manufacture of alternative fuels retrofit systems, any interested alternative fuels retrofit system manufacturer shall be able to obtain the information required in sections 1, 3, and 4 of the information document set out in Annex I by contacting the manufacturer directly with such a request. Contact details for that purpose shall be clearly indicated on the manufacturer's website and the information shall be provided within 30 days. Such information need only be provided for alternative fuels retrofit systems that are subject to UNECE Regulation No 115 or for alternative fuels retrofit components that form part of systems subject to UNECE Regulation No 115, and need only be provided in response to a request that clearly specifies the exact specification of the vehicle model for which the information is required and that specifically confirms that the information is required for the development of alternative fuels retrofit systems or components subject to UNECE Regulation No 115.

7. Requirements for type-approval

- 7.1. In order to receive a type-approval, the manufacturer shall submit the filled in certificate, the template of which is provided in Appendix I.
- 7.2. Where the vehicle OBD and vehicle repair and maintenance information is not available, or does not conform to the requirements of this Annex, the manufacturer shall provide that information within six months of the date of the type-approval.
- 7.3. The obligation to provide information within the dates referred to in point 7.2. shall apply only if, following the type-approval, the vehicle is placed on the market.

Where the vehicle is placed on the market more than six months after the type-approval has been granted the information shall be provided on the date on which the vehicle is placed on the market.

- 7.4. On the basis of a completed Certificate on Access to Vehicle OBD and Vehicle Repair and Maintenance Information, the approval authority may presume that the manufacturer has put in place satisfactory arrangements and procedures with regard to access to vehicle OBD and vehicle repair and maintenance information, provided that no complaint has been made and that the manufacturer provides that certificate within the periods referred to in point 7.2.

Appendix I

Manufacturer's certificate on access to vehicle OBD and
vehicle repair and maintenance information

(Manufacturer): ...

(Address of the manufacturer): ...

Certifies that

it provides access to vehicle OBD and vehicle repair and maintenance information in compliance with the provisions of:

Article 65 of Regulation (EU) No [.....] and Annex XVIII to that Regulation

with respect to the types of vehicle, system, component or separate technical unit listed in attachment to this Certificate.

The following derogations are applied: Customer adaptations ⁽¹³⁾ — Small volume ⁽¹³⁾ —.

The principal website address through which the relevant information may be accessed and which is hereby certified to be in compliance with those provisions are listed in an attachment to this Certificate along with the contact details of the responsible manufacturer's representative who has signed this Certificate.

Where applicable: The manufacturer hereby also certifies that he has complied with the obligation of Article 66 of Regulation (EU) No .../201.. to provide the relevant information concerning previous approvals of these types of vehicle no later than six months after the date of type-approval.

Done at ...[Place]

On ...[Date]

[Signature] [Position]

Annexes:

— Annex A: Website addresses,

— Annex B: Contact details.



ANNEX A

Website addresses referred to in this Certificate:

ANNEX B

Contact details of the manufacturer's representative referred to in this Certificate:



Appendix 2

Vehicle OBD information

1. The vehicle manufacturer shall provide the information required in this appendix for the purposes of enabling the manufacture of OBD-compatible replacement or service parts and diagnostic tools and test equipment.
2. Upon request, the following information shall be made available, on a non-discriminatory basis, to any interested manufacturer of components, diagnostic tools or test equipment:
 - 2.1. a description of the type and number of the preconditioning cycles used for the original type-approval of the vehicle;
 - 2.2. a description of the type of the OBD demonstration cycle used for the original type-approval of the vehicle for the component monitored by the OBD system;
 - 2.3. a comprehensive document describing all sensed components with the strategy for fault detection and MI activation (fixed number of driving cycles or statistical method), including a list of relevant secondary sensed parameters for each component monitored by the OBD system and a list of all OBD output codes and format used (with an explanation of each code and format) associated with individual emission-related power-train components and individual non-emission related components, where monitoring of the component is used to determine MI activation. In particular, in the case of types of vehicles that use a communication link in accordance with ISO 15765-4 'Road vehicles — Diagnostics on controller area network (CAN) — Part 4: Requirements for emissions-related systems', a comprehensive explanation for the data given in service \$ 05 Test ID \$ 21 to FF and the data given in service \$ 06, and a comprehensive explanation for the data given in service \$ 06 Test ID \$ 00 to FF, for each OBD monitor ID supported, shall be provided.

In case other communication protocols standards are used, equivalent comprehensive explanation shall be provided.

This information may be provided in the form of a table, with the following column and row headings:

Component Fault code; Monitoring strategy; Fault detection criteria; MI activation criteria; Secondary parameters; Preconditioning Demonstration test.

Catalyst P0420 Oxygen sensor; 1 and 2 signals; Difference between sensor 1 and sensor 2 signals; 3rd cycle Engine speed; engine load; A/F mode; catalyst temperature; Two Type 1 cycles Type 1.

3. Information required for the manufacturing of diagnostic tools

In order to facilitate the provision of generic diagnostic tools for multi-make repairers, vehicle manufacturers shall make available the information referred to in points 3.1, 3.2 and 3.3 through their repair information websites. That information shall include all diagnostic tool functions and all the links to repair information and troubleshooting instructions. The access to the information may be subject to the payment of a reasonable fee.

3.1. *Communication protocol information*

The following information shall be required indexed against vehicle make, model and variant, or another workable definition such as the VIN or the vehicle and systems identification:

- 3.1.1. any additional protocol information system necessary to enable complete diagnostics in addition to the standards prescribed in paragraph 4.7.3 of Annex 9B to UNECE Regulation No 49 and in paragraph 6.5.1.4 of Annex 11 to UNECE Regulation No 83, including any additional hardware or software protocol information, parameter identification, transfer functions, 'keep alive' requirements, or error conditions;
- 3.1.2. details of how to obtain and interpret all the fault codes that do not comply with the standards prescribed in paragraph 4.7.3 of Annex 9B to UNECE Regulation No 49 and in paragraph 6.5.1.4 of Annex 11 to UNECE Regulation No 83;
- 3.1.3. a list of all available live data parameters, including scaling and access information;
- 3.1.4. a list of all available functional tests, including device activation or control and the means to implement them;
- 3.1.5. details of how to obtain all component and status information, time stamps, pending DTC and freeze frames;
- 3.1.6. resetting adaptive learning parameters, variant coding and replacement component setup, and customer preferences;
- 3.1.7. Electronic control unit (ECU) identification and variant coding;
- 3.1.8. details of how to reset service lights;
- 3.1.9. location of diagnostic connector and connector details;
- 3.1.10. engine code identification.

3.2. *Test and diagnosis of OBD monitored components*

The following information shall be required:

- 3.2.1. a description of tests to confirm the functionality, at the component or in the harness;
- 3.2.2. information concerning the test procedure, including test parameters and component information;
- 3.2.3. connection details, including minimum and maximum input and output and driving and loading values;
- 3.2.4. values to be expected under certain driving conditions, including idling;
- 3.2.5. electrical values for the component in its static and dynamic states;
- 3.2.6. failure mode values for each of the scenarios;
- 3.2.7. failure mode diagnostic sequences, including fault trees and guided diagnostics elimination.

3.3. *Data required to perform the repair*

The following information shall be required:

- 3.3.1. ECU and component initialisation (in the event of replacements being fitted);
- 3.3.2. initialisation of new or replacement ECU's where relevant using pass-through (re-) programming techniques.

CORRELATION TABLE

1. Regulation (EC) No 715/2007

Regulation (EC) No 715/2007	This Regulation
Article 1(2)	Article 94(1)(1)
Article 3, points (14) and (15)	Article 3, points (48) and (49)
Article 6	Article 65
Article 7	Article 67
Article 8	-
Article 9	-
Article 13(2)(e)	Article 92(2)(e)

2. Regulation (EC) No 595/2009

Regulation (EC) No 595/2009	This Regulation
Article 1, second paragraph	Article 95(1)(1)
Article 3, points (11) and (13)	Article 3, points (48) and (49)
Article 6	Article 65
Article 11(2), point (e)	Article 92(2)(e)

5. Directive 2007/46/EC

Directive 2007/46/EC	This Regulation
Article 1	Article 1(1)
-	Article 1(2)
-	Article 1(3)
Article 2	Article 2
Article 3	Article 3
Article 3, point (1)	-
Article 3, point (2)	-
Article 3, point (3)	Article 3, point (1)
Article 3, point (4)	Article 3, point (27)

Article 3, point (5)	Article 3, point (23)
Article 3, point (6)	Article 3, point (43)
Article 3, point (7)	Article 3, point (21)
Article 3, point (8)	Article 3, point (31)
Article 3, point (9)	Article 3, point (32)
Article 3, point (10)	Article 3, point (33)
Article 3, point (11)	Article 3, point (11)
Article 3, point (12)	Article 3, point (12)
Article 3, point (13)	Article 3, point (3)
Article 3, point (14)	-
Article 3, point (15)	-
Article 3, point (16)	Article 3, point (10)
Article 3, point (17)	Article 3, point (36)
Article 3, point (18)	Article 3, point (38)
Article 3, point (19)	Article 3, point (22)
Article 3, point (20)	Article 3, point (34)
Article 3, point (21)	Article 3, point (35)
Article 3, point (22)	Article 3, point (44)
Article 3, point (23)	Article 3, point (4)
Article 3, point (24)	Article 3, point (5)
Article 3, point (25)	Article 3, point (6)
Article 3, point (26)	Article 3, point (46)
Article 3, point (27)	Article 3, point (9)
Article 3, point (28)	Article 3, point (25)

Article 3, point (29)	Article 3, point (13)
Article 3, point (30)	-
Article 3, point (31)	Article 3, point (37)
Article 3, point (32)	Article 3, point (42)
Article 3, point (33)	Article 3, point (24)
Article 3, point (34)	-
Article 3, point (35)	-
Article 3, point (36)	Article 3, point (28)
Article 3, points (37) to (40)	-
-	Article 3, point (2)
	Article 3, point (7)
	Article 3, point (8)
	Article 3, points (14) to 3(20)
	Article 3, point (26)
	Article 3, points (29) to 3(30)
	Article 3, points (39) to 3(41)
	Article 3, point (45)
	Article 3, points (47) to 3(56)
-	Article 4
	Article 5
Article 4	Article 6
	Article 7
Article 4(1)	Article 7(1)
Article 4(2)	Article 7(2)

Article 4(3), first subparagraph	Article 6(2)
Article 4(3), second subparagraph	Article 6(3)
Article 4(4)	Article 6(1)
-	Article 6(4)
-	Article 8
-	Article 9
-	Article 10
Article 5	Article 11
-	Article 11(1)
-	Article 11(3)
-	Article 11(5)
Article 5(1)	Article 11(6)
Article 5(2)	Article 11(2)
Article 5(3)	Article 11(4)
-	Article 11(7) to (8)
-	Article 12
-	Article 13
-	Article 14
-	Article 15
-	Article 16
-	Article 17
-	Article 18
-	Article 19
Article 6	Article 20



Article 6(1)	Article 20(1)
Article 6(2)	Article 20(2) and Article 23(1)
Article 6(3)	Article 20(3) and Article 23(2)
Article 6(4)	Article 20(4) and Article 23(3)
Article 6(5)	Article 20(5) and (6), and Article 23(4)
Article 6(6) and 7(1)	Article 21
Article 6(7) and (8)	Article 23(5) and Article 27(2)
Article 7 (2)	Article 22
Article 7(3) and (4)	Article 23(5) and Article 27(2)
-	Article 23
Article 8(1) and (2)	Article 24(1) and (2)
Article 8(3)	Article 24(3)
Article 8(4)	Article 24(4)
	Article 25
Article 8(5) and (6)	Article 25(1) and (2)
Article 8(7) and (8)	Article 25(3) and (4)
	Article 26
Article 9(1)	Article 24(2)
Article 9(2)	Article 24(2)
Article 9(3)	Article 26(3)
Article 9(4)	Article 26(4)
Article 9(5)	-
Article 9(6) and (7)	Article 26(5) and (6)
Article 10(1)	Article 27(1)

Article 10(2)	Article 27(1)
Article 10(3)	Article 27(2)
Article 10(4)	Article 27(3)
Article 11	Article 28
Article 12(1)	Article 29(1)
-	Article 29(2)
Article 12(2), first subparagraph,	Article 29(3)
Article 12(2), second subparagraph	Article 29(4)
Article 12(3)	Article 29(5)
	Article 30
Article 13(1)	Article 31(1)
Article 13(2)	Article 31(2)
Article 13(3)	Article 31(3)
Article 14(1)	Article 32(1)
Article 14(2)	Article 32(2)
Articles 14(3)	Article 32(3)
Article 14(4)	Article 32(4)
Article 15(1)	Article 32(1)
Article 15(2)	Article 32(2)
Article 15(3)	Article 32(3)
Article 16(1)	Article 25(1)
Article 16(2)	Article 25(1)
Article 16(3)	Article 25(2)
-	Article 31(1)

Article 17(1) to (3)	Article 33(2) to (4)
Article 17(4)	Article 33(5)
Article 18(1)	Article 34(1)
-	Article 34(2)
Article 18(2)	Article 34(3)
Article 18(3)	-
-	Article 34(4)
Article 18(4)	Article 34(5)
-	Article 35(1)
Article 18(5)	Article 35(2)
Article 18(6)	Article 35(3)
Article 18(7)	Article 34(6)
Article 18(8)	Article 34(1) third subparagraph
-	Article 36(1)
Article 19(1) and (2)	Article 36(2)
Article 19(3)	Article 36(3)
Article 20(1)	Article 37(1)
Article 20 (2) first subparagraph	Article 37(4)
Article 20 (2) (a) to (c)	Article 37(2)
Article 20(3)	Article 37(5)
Article 20(4), first subparagraph	Article 37(3)
Article 20(4), second subparagraph	Article 37(6)
Article 20(4), third subparagraph	Article 37(7)
Article 20 (5)	-

Article 21(1)	Article 38(1)
Article 21(2)	Article 38(2)
Article 22	Article 39
Article 23(1)	Article 40(1) and (2)
Article 23(2)	-
Article 23(3)	Article 40(2) third subparagraph
Article 23(4)	Article 40(3)
Article 23(5)	Article 40(4)
Article 23(6), first subparagraph	Article 41(1) and (2)
Article 23(6), second subparagraph	Article 41(3)
Article 23(6), third subparagraph	Article 41(4)
Article 23(7)	Article 41(5)
	Article 42
Article 24	Article 43 Article 44
Article 25	Article 45
Article 26(1)	Article 46(1)
Article 26(2)	Article 46(2)
Article 26(3)	Article 46(3)
Article 27(1)	Article 47(1)
Article 27(2)	Article 47(2)
Article 27(3)	Article 47(3)
Article 27(4)	-
-	Article 47(4)

-	Article 47(5)
Article 27 (5)	Article 47(6)
Article 28	Article 48
Article 29(1), first subparagraph	Article 49(1), first subparagraph
-	Article 49(1), second and third subparagraph
-	Article 49(2) to (4)
Article 29(1), second subparagraph	Article 50(1)
-	Article 50(2) to (5)
Article 29(2)	Article 52(4)
-	Article 51(1) and (2)
Article 29(3)	Article 51(3)
Article 29(4)	-
-	Article 52 (1) to (3)
-	Article 52(5)
Article 30(1)	Article 53(1)
Article 30(2), first subparagraph	Article 53(2)
Article 30(2), second subparagraph	-
Article 30(3)	Article 54(1)
Article 30(4)	Article 54(2) to (4), first subparagraph
Article 30(5)	Article 54(4), second subparagraph
Article 30(6)	Article 54(5)
Article 31(1) to (4)	Article 55
Article 31(5), first subparagraph	Article 56(1)

Article 31(5), second and third subparagraph	Article 56(2)
Article 31(6) and (7)	-
Article 31(8)	Article 56(3)
Article 31(9)	Article 56(4)
Article 31(10)	Article 56(6)
Article 31(11)	-
Article 31(12), first subparagraph	Article 56(7)
Article 31(12), second subparagraph	-
Article 31(13)	-
Article 32(1)	Article 57(1)
-	Article 57(2)
Article 32(2)	Article 57(3)
Article 32(3)	Article 58(1)
-	Article 58(2)
Article 33	Article 59
Article 34(1)	Article 60(1)
-	Article 60(2)
Article 34(2)	Article 60(3)
Article 34(3) and (4)	-
Article 35	Article 61
Article 36	Article 62
Article 37	Article 63

Article 38	Article 64
See correlation tables in points 1 to 4	Article 65
	Article 66
	Article 67
	Article 68
	Article 69
	Article 70
-	Article 71
Article 39	-
Article 40	Article 87
Article 41	Article 74
Article 41(2)	Article 84(1)
Article 41(3)	Article 72(1)
Article 41(4)	Article 74(2)
Article 41(5)	Article 72(2)
Article 41(6)	Article 76(1)
-	Article 76(2) and (3)
Article 41(7)	-
Article 41(8)	Article 76(4)
-	Article 73
-	Article 75
Article 42	Article 77
Article 43(1)	Article 78(1)
Article 43(2) to (3)	Article 78(2) to (3)
-	Article 78(4)

Article 43(4) to (5)	Article 78(5) to (6)
-	Article 79
-	Article 80
-	Article 81
-	Article 82
-	Article 83
-	Article 84
-	Article 85
-	Article 86
-	Article 87
-	Article 88
-	Article 89
Article 44	Article 96
Article 45	-
Article 46	Article 91
Article 47	-
Article 48	-
Article 49	Article 95
	Article 92
	Article 93
	Article 94
Article 51	-



Annex I	Annex I
Annex II	Annex II
Annex III	Annex III
Annex IV	Annex IV
Annex V	Annex V
Annex VI	Annex VI
Annex VII	Annex VII
Annex VIII	Annex VIII
Annex IX	Annex IX
Annex X	Annex X
Annex XI	-
-	Annex XI
Annex XII	Annex XII
Annex XIII	Annex XIII
Annex XIV	Annex XIV
Annex XV	Annex XV
Annex XVI	Annex XVI
Annex XVII	Annex XVII
-	Annex XVIII
Annex XVIII	-
Annex XIX	-
Annex XX	-
Annex XXI	Annex XIX

