



Council of the  
European Union

Brussels, 13 December 2021  
(OR. en)

14983/21

MAR 229  
OMI 104  
ENV 990  
CLIMA 445

**COVER NOTE**

---

From: Secretary-General of the European Commission, signed by Ms Martine DEPREZ, Director

date of receipt: 13 December 2021

To: Mr Jeppe TRANHOLM-MIKKELSEN, Secretary-General of the Council of the European Union

---

No. Cion doc.: SWD(2021) 400 final

---

Subject: COMMISSION STAFF WORKING DOCUMENT Union submission to the to the ninth session of the International Maritime Organization's Sub-Committee for Pollution Prevention and Response suggesting to update three guidelines linked to the International Convention on the Control of Harmful Anti-fouling Systems in Ships

---

Delegations will find attached document SWD(2021) 400 final.

---

Encl.: SWD(2021) 400 final



Brussels, 13.12.2021  
SWD(2021) 400 final

**COMMISSION STAFF WORKING DOCUMENT**

**Union submission to the to the ninth session of the International Maritime Organization's Sub-Committee for Pollution Prevention and Response suggesting to update three guidelines linked to the International Convention on the Control of Harmful Anti-fouling Systems in Ships**

## **Union submission to the ninth session of the International Maritime Organization's Sub-Committee for Pollution Prevention and Response suggesting to update three guidelines linked to the International Convention on the Control of Harmful Anti-fouling Systems in Ships**

### **PURPOSE**

This Staff Working Document contains a draft Union submission to the International Maritime Organization's (IMO) ninth Sub-Committee for Pollution Prevention and Response (PPR 9). The IMO has indicatively scheduled PPR 9 in hybrid format from 4 to 8 April 2022.

[Please make a reference to the 218 (9) decision establishing the Union position for the adoption by MEPC in June 2021 of the amendments to Annex I of the AFS Convention.]

The draft submission suggests to modify the three guidelines associated with the International Convention on the Control of Harmful Anti-fouling Systems in Ships (AFS Convention)<sup>1</sup>. It follows up on proposals from the EU and the IMO's recent adoption of amendments to the AFS Convention to ban the anti-fouling agent cybutryne at MEPC 76. The EU supported the amendments, with a position established by Council Decision (EU) 2021/778<sup>2</sup>. This is linked to the introduction of controls on the anti-foulant cybutryne and concerns the following texts:

- *Guidelines for brief sampling of anti-fouling systems on ships* (resolution MEPC.104(49));
- *Guidelines for survey and certification of anti-fouling systems on ships, 2010* (resolution MEPC.195(61)); and
- *Guidelines for inspection of anti-fouling systems on ships, 2011* (resolution MEPC.208(62)).

The draft submission contains three annexes that contain the suggested changes to each of the three Guidelines. This would bring the texts up to date with the changes status of cybutryne.

### **EU COMPETENCE**

Regulation (EU) No 528/2012<sup>3</sup> establishes a harmonised system in the EU concerning the placing on the market and use of biocidal active substances and biocidal products. In particular, it aims at establishing at Union level a list of active substances which may be used in biocidal products. Pursuant to Article 9 of Regulation (EU) No 528/2012, decisions to approve or not an active substance are adopted at EU level by the Commission.

Commission Implementing Decision (EU) 2016/107<sup>4</sup> did not approve cybutryne as an active substance for use in biocidal products for product-type 21—use in antifouling paints. The adoption of a non-approval decision triggered legal periods for market withdrawal and the end of use of biocidal products containing this substance.

Pursuant to Article 89(2) of Regulation 528/2012, Member States could have allowed the making

---

<sup>1</sup> International Convention on the Control of Harmful Anti-fouling Systems in Ships, International Maritime Organization, 2001

<sup>2</sup> Council Decision (EU) 2021/778 of 6 May 2021 on the position to be taken on behalf of the European Union during the 103<sup>rd</sup> session of the Maritime Safety Committee of the International Maritime Organization and the 76<sup>th</sup> session of the Marine Environment Protection Committee of the International Maritime Organization, on the adoption of amendments to the International Convention on Standards of Training, Certification and Watchkeeping for Seafarers, the International Code on the Enhanced Programme of Inspections during Surveys of Bulk Carriers and Oil Tankers, the International Code for Fire Safety Systems and the International Convention on the Control of Harmful Anti-fouling Systems on Ships; OJ L 167, 12.5.2021, p. 40

<sup>3</sup> Regulation (EU) No 528/2012 of the European Parliament and of the Council of 22 May 2012 concerning the making available on the market and use of biocidal products, OJ L 167, 27.6.2012, p. 1–123

<sup>4</sup> Commission Implementing Decision (EU) 2016/107 of 27 January 2016 not approving cybutryne as an existing active substance for use in biocidal products for product-type 21, OJ L 21, 28.1.2016, p. 81–82

available on the market up to 12 month after the date of decision. They could have similarly permitted the use up to 18 months after the date of the decision. It is to be noted that these deadlines have since expired.

In light of all of the above, the present draft Union submission falls under EU exclusive competence.<sup>5</sup> This Staff Working Document is presented to establish an EU position on the matter and to transmit the document to the IMO prior to the required deadline of 31 December 2021.<sup>6</sup>

---

<sup>5</sup> An EU position under Article 218(9) TFEU is to be established in due time should the IMO Maritime Safety Committee eventually be called upon to adopt an act having legal effects as regards the subject matter of the said draft Union submission. The concept of '*acts having legal effects*' includes acts that have legal effects by virtue of the rules of international law governing the body in question. It also includes instruments that do not have a binding effect under international law, but that are '*capable of decisively influencing the content of the legislation adopted by the EU legislature*' (Case C-399/12 Germany v Council (OIV), ECLI:EU:C:2014:2258, paragraphs 61-64). The present submission, however, does not produce legal effects and thus the procedure for Article 218(9) TFEU is not applied.

<sup>6</sup> The submission of proposals or information papers to the IMO, on issues falling under EU competence, are acts of external representation. Such submissions are to be made by an EU actor who can represent the Union externally under the Treaty, which for non-CFSP (Common Foreign and Security Policy) issues is the Commission or the EU Delegation in accordance with Article 17(1) TEU and Article 221 TFEU. IMO internal rules make such an arrangement absolutely possible as regards existing agenda and work programme items. This way of proceeding is in line with the General Arrangements for EU statements in multilateral organisations endorsed by COREPER on 24 October 2011.

## REVISION OF GUIDELINES ASSOCIATED WITH THE AFS CONVENTION AS A CONSEQUENCE OF THE INTRODUCTION OF CONTROLS ON CYBUTRYNE

**Proposal to revise the *Guidelines for brief sampling of anti-fouling systems on ships*,  
the *Guidelines for survey and certification of anti-fouling systems on ships* and the  
*Guidelines for inspection of anti-fouling systems on ships***

**Submitted by the European Commission on behalf of the European Union**

### SUMMARY

*Executive summary:* This document suggests modifications to the three guidelines associated with the AFS Convention, as a consequence of introducing controls on cybutryne:

- The *Guidelines for brief sampling of anti-fouling systems on ships* (resolution MEPC.104(49));
- The 2010 *Guidelines for survey and certification of anti-fouling systems on ships* (resolution MEPC.195(61)); and
- The 2011 *Guidelines for inspection of anti-fouling systems on ships* (resolution MEPC.208(62)).

*Strategic direction, if 2  
applicable:*

*Output:* 2.19

*Action to be taken:* Paragraph 6

*Related documents:* Resolution MEPC.104(49), Resolution MEPC.195(61), Resolution MEPC.208(62), PPR 6/INF.7, PPR 6/20, PPR 7/22, MEPC 75/18 (paragraph 10.17 and Annex 7), MEPC 76/3/3

### Background

1 The Marine Environment Protection Committee (MEPC 76) adopted the amendments to the Annex 1 of the AFS Convention at its meeting in June 2021. The controls will enter into force on 1 January 2023.

2 In view of the introduction of controls on cybutryne, three different guidelines need to be revised: Guidelines for brief sampling of anti-fouling systems on ships (resolution MEPC.104(49)); 2010 Guidelines for survey and certification of anti-fouling systems on ships (resolution MEPC.195(61)); 2011 Guidelines for inspection of anti-fouling systems on ships (resolution MEPC.208(62)).

3 This document suggests modifications to the three guidelines. Annex 1 to this document contains suggested text amendments to *Guidelines for brief sampling of anti-fouling systems on ships*. Annex 2 to this document contains suggested text amendments to the *Guidelines for inspection of anti-fouling systems on ships*. Annex 3 to this document contains suggested modifications to the *Guidelines for survey and certification of anti-fouling systems on ships*. All suggested changes have been highlighted using the standard grey shading for additions and strikethrough for deletions.

**Action requested to the sub-committee**

4 The Sub-Committee is invited to consider the information provided and take action, as appropriate.

## **Annex 1 – Suggested text amendments to the guidelines for brief sampling of anti-fouling systems on ships**

### **GUIDELINES FOR BRIEF SAMPLING OF ANTI-FOULING SYSTEMS ON SHIPS**

#### Table of contents

#### 1. General

##### Purpose

##### Structure of these Guidelines

#### 2. Definitions

#### 3. Personnel safety when sampling

##### Health

##### Safety

#### 4. Sampling and Analysis

##### Sampling methods

##### Technical aspects

##### Sampling strategy and number of samples

##### Analysis

#### 5. Thresholds and tolerance limits

##### Thresholds

##### Tolerance range

#### 6. Definition of compliance

#### 7. Documentation and recording of information

#### APPENDICES to Annex 1 - Possible methods for brief sampling and analysis of anti-fouling systems on ships

##### Method 1

##### Appendix to method 1

Record sheet for the brief sampling procedure for compliance with the Convention in terms of the presence of organotin and/or cybutryne acting as a biocide in anti-fouling systems on ship hulls

##### Method 2

##### Appendix to method 2

Record sheet for the sampling and analysis of anti-fouling systems on ship hulls - organotin and/or cybutryne compounds

## 1. General

### Purpose

1.1 Article 11 of the International Convention on the Control of Harmful Anti-fouling Systems on Ships, 2001, hereinafter referred to as "the Convention", and resolution ~~MEPC.102(48)~~ to be updated Guidelines for Survey and Certification of Anti-Fouling Systems on Ships refer to sampling as a method of verification of compliance of a ships anti fouling system with the Convention for inspection and survey.

1.2 The "Guidelines for Brief Sampling of Anti-Fouling Systems on Ships", hereinafter referred to as "the Guidelines", provide procedures for sampling to support the effectiveness of survey and inspection to ensure that a ship's anti-fouling system complies with the Convention and thus assists:

- .1 Administrations and recognized organizations (ROs) in the uniform application of the provisions of the Convention;
- .2 port State control officers with guidance on methods and handling of brief sampling in accordance with Article 11 (1)(b) of the Convention; and
- .3 companies, shipbuilders, manufacturers of anti-fouling systems, as well as any other interested parties in understanding the process of sampling as required in terms of the Convention.

1.3 However, inspections or surveys do not necessarily always need to include sampling of anti-fouling system.

1.4 These Guidelines apply to surveys and inspections of ships subject to the Convention.

1.5 The sole purpose of the sampling activities described in the Guidelines is to verify compliance with the provisions of the Convention. Consequently, such activities do not relate to any aspect not regulated by the Convention, (even if such aspects relate to the performance of an anti-fouling system on the hull of a ship, including the quality of workmanship).

### Structure of these Guidelines

1.6 These Guidelines contain:

- .1 a main body covering aspects of general nature common to "sampling" procedures related to the regulation of anti-fouling systems controlled by the Convention; and
- .2 appendices describing the unique procedures associated with the sampling and analysis of anti-fouling systems controlled by the Convention. These appendices only serve as examples of sampling and analytical methods and other sampling methods not described in an appendix may be used subject to the satisfaction of the Administration or the port State, as appropriate.

1.7 For reasons including the event of ~~other~~ further anti-fouling systems becoming controlled under the Convention, or in the light of new experience acquired, these Guidelines may need to be reviewed or amended in the future.

## 2. Definitions

For the purposes of these Guidelines:



2.1 "Administration" means the Government of the State under whose authority the ship is operating. With respect to a ship entitled to fly a flag of a State, the Administration is the Government of that State. With respect to fixed or floating platforms engaged in exploration and exploitation of the sea-bed and subsoil thereof adjacent to the coast over which the coastal State exercises sovereign rights for the purposes of exploration and exploitation of their natural resources, the Administration is the Government of the coastal State concerned.

2.2 "Anti-fouling system" means a coating, paint, surface treatment, surface or device that is used on a ship in order to control or prevent attachment of unwanted organisms.

2.3 "Threshold value" means the concentration limit of the chemical under investigation below which compliance with the relevant provisions of the Convention may be assumed.

2.4 "Company" means the owner of the ship or any other organization or person such as the manager or the bareboat charterer, who has assumed the responsibility for the operation of the ship from the owner of the ship and who, on assuming such responsibility, has agreed to take over all duties and responsibilities imposed by the International Safety Management (ISM) Code.

2.5 "Length" means the length as defined in the International Convention on Load Lines, 1966, as modified by the Protocol of 1988 relating thereto, or any successor Convention.

2.6 "Tolerance range" means the numerical range added to the threshold value indicating the range where detected concentrations above the threshold value are acceptable due to recognised analytical inaccuracy and thus do not compromise the assumption of compliance.

### **3. Personnel safety when sampling**

#### **Health**

3.1 Persons carrying out sampling should be aware that solvents or other materials used for sampling may be harmful. Wet paint which is sampled may also be harmful. In these cases the material safety data sheet (MSDS) for the solvent or paint should be read and appropriate precautions should be taken. This will normally include the wearing of long sleeve solvent resistant gloves of suitable impervious material -e.g. nitrile rubber.

3.2 Quantities of dry anti-fouling paint removed during sampling from ships' hulls will normally be too small to cause significant health effects.

#### **Safety**

3.3 Access to ships to carry out sampling safely may be difficult. If a ship is moored alongside persons carrying out sampling must ensure they have safe access to reach the hull from e.g. platforms, crane baskets, cherry-pickers, gangways. They must ensure that they are protected by railings or a climbing harness or take other precautions so that they cannot fall into the water between the quay and the ship. If in doubt a lifejacket and possibly a safety line, should be worn when sampling.

3.4 Access to ships in dry-dock should be made by secure means. Scaffolding should be securely constructed and cherry-pickers or dock-arms should be properly constructed and maintained if they are to be used to gain access. There should be a system to record the presence of the inspector in the dock area, and he should preferably be accompanied. Safety harnesses should be worn in cherry-picker baskets, if used.

### **4. Sampling and Analysis**

#### **Sampling methods**

4.1 During sampling, care should be taken not to affect the integrity or operation of the anti-fouling system.

4.2 Sampling where the anti-fouling coating is visibly damaged<sup>7</sup> or on block mark areas on the flat bottom of the ship (where the intact anti-fouling system is not applied) should be avoided. Sampling adjacent to or below areas where the anti-fouling system is damaged should also be avoided. When a sample point on the hull has been selected, any fouling present should be removed with water and a soft sponge/cloth before taking a specimen of the anti-fouling system (to avoid contamination of sample). Where possible, if carried out in dry-dock, sampling should be carried out after the hull has been water-washed.

4.3 The materials required for brief sampling methodologies should ideally be inexpensive, widely available and therefore readily accessible, irrespective of sampling conditions and/or location.

4.4 The sampling procedure should ideally be easily and reliably undertaken. Persons conducting sampling should receive appropriate training in sampling methods.

### Technical aspects

4.5 The sampling method should take into account the type of anti-fouling system used on the ship (taking into account that different parts of the hull may be treated with different anti-fouling systems);

4.6 Sampling and analysis of the ship's anti-fouling system could be related to only one or to all of the substances listed in Annex 1 of the AFS Convention. The following cases could be considered:

Case A. Analysis of organotin only

Case B. Analysis of cybutryne only

Case C. Simplified approach to detect organotin and cybutryne

4.7 Depending on the case, the number of samples, analysis, and definition of compliance will differ.

4.8 Specimens of paint for analysis during survey and certification can be taken either as wet paint<sup>8</sup> from product containers, or dry paint film sampled from the hull.

### Sampling strategy and number of samples

4.9 The sampling strategy is dependent on the precision of the sampling method, the analytical requirements, costs, and required time and the purpose of the sampling. The number

---

<sup>7</sup> During in-service periods, anti-fouling coatings on ships' hulls often become damaged. The extent of damage varies between ships and damaged areas can be visually recognised. Typically damage can be restricted to localised areas e.g. anchor chain damage (bow region), fender damage (vertical sides of hull), 'rust through areas' (underlying rust causing coating failure) or in some cases be in smaller areas scattered over larger areas of the hull (usually older ships where over-coating of original system has taken place many times).

<sup>8</sup> In order to prevent contamination, wet paint samples should be taken from a newly opened container. Paint should be stirred to ensure even consistency before sampling and all equipment used should be cleaned prior to use. Liquid paint samples should be stored in appropriate sealed packaging which will not react with or contaminate the sample. In the case of multi-component coatings (where on-site mixing of several components is required prior to application), samples of each component should be taken and the required mixing ratio recorded. When a sample of wet paint is taken from a container, details of the paint should be recorded e.g. details required for the IAFS Certificate along with a batch number for the product.

of paint specimens taken of each sample should allow for a retention quantity for back-up/storage in the event of a dispute. For dry samples, triplicate specimens of paint at each sampling point should be taken in close proximity to each other on the hull (e.g. within 10 cm of each other).

~~4.8~~ 4.10 In cases where it is recognized that more than one type of anti-fouling system is present on the hull, where access can be gained, samples should be taken from each type of system:

- .1 for survey purposes or for more thorough inspections pursuant to article 11 (2) of the Convention, in order to verify the compliance of an anti-fouling system, the number of sample points should reflect representative areas of the ship's hull; and
- .2 for inspection purposes pursuant to article 11(1) of the Convention sample points on the hull should be selected covering representative areas where the anti-fouling system is intact. Depending on the size of the vessel and accessibility to the hull, at least four sample points should be equally spaced down the length of the hull. If sampling is undertaken in dry-dock, flat bottom areas of the hull should be sampled in addition to vertical sides as different anti-fouling systems can be present on these different areas.

4.11 The distribution of any remaining anti-fouling paint in the hull surface may not be uniform. Therefore, it is important that the sampling is representative of the hull status see Guidelines for survey and certification of anti-fouling systems on ships, APPENDIX I, point 2).

## Analysis

~~4.9~~ 4.12 The analysis of the anti-fouling system should ideally involve minimal analytical effort and economic cost.

~~4.10~~ 4.13 The analysis should be conducted by a recognized laboratory meeting the ISO 17025 standard or another appropriate facility at the discretion of the Administration or the port State.

~~4.11~~ 4.14 The analytical process should be expeditious, such that results are rapidly communicated to the officers authorized to enforce the Convention.

~~4.12~~ 4.15 The analysis should produce unambiguous results expressed in units consistent with the Convention and its associated Guidelines. For example, for organotin, results should be expressed as: mg tin (Sn) per kg of dry paint and, for cybutryne: mg of cybutryne per kg of dry paint.

NOTE: Compound-specific sampling and analytical methodologies are described in the appendices to these Guidelines.

## 5. Thresholds and tolerance limits

### Thresholds

5.1 The analysis should be quantitative to the point of being able to accurately verify the threshold limits within the given tolerance.

5.2 In cases where compliance with acceptable limits, or lack thereof, is unclear, additional sampling or other methodologies for sampling should be considered.

### Tolerance range

5.3 Statistical reliability for each (compound-specific) brief sampling procedure should be documented. The analysis should be quantitative to the point of being able to accurately verify the threshold limits within the given tolerance. On the basis of these data a compound-specific tolerance range should be derived and stated compound-specific in the method description. In general, the tolerance range should not be higher than the standard deviation under typical conditions for testing and should under no circumstances go beyond 30%.

## 6. Definition of compliance

6.1 Compliance with Annex 1 of the Convention is assumed if the anti-fouling system contains:

.1 organotin at a level which does not provide a biocidal effect. In practice organotin compounds should not be present above 2,500 mg organotin (measured as Sn) per kg of dry paint.

.2 cybutryne at a level which does not provide a biocidal effect. It should not be present above 1,000 mg of cybutryne per kg of dry paint.

6.2 Compliance is largely dependent on the results of sampling and subsequent analysis. As every method of sampling and analysis has its specific accuracy, a compound-specific tolerance level may be applied in borderline cases with concentrations very close to the threshold level.

6.3 In general, compliance is assumed when the samples yield results below the threshold value.

## 7. Documentation and recording of information

7.1 The results of the sampling procedure should be fully documented on a method-specific record sheet. Examples are provided in the appendices to these Guidelines.

7.2 Such record sheets should be completed by the sampler and should be submitted to the competent authority of the Port State or Administration.

## APPENDICES to Annex 1 - Possible methods for brief sampling and analysis of anti-fouling systems on ships

### - ORGANOTIN AND/OR CYBUTRYNE -

#### METHOD 1

##### 1. Purpose of this method concerning brief sampling and analysis of anti-fouling systems

1.1 This method has been developed in order to describe a rapid methodology appropriate for the identification of anti-fouling systems on ship hulls containing organotin compounds and/or cybutryne acting as biocide. This method has been designed such that sealers should not be affected, and any underlying anti-fouling agent (or primer) is not taken up in the sampling procedure. The method is not recommended for silicon-based anti-fouling systems.

1.2 ~~This~~ The method for organotin compounds (Case A under paragraph 4.6 of the Guidelines) is based on a two-step analysis. The first step detects total tin as an indicator for organotin; the second step, detecting specific organotin compounds, is only necessary in the case of the first step proving positive.

1.3 The method for cybutryne (Case B under paragraph 4.6. of the Guidelines) is based on a one step analysis.

1.4 The simplified approach (Case C under paragraph 4.6. of the Guidelines) to detect organotin compounds and cybutryne is based on a one step analysis.

##### 2. Sampling device and materials

2.1 The sampling device is constructed in a way that only the upper layer of paint is removed, thereby and should leave any underlying paint (sealer, primer etc.) intact. This result is achieved through the use of a moving disk, (eccentric rotation) which is covered by an abrasive material like quartz or glass fibre fabric. This abrasive material has to be suitable for its use as a supporting material for the removed paint.

2.2 The device fulfils the following requirements:

- .1 the device has to work independently from any stationary power supply. The device may be driven by an electrical motor (battery-driven) or may be mechanically driven by a clockwork-like spring, provided it is able to sustain the movement over the required time period;
- .2 the applied force has to be constant during the operation, and the area for paint removal has to be defined;
- .3 the abrasive material has to be inert against chemical solvents and acids and must not contain more than trace amounts of tin or tin compounds and/or cybutryne; and
- .4 the amount of paint removed after a regular operation of the device has to be shown to exceed 20 mg per sample.

2.3 The device as described in the following section has been shown to be suitable for the brief sampling procedure. Any other device may be used however, provided such a device has proven to meet all the above-mentioned requirements.

2.4 The sampling device described here consists of a polyethylene disk, on which fibre glass fabric can be mounted by the use of an O-ring. The disk is moved on an eccentrically rotating axis.

### 3. Sampling procedure

3.1 The sampling procedure should be performed in the following manner:

- .1 control samples should be taken through the entire sampling and analytical process to account for possible contamination;
- .2 the mass of the fibre glass pads is weighed with a precision of at least 1 mg. The weight should be documented for each sample;
- .3 the fabric should be moistened thoroughly with isopropanol (0.7ml per sample) immediately before sampling;
- .4 when a sample point on the hull has been selected, any fouling present should be removed with water and a soft sponge/cloth before taking a specimen of the anti-fouling system (to avoid contamination of sample). Where possible, if carried out in dry-dock, sampling should be carried out after the hull has been water-washed;
- .5 the sampling device is then held against the surface to be sampled for a period of 5 seconds, prior to the sampling device being switched on;
- .6 the sampling device is switched on, thereby removing paint by the circular motion of the fibre glass fabric against the surface of the ship;
- .7 the sampling device should be applied to the surface of the hull for a suitable period of time, such that at least 20 mg of paint is taken up by the pad. As a general rule, if the pad colour after sampling matches the colour of the hull coating a sufficient sample has been taken;
- .8 ~~the two-step analysis procedure requires that every sample should be taken in triplicate. Two of the specimens should be labelled Specimen 'A' and Specimen 'B'. In addition a third specimen for storage/back-up should be taken. These~~ The specimens should be taken as close to each other as possible, but without overlap.
- .9 upon completion of the sampling, the fibre glass fabric pads should be left to dry, and re-weighed.
- .10 The number of samples will differ depending on the substances target as listed in Annex 1 of the AFS Convention.

Case A. Analysis of organotin only, every sample should be taken in triplicate.

Specimen 'A' – for STEP 1

Specimen 'B' – for STEP 2

Specimen 'X' – for storage/back-up

Case B. Analysis of cybutryne only, every sample should be taken in duplicate.

Specimen 'C' – for a one-step analysis

Specimen 'X' – for storage/back-up

Case C. Simplified approach to detect organotin and cybutryne, every sample should be taken in duplicate.

Specimen 'C' – for a one-step analysis  
Specimen 'X' – for storage/back-up

3.2 Samples should be stored in appropriate sealed packaging, which will not react with or contaminate the sample.

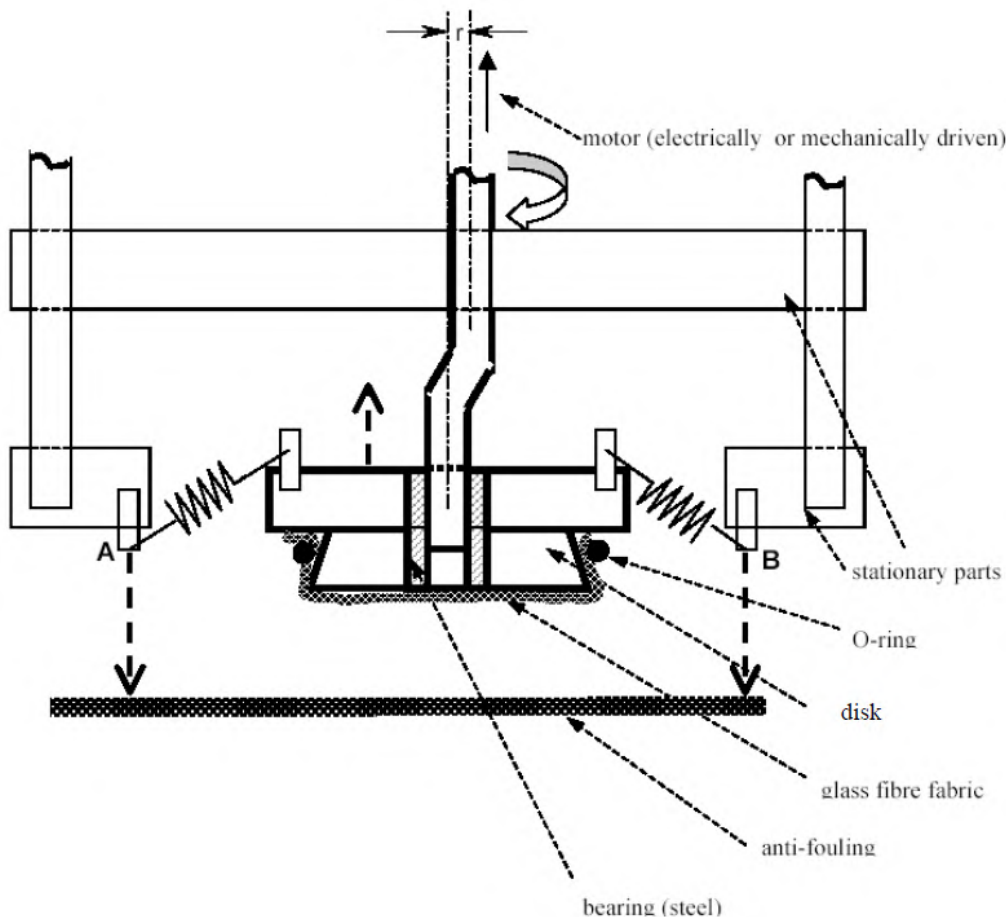

DIAGRAM A: Schematic cross section of the sampling device

The indicated points A and B are to be pressed against the surface. The polyethylene disk, covered with the glass fibre fabric, is moved with an amplitude of  $2r$  ( $r = 1,0\text{ cm}$ ) on the surface.

**Specific data:**

Force applied on the paint surface:	25N (Newton)
Effective diameter of the disk:	5cm
Frequency of rotation:	6 rotations/s
Solvent used	isopropanol (0.8ml per sample).

**4. Sampling strategy**

4.1 Sampling should be conducted in accordance with paragraph 4 of the Guidelines.

4.2 For inspection purposes in most cases accessibility to all parts of the hull will not be given. A minimum number of eight independent samples should be taken from different accessible parts of the hull.

## 5. Analytical procedure

5.1 The analytical procedure will differ depending on the substances targeted as listed in Annex 1 of the AFS Convention.

### **Case A. Analysis of organotin only**

5.4 5.2 The two components comprising the analytical procedure are illustrated in the flow diagram B. The two components, or steps, are as follows:

- .1 (STEP 1) - An analysis of Specimen A for the presence of total tin; and
- .2 (STEP 2) - A more cost- and time-consuming analysis of Specimen B, that is applied only when Step 1 produces positive results. This test involves organotin analysis by gas chromatography/mass spectrophotometry (GC/MS) after derivatisation and provides specific data on the respective organotin species.

#### **STEP 1: Investigation of total tin content in Specimen 'A'**

##### **Analysis of Specimen 'A'**

5.2 5.3 Specimen 'A' is analysed for mass of total tin per kilogram of dry paint (or mass of tin per sample) by applying inductively coupled plasma/mass spectrometry (ICP/MS), once the material had been solubilized by digestion using aqua regia. It should be noted that any other scientifically recognized procedure for tin analysis (such as AAS, XRF and ICP-OES) is acceptable.

#### **STEP 2: Characterization of organotin in Specimen 'B'**

##### **Analysis of Specimen 'B'**

5.3 5.4 Should Specimen 'A' produce positive results, organotin compounds should be identified and quantified in Specimen 'B'. Specimen 'B' may be analysed using the following procedure:

- .1 solvent extraction of Specimen 'B' as supported by sonication in an ultrasonic bath;
- .2 derivatisation with ethylmagnesium bromide;
- .3 clean-up of the extract;
- .4 analysis using high resolution gas chromatography/mass spectrophotometry (GC/MS); and
- .5 quantifications using tripropyltin as a standard.

5.5 5.5 Any equally reliable method for the chemical identification and quantification of organotin compounds is acceptable.



## **Case B. Analysis of cybutryne only**

5.6 A one-step analysis of 'Specimen C' for determining the amount of cybutryne, using gas chromatography/mass spectrophotometry (GC/MS).

### **ONE-STEP analysis: Characterisation of cybutryne in 'Specimen C'**

#### **Analysis of 'Specimen C'**

5.7 'Specimen C' should be analysed using the following procedure:

- .1 Sample extraction using ethyl acetate with added internal standard (ametryn) using an ultrasonic bath for 15 minutes;
- .2 Centrifugation of the samples at 600 rcf for 5 minutes;
- .3 Analysis of the supernatant using high resolution capillary GC/MS, with the MS operating in SIM mode;
- .4 Quantification using reference cybutryne solutions and an internal standard normalization procedure;
- .5 Modified GC/MS methods resulting in an expanded measurement uncertainty ( $k=2$ ; 95% confidence) of 25% are acceptable.

5.8 Any equally reliable method for the chemical identification and quantification of cybutryne is acceptable.

## **Case C. simplified approach to detect organotin and cybutryne**

5.9 A one-step analysis of 'Specimen C' for determining the amount of organotin and cybutryne using gas chromatography/mass spectrophotometry (GC/MS).

### **ONE-STEP analysis: Characterisation of organotin and cybutryne in 'Specimen C'**

- .1 Sample extraction using toluene with added internal standard (ametryn) using an ultrasonic bath for 15 minutes;
- .2 derivatisation with ethylmagnesium bromide;
- .3 clean-up of the extract;
- .4 Centrifugation of the samples at 600 rcf for 5 minutes;
- .5 Analysis of the supernatant using high resolution capillary GC/MS, with the MS operating in SIM mode;
- .6 Cybutryne quantification using reference cybutryne solutions and an internal standard normalization procedure. Organotin quantification using tripropyltin as the internal standard.
- .7 Modified GC/MS methods resulting in an expanded measurement uncertainty ( $k=2$ ; 95% confidence) of 25% are acceptable.

5.10 Any equally reliable method for the chemical identification and quantification of organotin and cybutryne is acceptable.

## 6. Threshold and tolerance range

6.1 The threshold value for organotin compounds for the brief sampling method as described here is:

"2,500 mg tin (Sn) per kg of dry paint."

6.2 The threshold value for cybutryne for the brief sampling method as described here is:

"1,000 mg of cybutryne per kg of dry paint."

### Tolerance range

~~6.2~~ 6.3 The tolerance range is 500 mg Sn / kg of dry paint (20%) in addition to the threshold value.

6.4 The tolerance range is 250 mg cybutryne / kg of dry paint (25%) in addition to the threshold value.

### Organotin containing compounds acting as biocides or catalysts

~~6.3~~ 6.5 As stated in the appendix of resolution MEPC.402(48) to be updated, for the purposes of defining compliance with annex 1 of the Convention, it should be noted that small quantities of organotin compounds, acting as chemical catalysts (such as mono- and di-substituted organotin compounds) are allowed, provided they are not acting as a biocide.

~~6.4~~ 6.6 Inorganic impurities in the constituents of the paints should be considered.

~~6.5~~ 6.7 At present neither organotin catalysts nor inorganic impurities are found at concentrations which will be close to the threshold level (2,500 mg Sn/kg of dry paint) or higher. However, organotin-containing compounds, when present in paint in order to act as a biocide, were found in concentrations up to 50,000mg Sn/kg of dry paint. Thus the discrimination between anti-fouling systems containing organotin compounds acting as a biocide and anti-fouling systems not containing these compounds or not containing these compounds at concentrations where they act as a biocide, is reliably possible.

## 7. Definition of compliance

7.1 The analytical verification of the compliance will differ depending on the substances targeted as listed in Annex 1 of the AFS Convention.

### Case A. Analysis of organotin only

#### Two-step procedure

~~7.1~~ 7.2 The analytical verification of the compliance with the Convention for organotin compounds is performed in a two-step procedure according to the flow-diagram (diagram B).

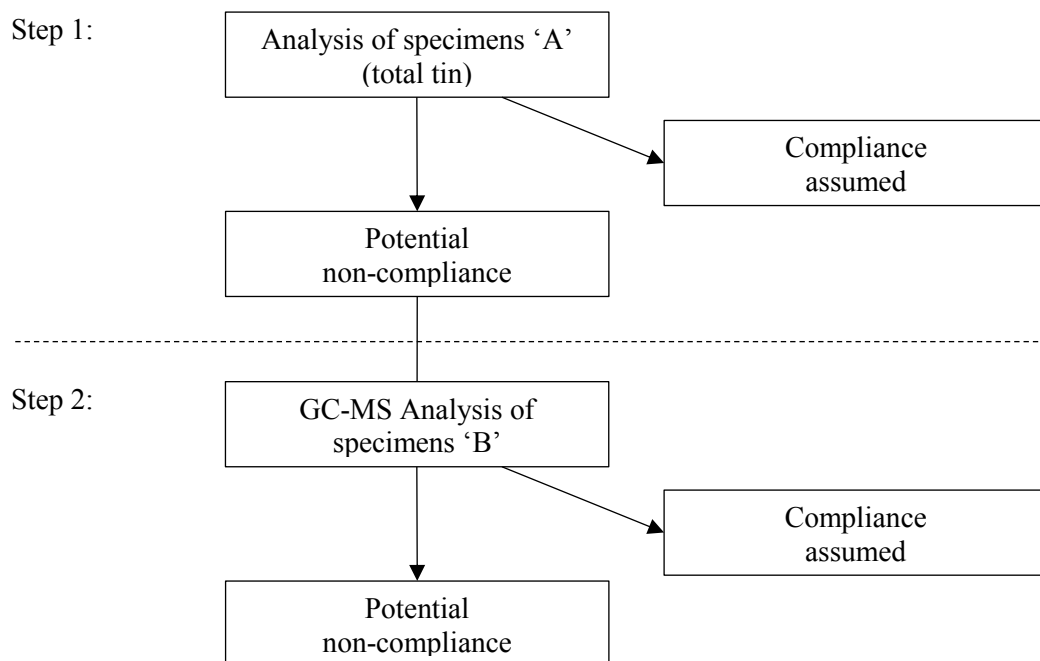

DIAGRAM B: Flow diagram illustrating the two-step analysis procedure for organotin compounds

### Compliance with the criteria at the 'STEP 1-level'

7.2 7.3 Compliance with the Convention is assumed when the results from the specimens 'A', analysed in step 1, meet the following:

- .1 no more than 25% of the total number of samples yield results above 2,500 milligrams total tin per kilogram dry paint (2,500 mg Sn/kg of dry paint); and
- .2 no sample of the total number of at least eight samples shows a concentration of total tin higher than the sum of threshold value plus the tolerance range, i.e. no sample must exceed the concentration 3,000 mg Sn/kg of dry paint.

7.3 7.4 If the results in specimen 'A' indicate that no organotin acting as biocide is present, then performing step 2 is not necessary.

### Non-compliance with the criteria at the 'STEP 1-level'

7.4 7.5 A positive result (non-compliance) is indicated if provisions of paragraph 7.23 are not met.

7.5 7.6 A positive result at step 1 (specimen 'A') would indicate that step 2 should be undertaken, and those samples labelled specimen 'B' should be analysed in order to determine and characterize the organotin present (see diagram B).

### Compliance with the criteria at the 'STEP 2-level'

7.6 7.7 Compliance with the Convention is assumed when the results from the specimens 'B', analysed in step 2, meet the following requirements at the same time:

- .1 no more than 25% of the total number of samples yield results above 2,500 milligrams total tin per kilogram dry paint (2,500 mg Sn/kg of dry paint); and
- .2 no sample of the total number of at least eight samples shows a concentration of total tin higher than the sum of threshold value plus the tolerance range, i.e., no sample must exceed the concentration 3,000 mg Sn/kg of dry paint.

### **Non-compliance at 'STEP 2-level'**

7.7 7.8 A positive result in step 2 indicates non-compliance if the provisions of paragraph 7.67 are not met. Such results should be interpreted to mean that organotin compounds are present in the anti-fouling system at a level at which it would act as a biocide.

### **Case B. Analysis of cybutryne only**

7.9 Compliance with the Convention is assumed when the results from specimen 'C', analysed in a one-step analysis for cybutryne, meet the following requirement:

- .1 The average value of the total number of specimens shows a concentration below the threshold plus the tolerance range i.e. 1,250 mg of cybutryne per kg of dry paint.

### **Non-compliance at the one-step analysis for cybutryne**

7.10 An average value of the total number of specimens showing a concentration above the threshold plus the tolerance range i.e. 1,250 mg of cybutryne per kg of dry paint indicates non-compliance.

### **Case C. Simplified approach to detect organotin and cybutryne**

7.11 Compliance with the Convention is assumed when the results from specimen 'C', analysed in a one-step analysis for organotin and cybutryne, meet the two conditions below: requirement:

- .1 For organotin, the average value of the total number of specimens shows a concentration below the threshold plus the tolerance range i.e., 3 000 mg Sn/kg of dry paint,  
and
- .2 For cybutryne, the average value of the total number of specimens shows a concentration below the threshold plus the tolerance range i.e. 1 250 mg of cybutryne per kg of dry paint

### **Non-compliance at the one-step analysis for organotin and cybutryne**

7.12 If one of the conditions set out in paragraph 7.11 above is not met, this indicates non-compliance. Such results should be interpreted to mean that cybutryne or organotin is present in the anti-fouling system at a level at which it would act as a biocide.

**APPENDIX TO METHOD 1 - RECORD SHEET FOR THE BRIEF SAMPLING PROCEDURE FOR COMPLIANCE WITH THE CONVENTION IN TERMS OF THE PRESENCE OF ORGANOTIN AND/OR CYBUTRYNE ACTING AS A BIOCIDES IN ANTI-FOULING SYSTEMS ON SHIP HULLS**

<b>RECORD SHEET: GUIDELINES FOR BRIEF SAMPLING OF ANTI-FOULING SYSTEMS ON SHIP - ORGANOTINS AND CYBUTRYNE</b>		RECORD NUMBER:
<b><u>SECTION A1: Administration</u></b>		
<b>1. Country</b>	<b>2. Name of Port</b>	<b>3. Date</b>
<b>4. Reason for sampling</b>		
<input type="checkbox"/> Port State control	<input type="checkbox"/> Survey & certification	<input type="checkbox"/> Other flag state compliance inspection
<b>5. Company details:</b>		<b>6. Inspecting official's details</b>
1. Name of ship:		1. Name:
2. Distinctive number or letters:		2. Comments:
3. Port of registry		
4. Gross tonnage:		
5. IMO number		
<b><u>SECTION B2: sampling</u></b>		
1. Time sampling procedure initiated:		
2. Description of location from where samples were taken (frame number and distance from boot topping, refer to paragraph 3.2):		
3. Number of samples taken (three <i>or two</i> specimens per sample):		
4. Photographs taken of the sample point prior to sampling?		
<input type="checkbox"/> Yes <input type="checkbox"/> No		
5. Time sampling procedure completed:		
6. Additional comments concerning sampling procedure:		

<b><u>SECTION C3: Analysis and results</u></b>
--

<b>Case A. Analysis of organotin only</b>							
<b>1. Step 1 total tin analysis:</b>							
Company name:							
Analyst responsible:				Date:			
<b>2.Specime 'A' results:</b>				Total number of specimens 'A' analysed:			
No.	mg Sn / kg	No.	mg Sn / kg	No.	mg Sn / kg	No.	mg Sn / kg
1		5		9		13	
2		6		10		14	
3		7		11		15	
4		8		12		16	
Number of specimens exceeding 2,500 mg/kg:							
1 or more specimens exceeding 3,000 mg/kg: <input type="checkbox"/> yes <input type="checkbox"/> no							
Conclusion:    Step 2 required <input type="checkbox"/>							
Compliance, Further analysis unnecessary: <input type="checkbox"/>							
<b>3. Additional comments concerning analysis of results from Specimens 'A':</b>							
<b>4. Organotin analysis undertaken by:</b>							
Company name:							
Analyst responsible:				Date:			
<b>5.Specime 'B' results:</b>				Total number of specimens 'B' analysed:			
No.	mg Sn / kg	No.	mg Sn / kg	No.	mg Sn / kg	No.	mg Sn / kg
1		5		9		13	
2		6		10		14	
3		7		11		15	
4		8		12		16	
Number of specimens exceeding 2,500 mg/kg:							
1 or more specimens exceeding 3,000 mg/kg: <input type="checkbox"/> yes <input type="checkbox"/> no							
Conclusion:    Non-compliance <input type="checkbox"/>							
Compliance, Further analysis unnecessary: <input type="checkbox"/>							
<b>6. Additional comments concerning analysis of results from Specimens 'B':</b>							

<b>Case B. Analysis of cybutryne only</b>	
<b>1. A ONE-STEP analysis using gas chromatography/mass spectrophotometry (GC/MS)</b>	
Company name:	
Analyst responsible:	Date:
<b>2.Specime 'C' results:</b>	
Total number of specimens 'C' analysed by GC-MS:	

Average concentration of cybutryne (mg of cybutryne per kg of dry paint):	
<b>3. Conclusions:</b>	
The average concentration of cybutryne exceeds the threshold of 1,250 mg of cybutryne per kg of dry paint	<input type="checkbox"/> yes <input type="checkbox"/> no
<b>4. Additional comments concerning analysis of results from Specimens 'C':</b>	

<b>Case C. Simplified approach to detect organotin and cybutryne</b>	
<b>1. A ONE-STEP analysis using gas chromatography/mass spectrophotometry (GC/MS) analysis</b>	
Company name:	
Analyst responsible:	Date:
<b>2. Specime 'C' results:</b>	
Total number of specimens 'C' analysed by GC-MS:	
Average concentration of organotin (mg Sn per kg of dry paint)	
Average concentration of cybutryne (mg of cybutryne per kg of dry paint):	
<b>3. Conclusions:</b>	
The average concentration of organotin exceeds the threshold of 3 000 mg Sn/kg of dry paint	<input type="checkbox"/> yes <input type="checkbox"/> no
The average concentration of cybutryne exceeds the threshold of 1,250 mg of cybutryne/kg of dry paint	<input type="checkbox"/> yes <input type="checkbox"/> no
<b>4. Additional comments concerning analysis of results from Specimens 'C':</b>	

<b>SECTION 4: Final conclusion</b>
<b>7. Summarised conclusion:</b>
Compliance with AFS Convention assumed <input type="checkbox"/>
Non-compliance with AFS Convention assumed <input type="checkbox"/>
<b>THIS IS TO CERTIFY that this Record is correct in all respects.</b>
<b>Issued at</b>
_____
(Place of issue of Record)
_____
(Date of issue) (Printed name and signature of authorized official issuing the Record)

(Seal or stamp of the authority/organization)



## METHOD 2

### 1. Purpose of this method

1.1 This method provides sampling and analysis procedures to identify the presence of organotin compounds and/or cybutryne in the anti-fouling systems on ships. The method is designed such that the sampling and the first stage analysis could be carried out by ship surveyors or port State control officers (PSCOs) on the survey/inspection site, e.g. at a dry dock.

1.2 This The method for organotin compounds is based on a two-stage analysis (case A under paragraph 4.6 of the Guidelines). The first stage detects total tin as an indicator for the presence of organotin and the second stage is necessary only in the case that the first stage analysis providing a positive result to detect specific organotin compounds.

1.3 The method for cybutryne analysis (case B under paragraph 4.6 of the Guidelines) is based on a one step analysis based on the gas chromatography/mass spectrophotometry analytical method (GC/MS).

1.4 A Simplified approach to detect organotin and cybutryne (case C under paragraph 4.6 of the Guidelines) is based on a one step analysis using the gas chromatography/mass spectrophotometry analytical method (GC/MS).

### 2. Sampling

2.1 The sampling is carried out by using abrasive paper rubbing on the surface of the anti-fouling system. This results in collection of paint fragment of the anti-fouling system from thin area, less than several micrometer in depth from the surface, which do not affect the coatings lying underneath such as sealers.

2.2 Abrasive paper is pasted on a disc of approximately 10 mm in diameter. Rubbing the surface of the anti-fouling system with the disc collects several milligrams of the sample on to the abrasive paper.

2.3 The sampling device consists of an electric motor, two (or three) rotating rods on each of which a disc is attached, and a battery for electric power supply. The discs are pressed on to the surface of ship's hull by spring coils. The disks rotate counter-clockwise while the rods turn clockwise around the centre of the device. Schematic diagram is illustrated in figure 1.

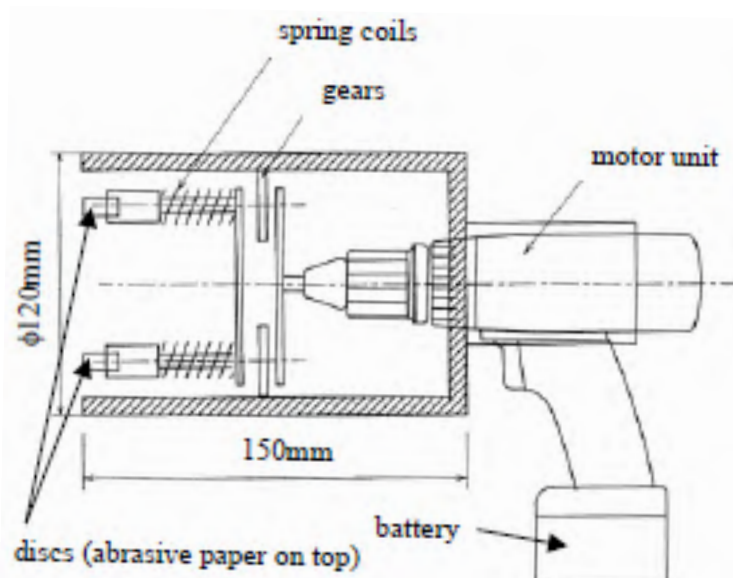

Figure 1. Schematic diagram of sampling device

2.4 Sampling point is selected such that the anti-fouling system is intact over an area of approximately 50 cm x 50 cm or more.

2.5 Depending on the substances targeted as listed in Annex 1 of the AFS Convention:

- A. For the analysis of organotin only, at each sampling point, three sets of sampling, or more if necessary, should be carried out to obtain at least six specimens.
- B. For the analysis of cybutryne only, at each sampling point, three sets of sampling, or more if necessary, should be carried out to obtain at least six specimens.
- C. For the analysis of organotin and cybutryne, at each sampling point, three sets of sampling, or more if necessary, should be carried out to obtain at least six specimens.

2.5 2.6 The device is pressed on the ship's hull where it is appropriate to be sampled and held by hand. The electric motor is switched on to slide along the painted surface to lightly scrape off the fragments of the paint onto the abrasive paper. After the sample collection, each disc is removed from the device and stored in an inert container.

2.6 2.7 Sampling should normally be carried out with the sampling device. However, in the case that accessibility to the sampling point is poor, it is acceptable to collect samples with the discs by hand if necessary.

### **3. Analysis**

#### **Case A. Analysis of organotin only**

3.1 The first-stage analysis

- .1 The first-stage analysis is assumed to be carried out on the spot of the survey or inspection, e.g. dry docks and sea ports. In order to accomplish the on-site analysis, X-ray fluorescence analysis (XRF) is used in this method to detect total tin content.
- .2 Analytical characteristics, such as detection limit and accuracy, are highly dependent on the type of the instrument, i.e. type of X-ray tube, spectrometer, optical arrangement (filters or collimators), etc. Among several types of the XRF instruments, an energy-dispersive spectrometer with a silicon drift detector (SDD), which is compact in size and be able to be operated without liquid nitrogen, is preferable to the present analytical system for a field use, whereas wave-length dispersion system or solid-state detector are also available if the analysis carried out at laboratories.
- .3 Software customized for the tin analysis is prepared to assist the operator, who is assumed to be a ship surveyor or PSCO, to detect total tin in the specimens.
- .4 The customized software may in advance need a calibration curve of the characteristic X-ray intensity of tin in relation to the tin content particularly in the range of 0.1 to 0.5%.

- .5 After the preparation including the warming-up of the XRF instrument and starting-up of the computer, a specimen (sampling disc) is placed on the sample stage of the instrument. Afterwards, analysis is executed by the customized software. A single batch of analysis for one specimen normally takes 5 minutes and the result is shown on a display automatically.
6. Since the XRF analysis does not affect any properties of the specimens, all of the collected specimens (six to nine specimens), including those for the second analysis and storage, are able to be used for this analysis.

#### 4- 3.2 Interpretation of the result at the first-stage analysis

- .1 Following the procedures above, XRF data of six, or nine, specimens are obtained for each sampling point. Omitting the maximum and minimum values from the data, an average of the tin content is calculated from the intermediate values for the representing value of the sampling point.
- .2 Compliance with the Convention is assumed when none of the tin contents (average values) from the samples do not exceed the sum of the threshold (2,500 mg per kg) and a tolerance (500 mg per kg).
- .3 When one or more average values of samples from different sampling points do not meet the above criteria, the samples should be sent to a laboratory for the second stage analysis. Regardless of the results, it is also possible to undergo the second stage analysis when the surveyor or PSCO considers that it is necessary to do so.

#### 5-3.3 Second-stage analysis

- .1 Since the second-stage analysis provides the final and definitive results of the samples, the method should be thoroughly reviewed by experts based on scientific evidence. The following is a brief summary of a tentative methodology for the second stage analysis.
- .2 The collected paint specimens are removed from the abrasive paper and total mass is measured with an electronic balance to an order of 0.1 mg. The specimens are hydrolysed with sodium hydroxide aqueous solution, extracted with organic solvent, and then derivatised with propylmagnesium bromide. After cleaning up the extract, analysis using high resolution gas chromatography/mass spectrometry (GC/MS) is carried out. For quantification analysis, tetrabutyl tin d36 is added as the internal standard.
- .3 These analyses provide the data of chemical species and their content (mg per kg of the specimens). The content of organotin is obtained in a unit of mg per kg of dry paint.

#### **Case B. For the analysis of cybutryne only**

3.4 The collected paint specimens are removed from the abrasive paper and total mass is measured with an electronic balance to an order of 0.1 mg. The following procedure is proposed for determining the concentration of cybutryne:

- .1 Sample extraction using ethyl acetate with added internal standard (ametryn) using an ultrasonic bath for 15 minutes;
- .2 Centrifugation of the samples at 600 rcf for 5 minutes;

- .3 Analysis of the supernatant using high resolution capillary GC/MS, with the MS operating in SIM mode;
- .4 Quantification using reference cybutryne solutions and an internal standard normalization procedure;
- .5 Modified GC/MS methods resulting in an expanded measurement uncertainty ( $k=2$ ; 95% confidence) of 25% are acceptable.

### **Case C. Simplified approach to detect organotin and cybutryne**

3.5 The collected paint specimens are removed from the abrasive paper and total mass is measured with an electronic balance to an order of 0.1 mg. The following procedure is proposed for determining the concentration of organotin and cybutryne:

- .1 Sample extraction using toluene with added internal standard (ametryn) using an ultrasonic bath for 15 minutes;
- .2 Addition of sodium hydroxide aqueous solution to hydrolyse the sample and to facilitate the extraction to the toluene.
- .3 Centrifugation of the samples at 600 rcf for 5 minutes;
- .4 Collection of the supernatant and derivatisation with propylmagnesium bromide
- .5 clean-up of the extract;
- .6 Analysis of the toluene solution using high resolution capillary GC/MS, with the MS operating in SIM mode;
- .7 Cybutryne quantification using reference cybutryne solutions and an internal standard normalization procedure; Organotin quantification using tetrabutyl tin d36 is added as the internal standard
- .8 Modified GC/MS methods resulting in an expanded measurement uncertainty ( $k=2$ ; 95% confidence) of 25% are acceptable.

## **6.4. Compliance with the Convention**

### **Case A. Analysis of organotin only**

6.4 4.1 Compliance with the Convention for organotin compounds is assumed when the results from the second-stage analysis meet the following requirements at the same time:

- .1 no more than 25% of the total number of samples yield results above 2,500 milligrams tin as organic form per kilogram dry paint (2,500 mg Sn/kg of dry paint); and
- .2 no sample of the total number of specimens shows a concentration of tin as organic form higher than the sum of the threshold value plus the tolerance range, i.e., no sample must exceed the concentration 3,000 mg Sn/kg dry paint.

6.4 4.2 When the result does not meet the above criteria, it is interpreted to mean that organotin compounds are present in the anti-fouling system at a level where they would act as a biocide.

### **Case B. Analysis of cybutryne only**

4.3 Compliance with the Convention for cybutryne is assumed when the results from the cybutryne analysis meets the following criteria:

.1 The average value of the total number of specimens shows a concentration below the threshold plus the tolerance range i.e. 1,250 mg of cybutryne per kg of dry paint.

4.4 When the result does not meet the above criteria, it is interpreted to mean that cybutryne is present in the anti-fouling system at a level where they would act as a biocide.

#### **Case C. simplified approach to detect organotin and cybutryne**

4.5 Compliance with the Convention for organotin compounds and cybutryne is assumed when the results from the cybutryne and organotin analysis meets the two conditions below:

.1 For organotin, the average value of the total number of specimens shows a concentration below the threshold plus the tolerance range i.e., 3 000 mg Sn/kg of dry paint.

and

.2 For cybutryne, the average value of the total number of specimens shows a concentration below the threshold plus the tolerance range i.e. 1,250 mg of cybutryne per kg of dry paint.

4.6 When the results do not meet one of the conditions above, it is interpreted to mean that organotin compounds or cybutryne is present in the anti-fouling system at a level where they would act as a biocide.

**APPENDIX TO METHOD 2**

**Record sheet for the sampling and analysis of anti-fouling systems on ship hulls - organotin compounds and/or cybutryne**

Record Number:
----------------

<b>Section A 1: Administration</b>	
1. Country	2. Location
3. Date	
4. Reason for Survey/Inspection	
5. Details of the ship	
5.1 Name of Ship	
5.2 Distinctive Number or letters	
5.3 Gross tonnage	5.4. Year of built
5.5 Owner or Operator of Ship	
5.6 Flag State	5.7 Class of ship
5.8 Authority of AFS certificate	
5.9 Date of Issue	
5.10 Date of last endorsement	
5.11 IMO number	
5.12 Name of shipmaster	
5.13 Product Name of Anti-fouling system	
5.14 Name of manufacturer	
5.15 Name of Shipyard where applied	
5.16 Comments	
6. Inspecting Official's Details	
6.1 Name	
6.2 Comments	

**Section 2 – Sampling and analysis**  
**Case A. Analysis of organotin only**

Record Number

**Section B: Sampling and Stage 1-one Analysis (X-ray Fluorescence Analysis)**

Date: Instrument I.D.

Sample location	Specimen I.D.	Sample Disc	Content of Tin (mg/ kg)	max	min	Average
<b>A</b>	A1	<input type="checkbox"/> abrasive				Average  mg/kg <input type="checkbox"/> >2,500 mg/kg <input type="checkbox"/> >3,000 mg/kg
	A2	<input type="checkbox"/> metal				
	A3	<input type="checkbox"/> others				
	A4	<input type="checkbox"/> abrasive				
	A5	<input type="checkbox"/> metal				
	A6	<input type="checkbox"/> others				
	A7	<input type="checkbox"/> abrasive				
	A8	<input type="checkbox"/> metal				
	A9	<input type="checkbox"/> others				
<b>B</b>	B1	<input type="checkbox"/> abrasive				Average  mg/kg <input type="checkbox"/> >2,500 mg/kg <input type="checkbox"/> >3,000 mg/kg
	B2	<input type="checkbox"/> metal				
	B3	<input type="checkbox"/> others				
	B4	<input type="checkbox"/> abrasive				
	B5	<input type="checkbox"/> metal				
	B6	<input type="checkbox"/> others				
	B7	<input type="checkbox"/> abrasive				
	B8	<input type="checkbox"/> metal				
	B9	<input type="checkbox"/> others				
<b>C</b>	C1	<input type="checkbox"/> abrasive				Average  mg/kg <input type="checkbox"/> >2,500 mg/kg <input type="checkbox"/> >3,000 mg/kg
	C2	<input type="checkbox"/> metal				
	C3	<input type="checkbox"/> others				
	C4	<input type="checkbox"/> abrasive				
	C5	<input type="checkbox"/> metal				
	C6	<input type="checkbox"/> others				
	C7	<input type="checkbox"/> abrasive				
	C8	<input type="checkbox"/> metal				
	C9	<input type="checkbox"/> others				
<b>D</b>	D1	<input type="checkbox"/> abrasive				Average  mg/kg <input type="checkbox"/> >2,500 mg/kg <input type="checkbox"/> >3,000 mg/kg
	D2	<input type="checkbox"/> metal				
	D3	<input type="checkbox"/> others				
	D4	<input type="checkbox"/> abrasive				
	D5	<input type="checkbox"/> metal				
	D6	<input type="checkbox"/> others				
	D7	<input type="checkbox"/> abrasive				
	D8	<input type="checkbox"/> metal				
	D9	<input type="checkbox"/> others				

<input type="checkbox"/> Stage II required	<input type="checkbox"/> samples out of _____ are above 2,500 mg/kg <input type="checkbox"/> sample(s) _____ is (are) above 3,000 mg/kg	<input type="checkbox"/> Compliant
--	--	------------------------------------

Sampled by	Analysed by
Signature	Signature

Record Number:

<b>Section C: Stage II two Analysis (Gas Chromatography Mass Spectrometry)</b>				
Date				
Instrument I.D.				
Comments on the method				
Sample I.D.	Specimen Used	Content of Tin (XFR analysis) (mg/kg)	Content of Tin (as organotin) (mg/kg)	Compliance
A				<input type="checkbox"/> >2,500 mg/kg <input type="checkbox"/> >3,000 mg/kg
B				<input type="checkbox"/> >2,500 mg/kg <input type="checkbox"/> >3,000 mg/kg
C				<input type="checkbox"/> >2,500 mg/kg <input type="checkbox"/> >3,000 mg/kg
D				<input type="checkbox"/> >2,500 mg/kg <input type="checkbox"/> >3,000 mg/kg
4. Conclusion <input type="checkbox"/> Not compliant _____ samples out of _____ are above 2,500 mg/kg <input type="checkbox"/> Not compliant sample(s) _____ is (are) above 3,000 mg/kg <input type="checkbox"/> Compliant				
5. Additional comments				
6. Laboratory Name				
7. Analysed by			8. Signature	



**Case B. Analysis of cybutryne only**

Record Number

**Sampling and Gas Chromatography Mass Spectrometry analysis**

Date:

Instrument I.D.

Sample location	Specimen I.D.	Sample Disc	Comments to the samples and sampling procedure	Comments to the sample location
<b>A</b>	A1	<input type="checkbox"/> abrasive		
	A2	<input type="checkbox"/> metal		
	A3	<input type="checkbox"/> others		
	A4	<input type="checkbox"/> abrasive		
	A5	<input type="checkbox"/> metal		
	A6	<input type="checkbox"/> others		
	A7	<input type="checkbox"/> abrasive		
	A8	<input type="checkbox"/> metal		
	A9	<input type="checkbox"/> others		
<b>B</b>	B1	<input type="checkbox"/> abrasive		
	B2	<input type="checkbox"/> metal		
	B3	<input type="checkbox"/> others		
	B4	<input type="checkbox"/> abrasive		
	B5	<input type="checkbox"/> metal		
	B6	<input type="checkbox"/> others		
	B7	<input type="checkbox"/> abrasive		
	B8	<input type="checkbox"/> metal		
	B9	<input type="checkbox"/> others		
<b>C</b>	C1	<input type="checkbox"/> abrasive		
	C2	<input type="checkbox"/> metal		
	C3	<input type="checkbox"/> others		
	C4	<input type="checkbox"/> abrasive		
	C5	<input type="checkbox"/> metal		
	C6	<input type="checkbox"/> others		
	C7	<input type="checkbox"/> abrasive		
	C8	<input type="checkbox"/> metal		
	C9	<input type="checkbox"/> others		
<b>D</b>	D1	<input type="checkbox"/> abrasive		
	D2	<input type="checkbox"/> metal		
	D3	<input type="checkbox"/> others		
	D4	<input type="checkbox"/> abrasive		
	D5	<input type="checkbox"/> metal		
	D6	<input type="checkbox"/> others		
	D7	<input type="checkbox"/> abrasive		
	D8	<input type="checkbox"/> metal		
	D9	<input type="checkbox"/> others		

Average concentration of cybutryne (mg of cybutryne per kg of dry paint)

Sampled by

Analysed by

Signature

Signature

**Case C. Simplified approach to detect organotin and cybutryne**

	Record Number
Sampling and Gas Chromatography Mass Spectrometry analysis	
Date:	Instrument I.D.

Sample location	Specimen I.D.	Sample Disc	Comments to the samples and sampling procedure	Comments to the sample location
<b>A</b>	A1	<input type="checkbox"/> abrasive		
	A2	<input type="checkbox"/> metal		
	A3	<input type="checkbox"/> others		
	A4	<input type="checkbox"/> abrasive		
	A5	<input type="checkbox"/> metal		
	A6	<input type="checkbox"/> others		
	A7	<input type="checkbox"/> abrasive		
	A8	<input type="checkbox"/> metal		
	A9	<input type="checkbox"/> others		
<b>B</b>	B1	<input type="checkbox"/> abrasive		
	B2	<input type="checkbox"/> metal		
	B3	<input type="checkbox"/> others		
	B4	<input type="checkbox"/> abrasive		
	B5	<input type="checkbox"/> metal		
	B6	<input type="checkbox"/> others		
	B7	<input type="checkbox"/> abrasive		
	B8	<input type="checkbox"/> metal		
	B9	<input type="checkbox"/> others		
<b>C</b>	C1	<input type="checkbox"/> abrasive		
	C2	<input type="checkbox"/> metal		
	C3	<input type="checkbox"/> others		
	C4	<input type="checkbox"/> abrasive		
	C5	<input type="checkbox"/> metal		
	C6	<input type="checkbox"/> others		
	C7	<input type="checkbox"/> abrasive		
	C8	<input type="checkbox"/> metal		
	C9	<input type="checkbox"/> others		
<b>D</b>	D1	<input type="checkbox"/> abrasive		
	D2	<input type="checkbox"/> metal		
	D3	<input type="checkbox"/> others		
	D4	<input type="checkbox"/> abrasive		
	D5	<input type="checkbox"/> metal		
	D6	<input type="checkbox"/> others		
	D7	<input type="checkbox"/> abrasive		
	D8	<input type="checkbox"/> metal		
	D9	<input type="checkbox"/> others		

Average content of organotin (mg of organotin per kg of dry paint)			
Average concentration of cybutryne (mg of cybutryne per kg of dry paint)			
Sampled by	Analysed by		
Signature	Signature		

## **Section D 3: Final Conclusion**

### 1. Conclusion

- Anti-fouling system is compliant with the AFS Convention 2001.
- Anti-fouling system is NOT compliant with the AFS Convention 2001.

### 2. Comments

### 3. Processed Official

3.1 Name

3.2 Date

3.3 Signature

### 4. Authorized Administrator

4.1 Name

4.2 Date

4.3 Signature

## Annex 2 – Suggested text amendments to the guidelines for inspection of antifouling systems on ships

### 2014 GUIDELINES FOR INSPECTION OF ANTI-FOULING SYSTEMS ON SHIPS

#### 1 INTRODUCTION

1.1 The right of the port State to conduct inspections of anti-fouling systems on ships is **laid down** in Article 11 of the AFS Convention. The guidelines for conducting these inspections are described below.

1.2 Ships of 400 gross tonnage and above engaged in international voyages (excluding fixed or floating platforms, FSUs and FPSOs) will be required to undergo an initial survey before the ship is put into service or before the International Anti-fouling System Certificate (IAFS) is issued for the first time; and a survey should be carried out when the anti-fouling systems are changed or replaced.

1.3 Ships of 24 metres in length or more but less than 400 gross tonnage engaged in international voyages (excluding fixed or floating platforms, FSUs and FPSOs) will have to carry a Declaration on Anti-fouling Systems signed by the owner or authorized agent. Such declaration shall be accompanied by appropriate documentation (such as a paint receipt or a contractor invoice) or contain appropriate endorsement.

#### 2 INITIAL INSPECTION

##### 2.1 Ships required to carry an IAFS Certificate or Declaration on Anti-Fouling Systems (Parties of the AFS Convention)

2.1.1 The PSCO should check the validity of the IAFS Certificate or Declaration on Anti-Fouling Systems, and the attached Record of Anti-Fouling Systems, if appropriate.

2.1.2 The only practical way to apply paint to the ship's bottom (underwater part) is in a dry dock. This means that the date of application of paint on the IAFS Certificate should be checked by comparing the period of dry-docking with the date on the certificate.

2.1.3 If the paint has been applied during a scheduled dry-dock period, it has to be registered in the ship's logbook (~~in order to be legal~~). Furthermore, this scheduled dry-docking can be verified by the endorsement date on the (statutory) Cargo Ship Safety Construction Certificate or the Safety Construction Certificate (SOLAS, regulation I/10) and Passenger Ship Safety Certificate (SOLAS, regulation I/7).

2.1.4 In case of an unscheduled dry-dock period, it could be verified by the registration in the ship's logbook (~~in order to be legal~~).

2.1.5 It can be additionally verified by the endorsement date on the (Class) Hull Certificate, the dates on the Manufacturer's Declaration or by confirmation of the shipyard.

2.1.6 The IAFS Certificate includes a series of tick boxes indicating **for each of the anti-fouling systems, describing the following situations:**

- .1 if an anti-fouling system controlled under Annex 1 of the AFS Convention has ~~or has not been applied during or after construction of this ship, removed or been covered with a sealer coat;~~
- .2 if an anti-fouling system controlled under Annex 1 of the AFS Convention ~~was applied on the ship prior to 1 January 2003 or a later date if specified by the~~

Administration has been applied on this ship previously, but has been removed; and;

- .3 if an anti-fouling system controlled under Annex 1 of the AFS Convention was applied on the ship on/after 1 January 2003 or a later date if specified by the Administration. has been applied on this ship previously, but has been covered with a sealer coat;
- .4 if an anti-fouling system controlled under Annex 1 of the AFS Convention has been applied on this ship previously, but is not in the external coating layer of the hull or external parts or surfaces on 1 January 2023; and
- .5 if an anti-fouling system controlled under Annex 1 of the AFS Convention was applied on this ship prior to date 1 January 2023, but must be removed or covered with a sealer coat no later than 60 months following the last application to the ship of an anti-fouling systems containing cybutryne.

2.1.7 Particular attention should be given to verifying that the survey for issuance of the current IAFS Certificate matches the dry-dock period listed in the ship's log(s) and that only one tick box is marked for each of the substances controlled under Annex 1.

2.1.8 The Record of Anti-Fouling Systems should be attached to the IAFS Certificate and be up to date. The most recent record should agree with the tick box on the front of the IAFS Certificate. The issuing of the IAFS certificate should be in accordance with Regulation 2(3) of Annex 4 of the AFS Convention.

## **2.2 Ships of non-Parties to the AFS Convention**

2.2.1 Ships of non-Parties to the AFS Convention are not entitled to be issued with an IAFS Certificate. Therefore the PSCO should ask for documentation that contains the same information as in an IAFS Certificate and take this into account in determining compliance with the requirements.

2.2.2 If the existing anti-fouling system is declared not to be controlled under Annex 1 of the Convention, without being documented by an International Anti-Fouling System Certificate, verification should be carried out to confirm that the anti-fouling system complies with the requirements of the Convention. This verification may be based on sampling and/or testing and/or reliable documentation, as deemed necessary, based on experience gained and the existing circumstances. Documentation for verification could be, e.g., MSDSs (Material Safety Data Sheets), or similar, a declaration of compliance from the anti-fouling system manufacturer, invoices from the shipyard and/or the anti-fouling system manufacturer.

2.2.3 Ships of non-Parties may have Statements of Compliance issued in order to comply with regional requirements, for example, Regulation (EC) 782/2003 as amended by Regulation (EC) 536/2008, which could be considered as providing sufficient evidence of compliance for organotin compounds.

2.2.4 In all other aspects the PSCO should be guided by the procedures for ships required to carry an IAFS Certificate.

2.2.5 The PSCO should ensure that no more favourable treatment is applied to ships of non-Parties to the AFS Convention.

## **3 MORE DETAILED INSPECTION**

### **3.1 Clear ground**

3.1.1 A more detailed inspection may be carried out when there has been clear grounds to believe that the ship does not substantially meet the requirements of the AFS Convention. Clear grounds for a more detailed inspection may be when:

- .1 the ship is from a flag of a non-Party to the Convention and there is no AFS documentation;
- .2 the ship is from a flag of a Party to the Convention but there is no valid IAFS Certificate;
- .3 the painting date shown on the IAFS Certificate does not match the dry-dock period of the ship;
- .4 the ship's hull shows excessive patches of different paints; and
- .5 the IAFS Certificate is not properly completed.

3.1.2 If the IAFS Certificate is not properly completed, the following questions may be pertinent:

- .1 "When was the ship's anti-fouling system last applied?";
- .2 "If the anti-fouling system is controlled under Annex 1 to the AFS Convention and was removed, what was the name of the facility and date of the work performed?";
- .3 "If the anti-fouling system is controlled under Annex 1 of the AFS Convention and has been covered by a sealer coat, what was the name of the facility and date applied?";
- .4 "What is the name of the anti-fouling/sealer products and the manufacturer or distributor for the existing anti-fouling system?"; and
- .5 "If the current anti-fouling system was changed from the previous system, what was the type of anti-fouling system and name of the previous manufacturer or distributor?".

## **3.2 Sampling**

3.2.1 A more detailed inspection may include sampling and analysis of the ship's anti-fouling system, if necessary, to establish whether or not the ship complies with the AFS Convention. Such sampling and analysis may involve the use of laboratories and detailed scientific testing procedures.

3.2.2 If sampling is carried out, the time to process the samples cannot be used as a reason to delay the ship.

3.2.3 Any decision to carry out sampling should be subject to practical feasibility or to constraints relating to the safety of persons, the ship or the port (see appendix 1 for sampling procedures; an AFS Inspection Report template for sampling and analysis is attached to the Guidelines).

## **3.3 Action taken under the AFS Convention**

### **Detention**

3.3.1 The port State could decide to detain the ship following detection of deficiencies during an inspection on board.

3.3.2 Detention could be appropriate in any of the following cases:

- .1 certification is invalid or missing;
- .2 the ship admits it does not comply (thereby removing the need to prove by sampling); and
- .3 sampling proves it is non-compliant within the ports jurisdiction.

3.3.3 Further action would depend on whether the problem is with the certification or the anti-fouling system itself.

3.3.4 If there are no facilities in the port of detention to bring the ship into compliance, the port State could allow the ship to sail to another port to bring the anti-fouling system into compliance. This would require an agreement of that port.

### **Dismissal**

3.3.5 The port State could dismiss the ship, meaning that the port State demands that the ship leaves port – for example if the ship chooses not to bring the AFS into compliance but the port State is concerned that the ship is leaching tributyltin (TBTs) or cybutryne into its waters.

3.3.6 Dismissal could be appropriate if the ship admits it does not comply or sampling proves it is non-compliant while the ship is still in port. Since this would also be a detainable deficiency the PSCO can detain first and require rectification before release. However, there may not be available facilities for rectification in the port of detention. In this case the port State could allow the ship to sail to another port to bring the anti-fouling system into compliance. This could require agreement of that port.

3.3.7 Dismissal could be appropriate in any of the following cases:

- .1 certification is invalid or missing;
- .2 the ship admits it does not comply (thereby removing the need to collect proof by sampling); and
- .3 sampling proves that the ship is non-compliant within the ports jurisdiction.

3.3.8 In these cases the ship will probably already have been detained. However, detention does not force the ship to bring the AFS into compliance (only if it wants to depart). In such a situation the port State may be concerned that the ship is leaching TBTs or cybutryne while it remains in its waters.

### **Exclusion**

3.3.9 The port State could decide to exclude the ship to prevent it entering its waters. Exclusion could be appropriate if sampling proves that the ship is non-compliant but the results have been obtained after it has sailed or after it has been dismissed.

3.3.10 Exclusion could be appropriate if sampling proves that the ship is non-compliant but the results have been obtained after it has sailed or after it has been dismissed. Article 11(3) of the AFS Convention only mentions that the "party carrying out the inspection" may take such steps. This means that, if a port State excludes a ship, the exclusion cannot be automatically applied by other port States.

3.3.11 In accordance with Procedures for Port State Control (resolution A.787(19) A.1138(31), as amended), where deficiencies cannot be remedied at the port of inspection, the PSCO may allow the ship to proceed to another port, subject to any appropriate conditions determined. In such circumstances, the PSCO should ensure that the competent authority of the next port of call and the flag State are notified.

### **Reporting to flag State**

3.3.12 Article 11(3) of the AFS Convention requires that when a ship is detained, dismissed or excluded from a port for violation of the Convention, the Party taking such action shall immediately inform the flag Administration of the ship and any Recognized Organization which has issued a relevant certificate.

## **4 AFS REPORT TO FLAG STATE IN RESPONSE TO ALLEGED CONTRAVENTIONS**

4.1 Article 11(4) of the AFS Convention allows Parties to inspect ships at the request of another Party, if sufficient evidence that the ship is operating or has operated in violation of the Convention is provided. Article 12(2) permits port States conducting the inspection to send the Administration (flag State) of the ship concerned any information and evidence it has that a violation has occurred. Information sent to the flag State is often inadequate for a prosecution. The following paragraphs detail the sort of information needed.

4.2 The report to the authorities of the port or coastal State should include as much as possible the information listed in section 3. The information in the report should be supported by facts which, when considered as a whole, would lead the port or coastal State to believe a contravention had occurred.

4.3 The report should be supplemented by documents such as:

- .1 the port State report on deficiencies;
- .2 a statement by the PSCO, including his rank and organization, about the suspected non-conforming anti-fouling system. In addition to the information required in section 3, the statement should include the grounds the PSCO had for carrying out a more detailed inspection;
- .3 a statement about any sampling of the anti-fouling system including:
  - .1 the ship's location;
  - .2 where the sample was taken from the hull, including the vertical distance from the boot topping;
  - .3 the time of sampling;
- .4 person(s) taking the samples; and
- .5 receipts identifying the persons having custody and receiving transfer of the samples;
- .4 reports of the analyses of any samples including:
  - .1 the results of the analyses;
  - .2 the method employed;



- .3 reference to or copies of scientific documentation attesting the accuracy and validity of the method employed;
- .4 the names of persons performing the analyses and their experience; and
- .5 a description of the quality assurance measures of the analyses;
- .5 statements of persons questioned;
- .6 statements of witnesses;
- .7 photographs of the hull and sample areas; and
- .8 a copy of the IAFS Certificate, including copies of relevant pages of the Record of Anti-fouling Systems, log books, MSDS or similar, declaration of compliance from the anti-fouling system manufacturer, invoices from the shipyard and other dry dock records pertaining to the anti-fouling system.

4.4 All observations, photographs and documentation should be supported by a signed verification of their authenticity. All certifications, authentications or verifications should be in accordance with the laws of the State preparing them. All statements should be signed and dated by the person making them, with their name printed clearly above or below the signature.

4.5 The reports referred to under paragraphs 2 and 3 of this section should be sent to the flag State. If the coastal State observing the contravention and the port State carrying out the investigation on board are not the same, the port State carrying out the investigation should also send a copy of its findings to the coastal State.

## APPENDIX 1 to Annex 2

### SAMPLING

Considerations related to brief sampling may be found in section 2.1 of Guidelines for brief sampling of anti-fouling systems on ships (~~resolution MEPC.104(49)~~ (to be updated)).

Any obligation to take a sample should be subject to practical feasibility or to constraints relating to the safety of persons, the ship or the port.

The PSCO should consider the following:

- liaise with the ship on the location and time needed to take samples; the PSCO should verify that the time required will not unduly prevent the loading/unloading, movement or departure of the ship;
- do not expect the ship to arrange safe access but liaise with the ship over the arrangements that the port State competent authority has made, for example boat, cherry-picker, staging, etc.;
- select sampling points covering representative areas;
- take photographs of the hull, sample areas and sampling process;
- avoid making judgements on the quality of the paint (e.g., surface, condition, thickness, application);
- the need of inviting the ship representative's presence during brief sampling to ensure that the evidence is legally obtained;
- complete and sign the inspection report form together with the included sampling record sheets (to be filled in by the sampler), as far as possible, and leave a copy with the ship as a proof of inspection/sampling;
- inform the next port State where the inspected ship is to call;
- agree with or advise the ship on to whom the ship's copy of the finalized inspection report will be sent in cases when it cannot be completed in the course of the inspection; and
- ensure that receipts identifying the persons having custody and receiving transfer of the samples accompany the samples are filled in to reflect the transfer chain of the samples. PSCOs are reminded that the procedures set in national legislation regarding custody of evidence are not affected by the regulation. These guidelines therefore do not address this issue in detail.

#### 1 Sampling methodologies

It is to the discretion of the port State to choose the sampling methodology. The Guidelines for brief sampling of anti-fouling systems on ships adopted by ~~resolution MEPC.104(49)~~ (to be updated) allow that any other scientifically recognized method of sampling and analysis of AFS controlled by ~~under~~ the Convention than those described in the appendix to the Guidelines may be used (subject to the satisfaction of the Administration or the port State). The sampling methodology will depend, *inter alia*, on the surface hardness of the paint, which may vary considerably. The amount of paint mass removed may vary correspondingly.

Based on the on-board International Anti-fouling System Certificate or a Declaration on Anti-fouling System, the port state competent authority would decide if the brief sampling analysis should focus on only organotin, cybutryne or both and apply the appropriate methodology including: the number of samples, analysis, and definition of compliance.

Sampling procedures, based on the removal of paint material from the hull, require the determination of paint mass. It is important that procedures used are validated, produce unambiguous results and contain an adequate control.

The competent port State authority can decide to contract specialist companies to carry out sampling. In this case the PSCO should attend the ship during the sampling procedure to ensure the liaison and arrangements mentioned above are in place.

If a specialist company is not used, the port State competent authority should provide appropriate training to the PSCO in the available sampling methods and procedures and ensure that agreed procedures are followed.

The following general terms should be observed:

- the PSCO should choose a number of sample points preferably covering all the representative areas of the hull, but it is desirable to have at least eight (8) sample points equally spaced down and over the length of the hull, if possible divided over PS and SB (keeping in mind that different parts of the hull may be treated with different anti-fouling systems);
- triplicate specimens of paint at each sampling point should be taken in close proximity to each other on the hull (e.g., within 10 cm of each other);
- contamination of the samples should be avoided, which normally includes the wearing of non-sterilized non-powdered disposable gloves of suitable impervious material – e.g., nitrile rubber;
- the samples should be collected and stored in an inert container (e.g., containers should not consist of materials containing organotins and cybutryne or have the capacity to absorb organotins and cybutryne);
- samples should be taken from an area where the surface of the anti-fouling system is intact, clean and free of fouling;
- loose paint chips coming from detached, peeled or blistered hull areas should not be used for sampling;
- samples should not be taken from a heated or area where the paint is otherwise softened (e.g., heavy fuel tanks); and
- the underlying layers (primers, sealers, TBT containing AFS) should not be sampled if there is no clear evidence of exposure of extended areas.
- Ships bearing an anti-fouling system that does not contain cybutryne in the external coating layer are not required to be controlled under annex 1 of the Convention. Such ships carrying an IAFS Certificate indicating the situation described in paragraph 2.1.6.4 of these Guidelines should be deemed compliant with the Convention except if there is a doubt on the validity of the IAFS Certificate.

## 2 Validity of the sampling

In order to safeguard the validity of the sampling as evidence of non-compliance, the following should be considered:

- only samples taken directly from the hull and free of possible contamination should be used;
- all samples should be stored in containers, marked and annotated on the record sheet. This record sheet should be submitted to the Administration;
- the receipts identifying the persons having custody and receiving transfer of the samples should be filled in and accompany the samples to reflect the transfer chain of the samples;
- the PSCO should verify the validity of the instrument's calibration validity date (according to the manufacturer instruction);
- in cases when a contracted specialist company is used for carrying out sampling, the PSCO should accompany its representative to verify sampling; and
- photographs of the hull, sample areas and sampling process could serve as additional proof.

It is also the case that sampling companies and/or procedures can be certified.

### **3 Health and safety when sampling**

Any obligation to take a sample should be subject to practical feasibility or any constraints relating to the safety of persons, the ship or the port.

The PSCO is advised to ensure their safety taking the following points into account:

- general requirements enforced by the terminal or port authority and national health, safety and environmental policy;
- condition of the ship (ballast condition, ship's operations, mooring, anchorage, etc.);
- surroundings (position of ship, traffic, ships movement, quay operations, barges or other floating vessels alongside);
- safety measures for the use of access equipment (platforms, cherry picker, staging, ladders, railings, climbing harness, etc.), e.g., ISO 18001;
- weather (sea state, wind, rain, temperature, etc.); and
- precautions to avoid falling into the water between the quay and the ship. If in doubt, a lifejacket and if possible a safety line, should be worn when sampling.

Any adverse situation encountered during sampling that could endanger the safety of personnel, shall be reported to the safety coordinator.

Care should be taken to avoid contact of the removed paint with the skin and the eyes, and no particles should be swallowed or come into contact with foodstuffs. Eating or drinking during sampling is prohibited and hands should be cleaned afterwards. Persons carrying out sampling should be aware that the AFS and solvents or other materials used for sampling may be harmful and appropriate precautions should be taken. Personal protection should be considered by using long sleeve solvent-resistant gloves, dust mask, safety glasses, etc.

Standard (and specific, if applicable) laboratory safety procedures should be followed at all times when undertaking the sampling procedures and subsequent analysis.

#### **4 Conducting analyses**

The Guidelines for brief sampling of anti-fouling systems on ships envisage a two-stage analysis of samples for organotin analysis for both methods presented in the appendix to the Guidelines. The first stage is a basic test, which can be carried out on site as in the case of Method 2. The second stage is carried out when the first stage results are positive. It is noted that in the IMO Guidelines, these stages are referred to as Steps 1 and 2 as in the case of Method 1. It is to the discretion of the port State competent authorities to choose which analysis methods are used.

The method for cybutryne determination is based on a one step analysis.

The following points are presented for port State consideration:

- approval procedure for the recognition of laboratories meeting ISO 17025 standards or other appropriate facilities should be set up by the port State competent authorities. These procedures should define the recognition criteria. Exchange of information between port States on these procedures, criteria and laboratories/facilities would be beneficial, i.e. for the purposes of exchange of best practices and possible cross-border recognition and provision of services;
- the company that undertakes the analysis and/or samples should comply with national regulations and be independent from paint manufacturers;
- the PSCO carrying out the AFS inspection of a ship should verify the validity of the ISO 17025 certificate and/or the recognition of the laboratory;
- if more time is needed for analysis than available considering the ship's scheduled time of departure, the PSCO shall inform the ship and report the situation to the port State competent authority. However, the time needed for analysis does not warrant undue delay of the ship; and
- PSCOs should ensure completion of the record sheets for the sampling procedure as proof of analysis. In cases when the laboratory procedures prescribe presentation of the analyses' results in a different format, this technical report could be added to the record sheets.

#### **5 The first-stage analysis for organotin**

The first-stage analysis serves to detect the total amount of tin in the AFS applied.

It is to the discretion of the port State competent authority to choose the first-stage analysis methodology. However, the use of a portable X-ray fluorescence analyser (mentioned under Method 2) or any other scientifically justified method allowing the conduction of first-stage analyses on site could be considered best practice.

The port State competent authority has to decide whether the first-stage analysis should be carried out by PSCOs or by contracted companies.

The port State competent authority could provide PSCOs with this equipment (e.g., portable X-ray fluorescence analyser) and provide the appropriate training.

#### **6 The second-stage analysis for organotin**

The second-stage (final) analysis is used to verify whether or not the AFS system complies with the Convention requirements, i.e. whether organotin compounds are present in the AFS at a level which would act as a biocide.

The port State could consider implementing only a second-stage analysis.

It is to the discretion of the Authority to choose the second-stage analysis methodology. In this respect it is hereby noted that the second-stage analysis methodology for sampling Method 2 provided in the Guidelines is only tentative and "should be thoroughly reviewed by experts based on scientific evidence" (section 5.1 of Method 2).

## **7 One stage analysis for cybutryne**

For cybutryne a one stage analysis is described in both method 1 and method 2 of the brief sampling guidelines. The specimens are to be analyzed in a GC-MS analysis. The procedure is the same for both methods.

## **8. One stage analysis for cybutryne and organotin**

For cybutryne and organotin a one stage analysis is described in both method 1 and method 2 of the brief sampling guidelines. The specimens are to be analyzed in a GC-MS analysis.

## **7-9 Conclusions on compliance**

The Authority should only make conclusions on compliance based on the second-stage analysis of the sample (organotin). In case the results indicate non-compliance at that stage, there are clear grounds to take further steps.

For cybutryne the authority could make conclusions on compliance based on the one stage analysis.

If considered necessary, more thorough sampling can be also carried out in addition or instead of brief sampling.

Sampling results should be communicated as soon as possible to the vessel (as part of the inspection report) and in the case of non-compliance also to the flag State and Recognized Organization acting on behalf of the flag State if relevant.

Authorities should, in accordance with section 5.2 of the Guidelines for brief sampling of anti-fouling systems on ships, develop and adopt procedures to be followed for those cases where compliance with acceptable limits or lack thereof, is unclear, considering additional sampling or other methodologies for sampling.

**FORM S/1**

REPORT OF INSPECTION of a ship's anti-fouling system (AFS)

**SHIP PARTICULARS**

1. Name of ship: \_\_\_\_\_ 2. IMO number: \_\_\_\_\_  
3. Type of ship: \_\_\_\_\_ 4. Call sign: \_\_\_\_\_  
5. Flag of ship: \_\_\_\_\_ 6. Gross tonnage: \_\_\_\_\_  
7. Date keel laid / major conversion commenced: \_\_\_\_\_

**INSPECTION PARTICULARS**

8. Date & time: \_\_\_\_\_  
9. Name of facility: \_\_\_\_\_  
(dry-dock, quay, location) \_\_\_\_\_  
Place & country: \_\_\_\_\_  
10. Areas inspected  Ship's logbook  Certificates  Ship's hull  
11. Relevant certificate(s)  
(a) title (b) issuing authority (c) dates of issue  
1. IAFS Cert. \_\_\_\_\_  
2. Record of AFS \_\_\_\_\_  
3. Declaration of AFS \_\_\_\_\_  
4. \_\_\_\_\_  
12. Dry-dock period AFS applied: \_\_\_\_\_  
13. Name of facility AFS applied: \_\_\_\_\_  
14. Place & country AFS applied: \_\_\_\_\_  
15. AFS samples taken  No  Yes Nature of sampling:  Brief  Extent  
16. Reason for sampling of AFS: \_\_\_\_\_  
17. Record sheet attached : \_\_\_\_\_  
(country-code / IMO number / dd-mm-yy)  
18. Copy to:  PSCO  Flag State  Recognized Organization  
Head office  Master  Other: \_\_\_\_\_

**PORT STATE PARTICULARS**

Reporting authority:

District office

Address:

---

---

Telephone/Fax/ Mobile:

---

E-mail:

---

Name:

*(duly authorized  
inspector of reporting  
authority)*

---

Date:

---

Signature:

---



**FORM S/2**

**Record sheet for the sampling procedure for compliance with the Convention in terms of the presence of organotin and/or cybutryne acting as a biocide in anti-fouling systems on ship hulls**

RECORD NUMBER	
---------------	--

(country-code / IMO number / dd-mm-yy)

Name of ship \_\_\_\_\_ IMO number: \_\_\_\_\_

**SAMPLING PARTICULARS**

<p>1. <b>Date &amp; time initiated:</b></p> <p>3. <b>Name of paint manufacturer:</b></p> <p>4. <b>AFS product name &amp; colour:</b></p> <p>5. <b>Reason for Sampling:</b>      for    <input type="checkbox"/> <b>Port State Control</b>      <input type="checkbox"/> <b>Survey Certification</b>      &amp;    <input type="checkbox"/> <b>Other flag compliance inspection</b>      <b>State</b></p> <p>6. <b>Sampling Method</b> _____</p> <p>7. <b>Hull areas sampled:</b>    <input type="checkbox"/> <b>Port Side</b>      <input type="checkbox"/> <b>Starboard Side</b>      <input type="checkbox"/> <b>Bottom</b></p> <p><b>Number of sampling points:</b> _____</p> <p>8. <b>Back-up samples' storage location:</b> <i>(e.g., Port State inspection office)</i></p> <p>9. <b>Photos taken of the sample points</b></p> <p>10. <b>Paint samples (wet)</b></p> <p>11. <b>Case A - Analysis of organotin only</b></p> <p style="padding-left: 40px;">First-stage analysis for organotin    Comments: _____</p> <p style="padding-left: 40px;">Second-stage analysis for organotin    Comments: _____</p> <p>12. <b>Case B - Analysis of cybutryne only</b></p> <p style="padding-left: 40px;">One stage analysis for cybutryne</p> <p>13. <b>Case C - Simplified approach to detect organotin and cybutryne</b></p> <p style="padding-left: 40px;">One-stage analysis for organotin and cybutryne</p>	<p>2. <b>Date &amp; time completed</b></p> <p>Comments: _____</p> <p>Comments: _____</p> <p>Comments: _____</p> <p>Comments: _____</p> <p>Comments: _____</p> <p>Comments: _____</p> <p>Comments: _____</p> <p>Comments: _____</p> <p>Comments: _____</p> <p>Comments: _____</p> <p>Comments: _____</p>
---	---

~~13-14.~~ **14.** **Comments concerning sampling procedure**

<b>14-15</b> <b>Sampling company</b>	<b>Name</b>
	<b>Date</b>
	<b>Signature</b>

**PORT STATE PARTICULARS**

**Reporting authority:**

**District office:**

**Address:**

---

---

**Telephone/Fax/**

**Mobile:**

---

**E-mail:**

---

**Name:**

*(duly authorized  
inspector of reporting  
authority)*

---

**Date:**

---

**Signature:**

---

**FORM S/3**

RECORD NUMBER	
---------------	--

Name of ship \_\_\_\_\_ IMO number: \_\_\_\_\_

**METHOD 1 ANALYSIS**

**Case A - Analysis of organotin only**

1.	Instrument I.D.:		Calibration	Expire Date:	
2.	Specimens "A" results			total number of specimens "A" analysed:	
3.	No.	Sample location <i>(Frame &amp; Distance from boot topping)</i>	mg Sn/ kg	No.	Sample location <i>(Frame &amp; distance from boot topping)</i> mg Sn/ kg
	1			9	
	2			10	
	3			11	
	4			12	
	5			13	
	6			14	
	7			15	
	8			16	
4.	<b>Results</b> Number of specimens exceeding 2,500 mg/kg: <input type="checkbox"/> Step 2 required  1 or more specimens exceeding 3,000 mg/kg <input type="checkbox"/> Yes <input type="checkbox"/> No <input type="checkbox"/> Compliance, NO further analysis				
5.	<b>Additional comments concerning analysis of results from Specimens "A"</b>				
6.	<b>Company</b>			<b>Name:</b>  <b>Date:</b>  <b>Signature:</b>	

7.	Instrument I.D.:		Calibration Expire Date:	
8.	Specimens "B" results		total number of specimens "B" analysed:	
9.	No.	organotin (mg Sn/ kg) as Sn	No.	organotin (mg Sn/ kg) as Sn
	1		5	
	2		6	
	3		7	
	4		8	
10.	Results			
	Number of specimens exceeding 2,500 mg/kg:			<input type="checkbox"/> <b>Non-compliance assumed</b>
	1 or more specimens exceeding 3,000 mg/kg			<input type="checkbox"/> Compliance, assumed
	<input type="checkbox"/> Yes <input type="checkbox"/> No			
11.	Additional comments concerning analysis of results from Specimens "B"			
12.	Company		Name:	
			Date:	
			Signature:	

### Case B - Analysis of cybutryne only

Gas chromatography/mass spectrophotometry (GC/MS) analysis

1.	Instrument I.D.:		Calibration Expire Date:	
2.	Specimens "C" results			
	total number of specimens "C" analysed by GC-MS:			
	Average concentration of cybutryne (mg of cybutryne per kg of dry paint):			
4.	Conclusions			
	The average concentration of cybutryne exceeds the threshold of 1,250 mg of cybutryne per kg of dry paint			<input type="checkbox"/> yes <input type="checkbox"/> No. Compliance assumed.
5.	Additional comments concerning analysis of results from Specimens "C"			
6.	Company		Name:	
			Date:	
			Signature:	

### Case C - Simplified approach to detect organotin and cybutryne

Gas chromatography/mass spectrophotometry (GC/MS) analysis

1.	Instrument I.D.:		Calibration Expire Date:	
2.	Specimens "C" results			
	total number of specimens "C" analysed by GC-MS:			
	Average concentration of organotin (mg Sn/kg)			

	of dry paint)	
	Average concentration of cybutryne (mg of cybutryne per kg of dry paint):	
<b>4.</b>	<b>Conclusions</b>	
	The average concentration of organotin exceeds the threshold of 3 000 mg Sn per kg of dry paint	<input type="checkbox"/> yes <input type="checkbox"/> No. Compliance assumed.
	The average concentration of cybutryne exceeds the threshold of 1,250 mg of cybutryne per kg of dry paint	<input type="checkbox"/> yes <input type="checkbox"/> No. Compliance assumed.
<b>5.</b>	<b>Additional comments concerning analysis of results from Specimens "C"</b>	
<b>6.</b>	<b>Company</b>	<b>Name:</b>  <b>Date:</b>  <b>Signature:</b>

**FORM S/4**

RECORD NUMBER	
---------------	--

Name of ship \_\_\_\_\_ IMO number: \_\_\_\_\_

**METHOD 2**

**Case A - Analysis of organotin only**

**FIRST-STAGE ANALYSIS FOR ORGANOTIN ANALYSIS**

<b>1.</b>	Instrument I.D.:	Calibration Expire Date:
-----------	------------------	--------------------------

<b>2.</b>	Sample location (Frame & distance from boot topping)	Specimen I.D.	Sample Disc	Content of Tin (mg/ kg)	max	min	Average
<b>A</b>		A1	<input type="checkbox"/> abrasive				
		A2	<input type="checkbox"/> metal				
		A3	<input type="checkbox"/> others				Average
		A4	<input type="checkbox"/> abrasive				
		A5	<input type="checkbox"/> metal				mg/kg
		A6	<input type="checkbox"/> others				<input type="checkbox"/> >2,500 mg/kg
		A7	<input type="checkbox"/> abrasive				<input type="checkbox"/> >3,000 mg/kg
		A8	<input type="checkbox"/> metal				
		A9	<input type="checkbox"/> others				
<b>B</b>		B1	<input type="checkbox"/> abrasive				
		B2	<input type="checkbox"/> metal				
		B3	<input type="checkbox"/> others				Average
		B4	<input type="checkbox"/> abrasive				
		B5	<input type="checkbox"/> metal				mg/kg
		B6	<input type="checkbox"/> others				<input type="checkbox"/> >2,500 mg/kg
		B7	<input type="checkbox"/> abrasive				<input type="checkbox"/> >3,000 mg/kg
		B8	<input type="checkbox"/> metal				
		B9	<input type="checkbox"/> others				
<b>C</b>		C1	<input type="checkbox"/> abrasive				
		C2	<input type="checkbox"/> metal				
		C3	<input type="checkbox"/> others				Average
		C4	<input type="checkbox"/> abrasive				
		C5	<input type="checkbox"/> metal				mg/kg
		C6	<input type="checkbox"/> others				<input type="checkbox"/> >2,500 mg/kg
		C7	<input type="checkbox"/> abrasive				<input type="checkbox"/> >3,000 mg/kg
		C8	<input type="checkbox"/> metal				
		C9	<input type="checkbox"/> others				
<b>D</b>		D1	<input type="checkbox"/> abrasive				
		D2	<input type="checkbox"/> metal				
		D3	<input type="checkbox"/> others				Average
		D4	<input type="checkbox"/> abrasive				
		D5	<input type="checkbox"/> metal				mg/kg
		D6	<input type="checkbox"/> others				<input type="checkbox"/> >2,500 mg/kg

	D7	<input type="checkbox"/> abrasive			<input type="checkbox"/> >3,000 mg/kg
	D8	<input type="checkbox"/> metal			
	D9	<input type="checkbox"/> others			
3.	<b>Results First-Stage Analysis</b>				
	<input type="checkbox"/> samples out of _____ are above 2,500 mg/kg <input type="checkbox"/> sample(s) _____ is (are) above 3,000 mg/kg			<input type="checkbox"/> Compliant <input type="checkbox"/> <b><u>Second-stage required</u></b>	
4.	<b>Comments</b>				
5.	<b>Company</b>		Name Date Signature		

**FORM S/5**

RECORD NUMBER	
---------------	--

Name of ship \_\_\_\_\_ IMO number: \_\_\_\_\_

**METHOD 2 SECOND-STAGE ANALYSIS FOR ORGANOTIN ANALYSIS**

1.	<b>Instrument I.D.:</b>	<b>Calibration Expire Date:</b>
----	-------------------------	---------------------------------

2.	Specimen used (Specimen I.D.)	Content of Tin First-Stage (XRF Analysis) (mg Sn/kg)	Content of Tin Second-Stage (as organotin) (mg Sn/kg)	Compliance
A				<input type="checkbox"/> >2,500 mg/kg <input type="checkbox"/> >3,000 mg/kg
B				<input type="checkbox"/> >2,500 mg/kg <input type="checkbox"/> >3,000 mg/kg
C				<input type="checkbox"/> >2,500 mg/kg <input type="checkbox"/> >3,000 mg/kg
D				<input type="checkbox"/> >2,500 mg/kg <input type="checkbox"/> >3,000 mg/kg
3.	<b>Results Second-Stage Analysis</b>			
	<input type="checkbox"/> samples out of _____ are above 2,500 mg/kg (dry paint) <input type="checkbox"/> sample(s) _____ is (are) above 3,000 mg/kg (dry paint)			<input type="checkbox"/> Compliant <input type="checkbox"/> <b><u>NOT compliant</u></b>
4.	<b>Comments</b>			

5.	Company	Name
		Date
		Signature

**Case B - Analysis of cybutryne only**  
**Gas chromatography/mass spectrophotometry (GC/MS) analysis for cybutryne determination**

1.	Instrument I.D.:	Calibration Expire Date:
2.	<b>Results of GC-MS analysis</b>	
	Average concentration (mg of cybutryne per kg of dry paint)	<input type="checkbox"/> Compliant <input type="checkbox"/> <b>NOT compliant</b>
3.	Comments	
4.	Company	Name
		Date

**Case C - Simplified approach to detect organotin and cybutryne**  
**Gas chromatography/mass spectrophotometry (GC/MS) analysis for cybutryne and organotin determination**

1.	Instrument I.D.:	Calibration Expire Date:
2.	<b>Results of GC-MS analysis</b>	
	Average concentration of organotin (mg Sn/kg)	<input type="checkbox"/> Compliant <input type="checkbox"/> <b>NOT compliant</b>
	Average concentration of cybutryne (mg of cybutryne per kg of dry paint)	<input type="checkbox"/> Compliant
		<input type="checkbox"/> <b>NOT compliant</b>
3.	Comments	
4.	Company	Name
		Date

**PORT STATE PARTICULARS**

Reporting authority:

District office

Address:

---



---



Telephone/Fax/ Mobile: \_\_\_\_\_

E-mail: \_\_\_\_\_

Name:  
*(duly authorized  
inspector of reporting  
authority)* \_\_\_\_\_

Date: \_\_\_\_\_ Signature: \_\_\_\_\_

**AFS INSPECTION PROCESS**

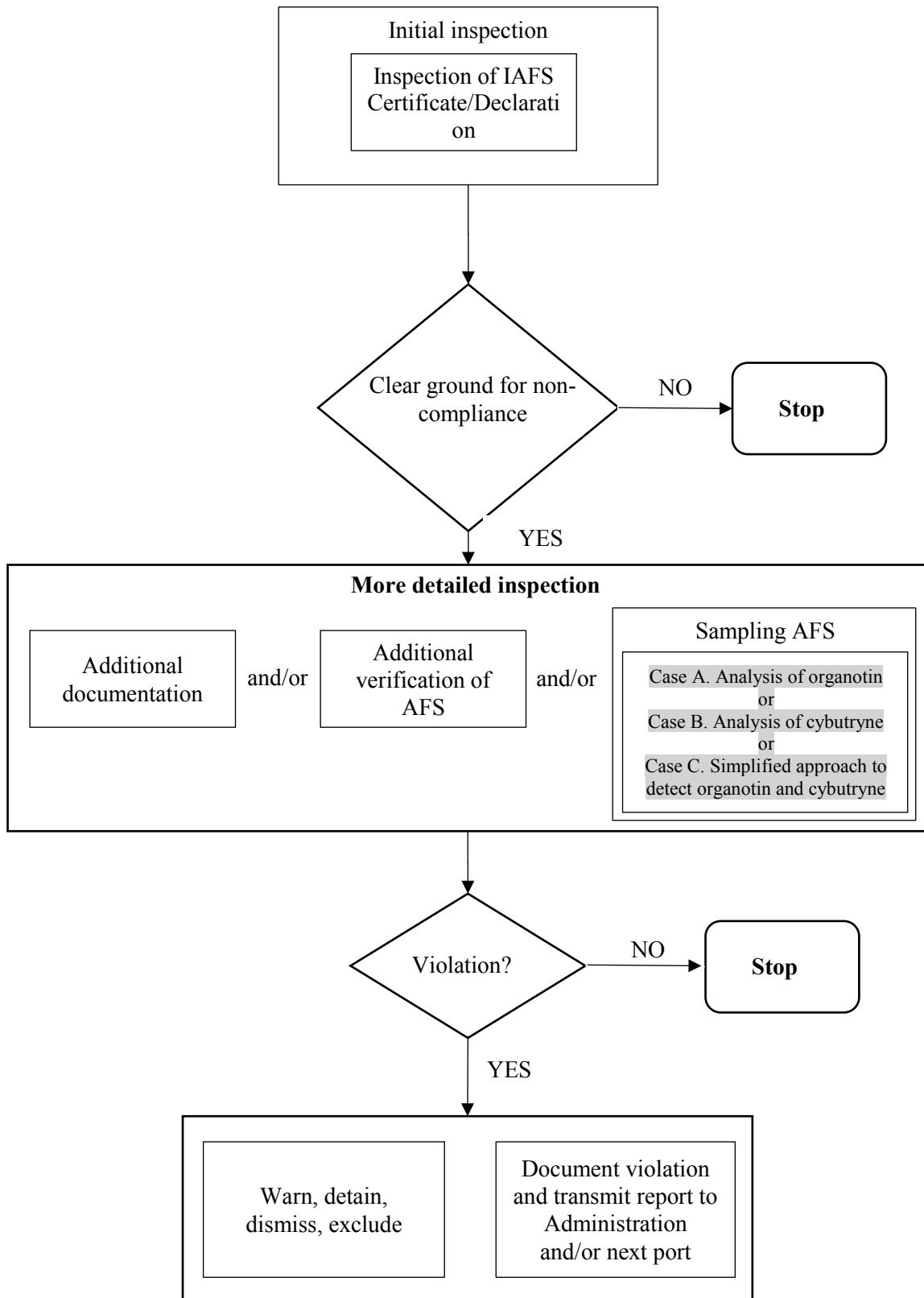

## **Annex 3 – Suggested text amendments to the Guidelines for survey and certification of anti-fouling systems on ships**

### **2010 GUIDELINES FOR SURVEY AND CERTIFICATION OF ANTI-FOULING SYSTEMS ON SHIPS**

#### **1 General**

1.1 Article 10 of the International Convention on the Control of Harmful Anti-fouling Systems on Ships, 2001, hereinafter referred to as "the Convention", prescribes that ships shall be surveyed and certified in accordance with the regulations of annex 4 of the Convention. The purpose of this document is to provide the Guidelines for Surveys and Certification of Anti-fouling Systems on Ships referred to in regulation 1(4)(a) of annex 4, hereinafter referred to as the "Guidelines", that will assist the Administrations and recognized organizations, in the uniform application of the provisions of the Convention and assist companies, shipbuilders, manufacturers of anti-fouling systems, as well as other interested parties to understand the process of the surveys and issuance and endorsement of the certificates.

1.2 These Guidelines provide the procedures for survey to ensure that a ship's anti-fouling system complies with the Convention, and those necessary for issuance and endorsement of an International Anti-fouling System Certificate. A guidance for compliant anti-fouling systems is given in the Appendix I to this annex.

1.3 These Guidelines apply to surveys of ships of 400 gross tonnage and above engaged in international voyages, excluding fixed or floating platforms, floating storage units (FSUs), and floating production storage and off-loading units (FPSOs), as specified in regulation 1(1) of annex 4 to the Convention.

1.4 The sole purpose of the survey activities described in these Guidelines is to verify compliance with the provisions of the Convention. Consequently, such surveys do not relate to any aspect not regulated by the Convention even if such aspects relate to the performance of an anti-fouling system on the hull of a ship, including the quality of workmanship during the application process.

1.5 In the event that a new survey method is developed, or in the event that the use of a certain anti-fouling system is prohibited and/or restricted, or in the light of experience gained, these Guidelines may need to be revised in the future.

#### **2 Definitions**

For the purposes of these guidelines:

2.1 "Administration" means the Government of the State under whose authority the ship is operating. With respect to a ship entitled to fly a flag of a State, the Administration is the Government of that State. With respect to fixed or floating platforms engaged in exploration and exploitation of the sea-bed and subsoil thereof adjacent to the coast over which the coastal State exercises sovereign rights for the purposes of exploration and exploitation of their natural resources, the Administration is the Government of the coastal State concerned.

2.2 "Anti-fouling system" means a coating, paint, surface treatment, surface, or device that is used on a ship to control or prevent attachment of unwanted organisms.

2.3 "Company" means the owner of the ship or any other organization or person such as the manager or the bareboat charterer, who has assumed the responsibility for the operation of the ship from the owner of the ship and who, on assuming such responsibility, has agreed to take over all duties and responsibilities imposed by the International Safety Management (ISM) Code.

2.4 "Gross tonnage" means the gross tonnage calculated in accordance with the tonnage measurement regulations contained in annex 1 to the International Convention on Tonnage Measurement of Ships, 1969, or any successor Convention.

2.5 "International voyage" means a voyage by a ship entitled to fly the flag of one State to or from a port, shipyard, or offshore terminal under the jurisdiction of another State.

2.6 "Length" means the length as defined in the International Convention on Load Lines, 1966, as modified by the Protocol of 1988 relating thereto, or any successor Convention.

2.7 "Ship" means a vessel of any type whatsoever operating in the marine environment and includes hydrofoil boats, air-cushion vehicles, submersibles, floating craft, fixed or floating platforms, floating storage units (FSUs) and floating production storage and off-loading units (FPSOs).

### **3 General requirements for surveys**

3.1 An initial survey covering at least the scope as in paragraph 1 of appendix II of these Guidelines should be held before the ship is put into service and the International Anti-fouling System Certificate required under regulation 2 or 3 of annex 4 to the Convention is issued for the first time.

3.2 A survey should be carried out whenever an anti-fouling system is changed or replaced. Such surveys should cover the scope as in paragraph 2 of appendix II to these Guidelines.

3.3 A major conversion affecting the anti-fouling system of a ship may be considered as a newbuilding as determined by the Administration.

3.4 Repairs generally do not require a survey. However, repairs affecting approximately twenty-five (25) per cent or more of the anti-fouling system, should be considered as a change or replacement of the anti-fouling system.

3.5 A non-compliant anti-fouling system controlled under annex 1 of the Convention, that undergoes repair must be repaired, or replaced with a compliant anti-fouling system.

### **4 Request for survey**

4.1 Prior to any survey, a request for survey should be submitted by the Company to the Administration, or to a recognized organization along with the ship's data required in the International Anti-fouling System Certificate as listed:

- .1 Name of ship
- .2 Distinctive number or letters
- .3 Port of registry

- .4 Gross tonnage
- .5 IMO number.

4.2 A request for survey should be supplemented by a declaration and supporting information from the anti-fouling system manufacturer, confirming that the anti-fouling system applied, or intended to be applied to the ship is in compliance with the requirements of the Convention (with an identification of the version of the Convention referred to). Such declaration should provide the following information contained in the Record of Anti-fouling System, as can be found in appendix 1 to annex 4 to the Convention:

- .1 Type of anti-fouling system<sup>9</sup>
- .2 Name of anti-fouling system manufacturer
- .3 Name and colour of anti-fouling system
- .4 Active ingredient(s) and their Chemical Abstract Service Registry Number (CAS number(s)).

Information required by the surveyor regarding compliance of product with the Convention should be found in a declaration from the anti-fouling system manufacturer which may be provided on the anti-fouling system container and/or on supportive documentation (such as Material Safety Data Sheets (MSDSs), or similar). A link between the supportive documentation and the relevant container should exist.

## **5 Conduct of surveys**

### **5.1 Initial Surveys** (Surveys in accordance with regulation 1(1)(a) of annex 4 to the Convention)

- .1 The initial survey should verify that all applicable requirements of the Convention are complied with.
- .2 As part of the survey, it should be verified that the anti-fouling system specified by the documentation submitted with the request for survey complies with the Convention. The survey should include verification that the anti-fouling system applied is identical to the system specified in the request for survey.
- .3 Taking into account experience gained and the prevailing circumstances, the initial survey should include the tasks as listed in paragraph 1 of appendix II to these Guidelines.
- .4 The verification tasks set out in paragraph 5.1.2 should be conducted at any time, either before, during, or after the anti-fouling system has been applied to the ship, as deemed necessary to verify compliance. No checks or tests must affect the integrity, structure or operation of the anti-fouling system.

### **5.2 Surveys when the anti-fouling systems are changed or replaced** (Surveys in accordance with regulation 1(1)(b) of Annex 4 to the Convention)

---

<sup>9</sup> Examples of suitable wording could be: *Organotin-free self polishing type, Organotin-free ablative type, Organotin-free Conventional, Biocide-free silicon type paint, others. In the case of an anti-fouling system containing no active ingredients, the words "biocide-free" should be used.*

- .1 If the existing anti-fouling system is confirmed by an International Anti-fouling System Certificate not to be controlled under annex 1 of the Convention, the provisions described in paragraph 5.1 and 5.2 apply.
- .2 If the existing anti-fouling system is declared not to be controlled under annex 1 of the Convention, without being documented by an International Anti-fouling System Certificate, a verification should be carried out to confirm that the anti-fouling system complies with the requirements of the Convention. This verification may be based on sampling and/or testing and/or reliable documentation, as deemed necessary based on experience gained and the existing circumstances. Documentation for verification could, e.g., be MSDSs, or similar, a declaration of compliance from the anti-fouling system manufacturer, invoices from the shipyard and/or the anti-fouling system manufacturer. To verify the new anti-fouling system, the provisions described in paragraph 5.1 apply.
- .3 If the existing anti-fouling system has been removed, the removal should be verified in addition to the provisions described in paragraph 5.1.
- .4 If a sealer coat has been applied, a verification should be carried out to confirm that the name, type and colour of the sealer coat applied to the ship match those specified in the request for survey, and that the existing anti-fouling system has been covered with that sealer coat. Additionally the provisions described in paragraph 5.1 apply.
- .5 An existing anti-fouling system controlled under annex 1 of the Convention, containing organotin:
  - .1 ~~applied on/after 1 January 2003 or a later date if specified by the Administration, should be removed according to subparagraph 5.2.3;~~
  - .2 applied before 1 January 2003 or a later date if specified by the Administration, ~~should be~~ must have been removed or covered by a sealer coat according to subparagraph 5.2.4, not later than 60 months after its application and latest on 1 January 2008.
- .6 An existing anti-fouling system controlled under annex 1 of the Convention, containing cybutryne in the external coating layer:
  - .2 applied before date 1 January 2023, should be removed or covered by a sealer coat according to subparagraph 5.2.4.
- .6 .7 The survey should include the tasks as listed in paragraph 2 of Appendix II to these Guidelines.

### 5.3 Surveys of existing ships requesting only an International Anti-fouling System Certificate

- .1 If the existing anti-fouling system is declared not to be controlled under annex 1 of the Convention, a verification should be carried out to confirm that the anti-fouling system complies with the requirements of the Convention. This verification may be based on sampling and/or testing and/or reliable

documentation, as deemed necessary based on experience gained and the existing circumstances. Such documentation could be MSDSs or similar, a declaration of compliance from the anti-fouling system manufacturer, invoices from the shipyard and/or the anti-fouling system manufacturer. If this information raises no reasonable doubt that the system applied is compliant with annex 1 of the Convention, the International Anti-fouling System Certificate may be issued on this basis.

## **6 Issuing or endorsing the International Anti-fouling System Certificate**

6.1 The International Anti-fouling System Certificate along with the Record of Anti-fouling Systems should be:

- .1 issued upon satisfactory completion of the initial survey;
- .2 issued upon acceptance of another Party's International Anti-fouling System Certificate; or
- .3 endorsed upon satisfactory completion of a survey for change or replacement of an anti-fouling system.

\* \* \*

## APPENDIX I to Annex 3

### *Guidance for compliant anti-fouling systems*

1. For the purpose of compliance with annex 1 of the Convention, small quantities of organotin compounds acting as a chemical catalyst (such as mono- and di- substituted organotin compounds) are allowed, provided that they are present at a level which does not provide a biocidal effect to the coating. On a practical level, when used as a catalyst, an organotin compound should not be present above 2,500 mg total tin per kilogram of dry paint.

2. For the purpose of compliance with annex 1 of the Convention in respect to cybutryne, it could be expected that the distribution of the remaining anti-fouling paint in the hull surface is not uniform. Due to hull design and consequent action of the sea water during the service life of the paint, the paint may not have uniformly eroded, some parts in the hull may still have some paint, other parts may not have any paint left. Therefore, the brief samples taken from the hull surface should be representative of the anti-fouling system applied. Average values of cybutryne should not be present above 1,000 mg of cybutryne per kilogram of dry paint. Below this level any remaining cybutryne is expected not to create a negative impact to the marine environment.

\* \* \*



## APENDIX II to Annex 3

Guidance for surveys under the International Convention on the Control of Harmful Anti-fouling Systems on Ships (AFS 2001)

- (FI) 1 Initial survey (AFS 2001, annex 4, regulation 1(1)(a))
- (FI) 1.1 confirming that a Declaration and supporting information from the anti-fouling system manufacturer, specifying that the anti-fouling system and, where applicable, the sealer coat intended to be applied to the ship are in compliance with the requirements of the Convention, is provided (AFS 2001);
- (FI) 1.2 verifying that the relevant containers of the anti-fouling system show same data as the supporting information (AFS 2001);
- (FI) 1.3 confirming that the existing anti-fouling system, if controlled under annex 1 of the Convention, has been removed or that a sealer coat has been applied (AFS 2001);
- (FI) 1.4 verifying, where applicable, that the relevant containers of the sealer coat applied show same data as the supporting information (AFS 2001);
- (FI) 1.5 where supporting information from the anti-fouling system manufacturer is not available or does not provide sufficient information, sampling or testing or other checks conducted on site, of the anti-fouling system;
- (FI) 1.6 for ship of 24 m or more in length but less than 400 GT and engaged in international voyages, confirming that the owner or owner's authorized agent has completed a Declaration on Anti-fouling System (AFS 2001).
- (FR) 2 Surveys when anti-fouling systems are changed or replaced (AFS 2001, annex 4, regulation 1(1)(b))
- (FR) 2.1 confirming that a Declaration and supporting information from the anti-fouling system manufacturer, specifying that the anti-fouling system and, where applicable, the sealer coat intended to be applied to the ship are in compliance with the requirements of the Convention, is provided (AFS 2001);
- (FR) 2.2 verifying that the relevant containers of the anti-fouling system show same data as the supporting information (AFS 2001);
- (FR) 2.3 confirming that the existing anti-fouling system, if controlled under annex 1 of the Convention, has been removed or that a sealer coat has been applied (AFS 2001);
- (FR) 2.4 verifying, where applicable, that the relevant containers of the sealer coat applied show same data as the supporting information (AFS 2001);
- (FR) 2.5 for ship of 24 m or more in length but less than 400 GT, confirming that the owner or owner's authorized agent has completed a Declaration on Anti-fouling System (AFS 2001);
- (FR) 2.6 endorsement of the Record of Anti-fouling Systems.

\* \* \*