



Council of the
European Union

Brussels, 12 December 2017
(OR. en)

**Interinstitutional File:
2016/0084 (COD)**

14010/1/17
REV 1

LIMITE

ENT 221
MI 777
AGRILEG 210
ENV 892
CHIMIE 91
IND 287
CODEC 1742

NOTE

From:	Presidency/General Secretariat of the Council
To:	Permanent Representatives Committee
No. prev. doc.:	14452/17 ENT 239 MI 847 AGRILEG 226 ENV 941 CHIMIE 97 IND 319 CODEC 1842
No. Cion doc.:	7396/16 ENT 56 MI 176 AGRILEG 32 ENV 185 CHIMIE 16 IND 58 CODEC 347 IA 11 + ADD 1
Subject:	Proposal for a REGULATION OF THE EUROPEAN PARLIAMENT AND OF THE COUNCIL laying down rules on the making available on the market of CE marked fertilising products and amending Regulations (EC) No 1069/2009 and (EC) No 1107/2009 - Preparation of the trilogue

I. INTRODUCTION

1. On 17 March 2016, the Commission transmitted the above-mentioned proposal for a Regulation to the European Parliament and to the Council.

The Regulation has as its objective to incorporate all kinds of fertilising products, including organic and inorganic fertilisers into a unified framework for placing such products on the EU market. However, those fertilising products which do not fulfil EU rules (esp. on contaminants or nutrient content) can still be placed on the national markets without the CE marking and will therefore come under mutual recognition rules. In making this political distinction between "EU fertilisers" and "non-harmonised fertilisers" the proposal follows the idea of optional harmonisation. The obligations of economic operators, the provisions on notified bodies and on market surveillance follow the logic of the New Legislative Framework (NLF). The proposal defines Product Function Categories and Component Material Categories in the Annexes and in particular fixes limit values on contaminants and nutrients for them. There is also a degree of delegation of powers to the Commission for the purpose of amending annexes to technical progress.

2. The European Economic and Social Committee issued its opinion on 14 July 2016.
3. The Committee of the Regions did not issue an opinion on this proposal.
4. The EP Committee on the Internal Market, Consumer Protection voted its report on 25 July 2017. This vote was confirmed (with certain modifications) at the European Parliament Plenary Meeting of 25 October 2017.

II. WORK CONDUCTED WITHIN THE COUNCIL

5. The examination of the proposal by the Working Party on Technical Harmonisation (Fertilising Products) started in April 2016. 22 meetings of this Working Party were held on this proposal during the Dutch, Slovak, Maltese and Estonian Presidencies. The discussion concentrated on the provisions concerning delegated acts as well as on all of the annexes (Product function categories, Component Material Categories, Labelling provisions and Conformity Assessment Modules)
6. The impact assessment accompanying this proposal was examined in detail on 26 April 2016. In general, the conclusions by the Commission concerning the general scope and ambition of the proposal were shared by delegations.

The Permanent Representatives Committee discussed the proposal on the basis of guidance questions on 5 July 2017.

7. Progress at Working Party level has in the meantime reached a stage that makes it seem appropriate for the Presidency to submit the full text of the proposal as set out in the annex to this note to the Permanent Representatives Committee in order to reach a mandate for negotiations with the European Parliament on the file.

There is general support of the Member States for the overall objectives of the proposal. There is one outstanding issue - the permitted Cadmium level for organo-mineral and inorganic fertilisers (Annex I, PFC 1, (B) and (C)). See under III: This will need a further exchange of views at Coreper level.

III. MAIN POLITICAL ISSUES

8. The issue of the permitted Cadmium levels for organo-mineral and inorganic fertilisers (Annex I PFC 1 (B) and PFC 1 (C)) needs to be discussed by Coreper. Following the last WP meeting on 6 November 2017, the Presidency has elaborated another compromise option building on a Presidency paper of 27 October, a paper by the Italian delegation of 3 November and another compromise wording by the Presidency from 17 November. The new compromise wording has been inserted into the text of the proposal (see annex to this note, page 101 for Annex I PFC 1 (B) and page 109 for Annex I PFC 1 (C)).

The Presidency invites delegations to scrutinise and assess this compromise in a constructive manner taking into account the fact that negotiations with the European Parliament have to start on the basis of a text reflecting the position of as many Member States as possible.

IV. CONCLUSION

9. The Permanent Representatives Committee is invited to endorse the text as set out in the annex to this note and to mandate the Presidency to begin informal trilogue meetings with the representatives of the European Parliament,

Proposal for a

REGULATION OF THE EUROPEAN PARLIAMENT AND OF THE COUNCIL

laying down rules on the making available on the market of ~~CE-marked~~ EU fertilising products and amending Regulations (EC) No 1069/2009 and (EC) No 1107/2009

(Text with EEA relevance)

THE EUROPEAN PARLIAMENT AND THE COUNCIL OF THE EUROPEAN UNION,

Having regard to the Treaty on the Functioning of the European Union, and in particular Article 114 thereof,

Having regard to the proposal from the European Commission,

After transmission of the draft legislative act to the national parliaments,

Having regard to the opinion of the European Economic and Social Committee¹,

Acting in accordance with the ordinary legislative procedure,

Whereas:

¹ OJ C , , p. .

- (1) The conditions for making fertilisers available on the internal market have been partially harmonised through Regulation (EC) No 2003/2003 of the European Parliament and of the Council², which almost exclusively covers fertilisers from mined or chemically produced, inorganic materials. There is also a need to make use of recycled or organic materials for fertilising purposes. Harmonised conditions for making fertilisers made from such recycled or organic materials available on the entire internal market should be established in order to provide an important incentive for their further use. The scope of the harmonisation should therefore be extended in order to include recycled and organic materials.
- (2) Certain products are being used in combination with fertilisers for the purpose of improving nutrition efficiency, with the beneficial effect of reducing the amount of fertilisers used and hence their environmental impact. In order to facilitate their free movement on the internal market, not only fertilisers, i.e. products intended to provide plants with nutrient, but also products intended to improve plants' nutrition efficiency, should be covered by the harmonisation.
- (3) Regulation (EC) No 765/2008 of the European Parliament and of the Council³ lays down rules on the accreditation of conformity assessment bodies, provides a framework for the market surveillance of products and for controls on products from third countries, and lays down the general principles of the CE marking. That Regulation should be applicable to products covered by the scope of this Regulation in order to ensure that products benefiting from the free movement of goods within the Union fulfil requirements providing a high level of protection of public interests such as **human, animal and plant** health, and safety in general, protection of consumers and protection of the environment.

² Regulation (EC) No 2003/2003 of the European Parliament and of the Council of 13 October 2003 relating to fertilisers (OJ L 304, 21.11.2003, p. 1).

³ Regulation (EC) No 765/2008 of the European Parliament and of the Council of 9 July 2008 setting out the requirements for accreditation and market surveillance relating to the marketing of products and repealing Regulation (EEC) No 339/93 (OJ L 218, 13.8.2008, p. 30).

- (4) Decision No 768/2008/EC of the European Parliament and of the Council⁴ lays down common principles and reference provisions intended to apply across sectoral legislation in order to provide a coherent basis for revision or recasts of that legislation. Regulation (EC) No 2003/2003 should therefore be replaced by a Regulation drafted to the extent possible in accordance with that Decision.
- (5) Contrary to most other product harmonisation measures in Union legislation, Regulation (EC) No 2003/2003 does not prevent non-harmonised fertilisers from being made available on the internal market in accordance with national law and the general free movement rules of the Treaty. In view of the very local nature of certain product markets, this possibility should remain. Compliance with harmonised rules should therefore remain optional, and should be required only for products, intended to provide plants with nutrient or improve plants' nutrition efficiency, which are CE marked when made available on the market. This Regulation should therefore not apply to products which are not CE marked when made available on the market.

⁴ Decision No 768/2008/EC of the European Parliament and of the Council of 9 July 2008 on a common framework for the marketing of products, and repealing Council Decision 93/465/EEC (OJ L 218, 13.8.2008, p. 82).

(6) Different product functions warrant different product safety and quality requirements adapted to their different intended uses. ~~CE marked~~ EU fertilising products should therefore be divided into different product function categories, which should each be subject to specific safety and quality requirements.

(6a) An EU fertilising product may have more than one of the functions described in the product function categories of this Regulation. Where only one of those functions is claimed, it should be sufficient for the product to comply with the requirements of the product function category describing that claimed function. By contrast, where more than one of those functions are claimed, the EU fertilising product should be regarded as a blend of two or more component fertilising products, and compliance should be required for each of the component fertilising products with respect to its function. A specific product function category should therefore cover such blends.

(6b) A manufacturer using one or more EU fertilising products that have already been subject to a conformity assessment, by that manufacturer or another manufacturer, may wish to rely on that conformity assessment. For the purpose of reducing the administrative burden to a minimum, the resulting EU fertilising product should also be regarded as a blend of two or more component fertilising products, and the additional conformity requirements for the blend should be reduced to the aspects warranted by the blending.

- (7) ~~Similarly~~, Different component materials warrant different process requirements and control mechanisms adapted to their different potential hazardousness and variability. Component materials for ~~CE-marked~~ EU fertilising products should therefore be divided into different categories, which should each be subject to specific process requirements and control mechanisms. It should be possible to make available on the market a ~~CE-marked~~ EU fertilising product composed of several component materials from various component material categories, where each material complies with the requirements of the category to which the material belongs.
- (8) Contaminants in ~~CE-marked~~ EU fertilising products, such as cadmium, can potentially pose a risk ~~to human and animal health and the environment~~ as they accumulate in the environment and enter the food chain. Their content should therefore be limited in such products. Furthermore, impurities in ~~CE-marked~~ EU fertilising products derived from bio-waste, in particular polymers but also metal and glass, should be either prevented or limited to the extent technically feasible by detection of such impurities in separately collected bio-waste before processing.

- (9) **An EU fertilising product** Products complying with all the requirements of this Regulation should be allowed to move freely on the internal market. Where one or more of the component materials in a CE-marked EU fertilising product falls **is a derived product** within the scope of Regulation (EC) No 1069/2009 of the European Parliament and of the Council, but **has reached** reaches a point in the manufacturing chain beyond which it no longer poses any significant risk to public or animal health (the 'end point in the manufacturing chain'), it would represent an unnecessary administrative burden to continue subjecting the product⁵ to the provisions of that Regulation. Such fertilising products should therefore be excluded from the requirements of that Regulation. Regulation (EC) No 1069/2009 should therefore be amended accordingly.

(9a) Recalling that certain Member States have been granted derogations from Article 5 of Regulation (EC) No 2003/2003 in accordance with the Treaties relating to cadmium content in phosphate fertilisers on the grounds, inter alia, of the protection of human health and the environment in the context of particular soil and climactic conditions prevailing in those Member States, and noting that the factual circumstances that led to the granting of those derogations by the Commission remain valid, those Member States should be able to continue to apply their national limit levels for cadmium content in EU fertilising products until such a point that a harmonised limit level for cadmium content which is equal to or lower than that limit level is applicable at Union level.

- (10) **For each component material category which includes derived products within the meaning of Regulation (EC) No 1069/2009,** ~~the~~ The end point in the manufacturing chain should be determined for each relevant component material containing animal by-products in accordance with the procedures laid down in **that** Regulation (EC) No 1069/2009. Where **such an end point is reached before the EU fertilising product is placed on the market but after the manufacturing process regulated under this Regulation has started,** a manufacturing process regulated under this Regulation starts already before that end point has been reached, the process requirements of both Regulation (EC) No 1069/2009 and this Regulation should apply cumulatively to CE-marked EU fertilising products, which means application of the stricter requirement in case both Regulations regulate the same parameter.

⁵ BG: Replace "product" by "component material". Cion: No, we mean product here.

- (11) In the event of risks to public or animal health from ~~CE marked~~ **EU** fertilising products derived from animal by-products, recourse to safeguard measures in accordance with Regulation (EC) No 178/2002 of the European Parliament and of the Council⁶ should be possible, as is the case for other categories of products derived from animal by-products.
- (12) **The making available on the market of an animal by-product or a derived product for which no** ~~Where one or more of the component materials for a CE marked~~ **EU** fertilising product fall within the scope of Regulation (EC) No 1069/2009 and has not reached the end point in the manufacturing chain **has been defined, or for which the defined end point has not been reached at the time of making available on the market,** it would be misleading to provide for the product's ~~CE marking under this Regulation, since the making available on the market of such a product is subject to the requirements of Regulation (EC) No 1069/2009.~~ Therefore, **it would be misleading to provide for the product's CE marking under this Regulation. Any product containing or consisting of** such **an animal by-product or derived** products should **therefore** be excluded from the scope of this Regulation.
- (13) For certain recovered wastes within the meaning of Directive 2008/98/EC of the European Parliament and of the Council⁷, a market demand for their use as fertilising products has been identified. Furthermore, certain requirements are necessary for the waste used as input in the recovery operation and for the treatment processes and techniques, as well as for fertilising products resulting from the recovery operation, in order to ensure that the use of those products does not lead to overall adverse environmental or human health impacts. For ~~CE marked~~ **EU** fertilising products, those requirements should be laid down in this Regulation. Therefore, as of the moment of compliance with all the requirements of this Regulation, such products should cease to be regarded as waste within the meaning of Directive 2008/98/EC.

⁶ Regulation (EC) No 178/2002 of the European Parliament and of the Council of 28 January 2002 laying down the general principles and requirements of food law, establishing the European Food Safety Authority and laying down procedures in matters of food safety (OJ L 31, 1.2.2002, p. 1).

⁷ Directive 2008/98/EC of the European Parliament and of the Council on waste and repealing certain Directives (OJ L 312, 22.11.2008, p. 3).

- (14) Certain substances and mixtures, commonly referred to as **inhibitors**, improve the nutrient release pattern of a nutrient in a fertiliser **by delaying or stopping the activity of specific groups of micro-organisms or enzymes**. Substances and mixtures made available on the market with the intention of them being added to ~~CE-marked~~ fertilising products for that purpose should fulfil certain efficacy criteria at the responsibility of the manufacturer of those substances or mixtures, and should therefore as such be considered as ~~CE-marked~~ **EU** fertilising products under this Regulation. Furthermore, ~~CE-marked~~ **EU** fertilising products containing such substances or mixtures should be subject to certain efficacy and safety criteria. Such substances and mixtures should therefore also be regulated as component materials for ~~CE-marked~~ **EU** fertilising products.
- (15) Certain substances, mixtures and micro-organisms, commonly referred to as plant biostimulants, are not as such nutrients, but nevertheless stimulate plants' nutrition processes. Where such products aim solely at improving the plants' nutrient use efficiency, tolerance to abiotic stress, or ~~crop~~ quality traits, they are by nature more similar to fertilising products than to most categories of plant protection products. Such products should therefore be eligible for CE marking under this Regulation and excluded from the scope of Regulation (EC) No 1107/2009 of the European Parliament and of the Council⁸. Regulation (EC) No 1107/2009 should therefore be amended accordingly.
- (16) Products with one or more functions, one of which is covered by the scope of Regulation (EC) No 1107/2009, **are plant protection products covered by the scope of that Regulation.** **Those products** should remain under the control tailored for such products and provided for by that Regulation. Where such products also have the function of a fertilising product, it would be misleading to provide for their CE marking under this Regulation, since the making available on the market of a plant protection product is contingent on a product authorisation valid in the Member State in question. Therefore, such products should be excluded from the scope of this Regulation.

⁸ Regulation (EC) No 1107/2009 of the European Parliament and of the Council of 21 October 2009 concerning the placing of plant protection products on the market and repealing Council Directives 79/117/EEC and 91/414/EEC (OJ L 309, 24.11.2009, p. 1).

(17) This Regulation should not prevent the application of existing Union legislation relating to aspects of protection of health, safety and the environment not covered by this Regulation. This Regulation should therefore apply without prejudice to Council Directive 86/278/EEC⁹, Council Directive 89/391/EEC¹⁰, Regulation (EC) No 1907/2006 of the European Parliament and of the Council¹¹, Regulation (EC) No 1272/2008 of the European Parliament and of the Council¹², Commission Regulation (EC) No 1881/2006¹³, ~~Council Directive 2000/29/EC¹⁴~~ **Regulation (EU) No 2031/2016**, Regulation (EU) No 98/2013 of the European Parliament and of the Council¹⁵, ~~and~~ Regulation (EU) No 1143/2014 of the European Parliament and of the Council¹⁶, **Directive 2004/852/EC, Directive 2016/2284/EC; Regulation (EC) No. Directive 882/2004/882/EC, and Regulation (EC) No 834/2007.**

-
- ⁹ Council Directive 86/278/EEC of 12 June 1986 on the protection of the environment, and in particular of the soil, when sewage sludge is used in agriculture (OJ L 181, 4.7.1986, p. 6).
- ¹⁰ Council Directive 89/391/EEC of 12 June 1989 on the introduction of measures to encourage improvements in the safety and health of workers at work (OJ L 183, 29.6.1989, p. 1).
- ¹¹ Regulation (EC) No 1907/2006 of the European Parliament and of the Council of 18 December 2006 concerning the Registration, Evaluation, Authorisation and Restriction of Chemicals (REACH) (OJ L 396, 30.12.2006, p. 1).
- ¹² Regulation (EC) No 1272/2008 of the European Parliament and of the Council of 16 December 2008 on classification, labelling and packaging of substances and mixtures (OJ L 353, 31.12.2008, p. 1).
- ¹³ Commission Regulation (EC) No 1881/2006 of 19 December 2006 setting maximum levels for certain contaminants in foodstuffs (OJ L 364, 20.12.2006, p. 5).
- ¹⁴ Council Directive 2000/29/EC of 8 May 2000 on protective measures against the introduction into the Community of organisms harmful to plants or plant products and against their spread within the Community (OJ L 169, 10.7.2000, p. 1).
- ¹⁵ Regulation (EU) No 98/2013 of the European Parliament and of the Council of 15 January 2013 on the marketing and use of explosives precursors (OJ L 39, 9.2.2013, p. 1).
- ¹⁶ Regulation (EU) No 1143/2014 of the European Parliament and of the Council of 22 October 2014 on the prevention and management of the introduction and spread of invasive alien species (OJ L 317, 4.11.2014, p. 35).

- (18) Where a ~~CE-marked~~ **EU** fertilising product contains a substance or mixture within the meaning of Regulation (EC) No 1907/2006, the safety of its constituent substances for the intended use should be established through registration pursuant to that Regulation. The information requirements should ensure that the safety of the intended use of the ~~CE-marked~~ **EU** fertilising product is demonstrated in a manner comparable to that achieved through other regulatory regimes for products intended for use on arable soil or crops, notably Member States' national fertiliser legislation and Regulation (EC) No 1107/2009. Therefore, where the actual quantities placed on the market are lower than 10 tonnes per company per year, the information requirements determined by Regulation (EC) No 1907/2006 for the registration of substances in quantities of 10 to 100 tonnes should exceptionally apply as a condition for **use in EU fertilising products** ~~making available pursuant to this Regulation.~~
- (19) Where the actual quantities of substances in ~~CE-marked~~ **EU** fertilising products regulated by this Regulation are higher than 100 tonnes, the additional information requirements laid down in Regulation (EC) No 1907/2006 should apply directly by virtue of that Regulation. The application of the other provisions of Regulation (EC) No 1907/2006 should also remain unaffected by this Regulation.

- (20) ~~A blend of different CE marked EU fertilising products, each of which has been subject to a successful assessment of conformity with the applicable requirements for that material, can itself be expected to be suitable for use as a CE marked EU fertilising product, subject only to certain additional requirements warranted by the blending. Therefore, in order to avoid an unnecessary administrative burden, such blends should belong to a separate category, for which the conformity assessment should be limited to the additional requirements warranted by the blending.~~
- (21) Economic operators should be responsible for the compliance of ~~CE marked~~ EU fertilising products with this Regulation, in relation to their respective roles in the supply chain, so as to ensure a high level of protection of the aspects of public interest covered by this Regulation, and also to guarantee fair competition on the internal market.
- (22) It is necessary to provide for a clear and proportionate distribution of obligations which correspond to the role of each economic operator in the supply and distribution chain.

- (23) The manufacturer, having detailed knowledge of the design and production process, is best placed to carry out the conformity assessment procedure. Conformity assessment of ~~CE~~ marked-EU fertilising products should therefore remain solely the obligation of the manufacturer.
- (24) It is necessary to ensure that ~~CE~~ marked-EU fertilising products from third countries that enter the internal market comply with this Regulation, and in particular that the appropriate conformity assessment procedures have been carried out by manufacturers with regard to those fertilising products. Provision should therefore be made for importers to make sure that ~~CE~~ marked-EU fertilising products which they place on the market comply with the requirements of this Regulation and that they do not place on the market ~~CE~~ marked-EU fertilising products which do not comply with such requirements or present a risk to ~~human, animal or plant health, safety or the environment~~. Provision should also be made for such importers to make sure that conformity assessment procedures have been carried out and that marking of ~~CE~~ marked-EU fertilising products and documentation drawn up by manufacturers are available for inspection by the competent national authorities.
- (25) When placing a ~~CE~~ marked-EU fertilising product on the market, the importer should indicate on the packaging of the fertilising product his or her name, registered trade name or registered trade mark and the postal address at which he or she can be contacted, in order to enable market surveillance.

- (26) Since the distributor makes a ~~CE-marked~~EU fertilising product available on the market after it has been placed on the market by the manufacturer or the importer, he or she should act with due care to ensure that his or her handling of the fertilising product does not adversely affect the compliance of that product with this Regulation.
- (27) An economic operator who either places a ~~CE-marked~~EU fertilising product on the market under his or her own name or trade mark or modifies a ~~CE-marked~~EU fertilising product in such a way that compliance with the provisions of this Regulation may be affected should be considered to be the manufacturer and should assume the obligations of the manufacturer. **In other cases, economic operators who only package or repackage EU fertilising products already placed on the market by other economic operators should be able to prove that compliance with the requirements set by this Regulation have not been affected, by indicating their identity on the package and keep a copy of the original labelling information.**
- (28) Since distributors and importers are close to the market place, they should be involved in market surveillance tasks carried out by competent national authorities, and should be required to participate actively and provide those authorities with all necessary information relating to the ~~CE-marked~~EU fertilising product.
- (29) Ensuring traceability of a ~~CE-marked~~EU fertilising product throughout the whole supply chain helps to make market surveillance simpler and more efficient. An efficient traceability system facilitates market surveillance authorities' task of tracing economic operators who made non-compliant ~~CE-marked~~EU fertilising products available on the market. When keeping the information required for the identification of other economic operators, economic operators should not be required to update such information in respect of other economic operators who have either supplied them with a ~~CE-marked~~EU fertilising product or to whom they have supplied a ~~CE-marked~~EU fertilising product, since such updated information is normally not available to them.

- (30) In order to facilitate the assessment of conformity with ~~safety and quality~~ **the requirements of this Regulation** it is necessary to provide for a presumption of conformity for ~~CE marked EU~~ fertilising products which are in conformity with harmonised standards that are adopted in accordance with Regulation (EU) No 1025/2012 of the European Parliament and of the Council¹⁷.
- (31) Where harmonised standards have not been adopted, or do not ~~with sufficient detail cover all elements of the quality and~~ **satisfy the** safety requirements ~~laid down in~~ **of** this Regulation, **which they aim to cover**, uniform conditions for implementing those requirements may be needed. The Commission should therefore be empowered to adopt implementing acts setting out those conditions in common specifications. ~~For reasons of legal certainty, it should be clarified that CE marked EU fertilising products must comply with such specifications even if they are considered to be in conformity with harmonised standards.~~

¹⁷ Regulation (EU) No 1025/2012 of the European Parliament and of the Council of 25 October 2012 on European standardisation, amending Council Directives 89/686/EEC and 93/15/EEC and Directives 94/9/EC, 94/25/EC, 95/16/EC, 97/23/EC, 98/34/EC, 2004/22/EC, 2007/23/EC, 2009/23/EC and 2009/105/EC of the European Parliament and of the Council and repealing Council Decision 87/95/EEC and Decision No 1673/2006/EC of the European Parliament and of the Council (OJ L 316, 14.11.2012, p. 12).

(32) In order to enable the economic operators to demonstrate and the competent authorities to verify that ~~CE marked~~ **EU** fertilising products made available on the market comply with the requirements, it is necessary to provide for conformity assessment procedures. Decision No 768/2008/EC establishes modules for conformity assessment procedures, from the least to the most stringent, in proportion to the level of risk involved and the level of safety required. In order to ensure inter-sectoral coherence and to avoid ad-hoc variants, conformity assessment procedures should be chosen from among those modules. **It should be possible for a manufacturer to choose a more stringent conformity assessment procedure for the assessment of a product eligible for a less stringent procedure, since that possibility can allow the manufacturer to streamline his or her administration without jeopardising the product's conformity.** However, **Furthermore,** it is necessary to adapt ~~the those~~ modules **established by Decision No 786/2008/EC** in order to reflect specific aspects of fertilising products. In particular, it is necessary to reinforce the quality systems and the involvement of notified bodies for the conformity assessment of certain CE marked EU fertilising products derived from recovered waste.

- (33) In order to ensure that CE marked ammonium nitrate fertilisers of high nitrogen content do not endanger safety, and that such fertilisers are not used for purposes other than those for which they are intended, for example as explosives, such fertilisers should be subject to specific requirements relating to detonation resistance testing and to traceability.
- (34) To ensure effective access to information for market surveillance purposes, information regarding conformity with all Union acts applicable to ~~CE-marked~~EU fertilising products should be given in the form of a single EU declaration of conformity. In order to reduce the administrative burden on economic operators, that single EU declaration of conformity may be a dossier made up of relevant individual declarations of conformity.
- (35) The CE marking, indicating the conformity of a fertilising product, is the visible consequence of a whole process comprising conformity assessment in a broad sense. General principles governing the CE marking and its relationship to other markings are set out in Regulation (EC) No 765/2008. Specific rules governing the affixing of the CE marking in the case of fertilising products should be laid down.
- (36) Certain conformity assessment procedures set out in this Regulation require the intervention of conformity assessment bodies, which are notified by the Member States to the Commission.

- (37) It is essential that all notified bodies perform their functions to the same level and under conditions of fair competition. That requires the setting of obligatory requirements for conformity assessment bodies wishing to be notified in order to provide conformity assessment services.
- (38) If a conformity assessment body demonstrates conformity with the criteria laid down in harmonised standards it should be presumed to comply with the corresponding requirements set out in this Regulation.
- (39) In order to ensure a consistent level of quality in the performance of conformity assessment of ~~CE-marked~~ EU fertilising products, it is also necessary to set requirements for notifying authorities and other bodies involved in the assessment, notification and monitoring of notified bodies.
- (40) The system set out in this Regulation should be complemented by the accreditation system provided for in Regulation (EC) No 765/2008. Since accreditation is an essential means of verifying the competence of conformity assessment bodies, it should also be used for the purposes of notification.

- (41) Due to the variable nature of certain fertilising product component materials, and the potentially irreversible nature of some of the damages to which soil and crop exposure to impurities could lead, transparent accreditation as provided for in Regulation (EC) No 765/2008, ensuring the necessary level of confidence in certificates of conformity of ~~CE~~ marked-EU fertilising products ~~containing such components~~, should be the only means of demonstrating the technical competence of conformity assessment bodies.
- (42) Conformity assessment bodies frequently subcontract parts of their activities linked to the assessment of conformity or have recourse to a subsidiary. In order to safeguard the level of protection required for ~~CE marked~~ EU fertilising products to be placed on the market, it is essential that conformity assessment subcontractors and subsidiaries fulfil the same requirements as notified bodies in relation to the performance of conformity assessment tasks. Therefore, it is important that the assessment of the competence and the performance of bodies to be notified and the monitoring of bodies already notified cover also activities carried out by subcontractors and subsidiaries.
- (43) It is necessary to provide for an efficient and transparent notification procedure and, in particular, to adapt it to new technologies so as to enable online notification.
- (44) Since the services offered by notified bodies may relate to ~~CE marked~~ EU fertilising products made available on the market throughout the Union, it is appropriate to give the other Member States and the Commission the opportunity to raise objections concerning a notified body. It is therefore important to provide for a period during which any doubts or concerns as to the competence of conformity assessment bodies can be clarified before they start operating as notified bodies.

- (45) In the interest of easing market access, it is crucial that notified bodies apply the conformity assessment procedures without creating unnecessary burdens for economic operators. For the same reason, and to ensure equal treatment of economic operators, consistency in the technical application of the conformity assessment procedures needs to be ensured. That can best be achieved through appropriate coordination and cooperation between notified bodies.
- (46) In order to ensure legal certainty, it is necessary to clarify that rules on internal market surveillance and control of products entering the internal market provided for in Regulation (EC) No 765/2008 apply to ~~CE marked~~ **EU** fertilising products covered by this Regulation. This Regulation should not prevent Member States from choosing the competent authorities to carry out those tasks.
- (47) ~~CE marked~~ **EU** fertilising products should be placed on the market only if they are sufficiently effective and do not present ~~unacceptable risks to human, animal or plant health, to safety or to the environment~~ when properly stored and used for their intended purpose, and under conditions of use which can be reasonably foreseen, that is when such use could result from lawful and readily predictable human behaviour. ~~Therefore, requirements for safety and quality, as well as appropriate control mechanisms, should be established. Furthermore, the intended use of CE marked EU fertilising products should not lead to food or feed becoming unsafe.~~

- (48) Regulation (EC) No 2003/2003 provides for a safeguard procedure allowing the Commission to examine the justification for a measure taken by a Member State against EC fertilisers considered to constitute a risk. In order to increase transparency and to reduce processing time, it is necessary to improve the existing safeguard procedure, with the view to making it more efficient and drawing on the expertise available in Member States.
- (49) The existing system should be supplemented by a procedure under which interested parties are informed of measures intended to be taken with regard to ~~CE marked~~ EU fertilising products presenting an unacceptable risk to human, animal or plant health, to safety or to the environment. It should also allow market surveillance authorities, in cooperation with the relevant economic operators, to act at an early stage in respect of such fertilising products.

(49a) Market surveillance authorities' obligations under this Regulation to require economic operators to take corrective actions should only apply to products bearing the CE marking when made available on the market. That obligation should therefore be without prejudice to any possibility existing under national law to allow the economic operator remove the CE marking and legally place the product on the market as a product not covered by the scope of this Regulation.

- (50) Where the Member States and the Commission agree as to the justification of a measure taken by a Member State, further involvement of the Commission should be required only where non-compliance can be attributed to shortcomings of in a harmonised standard, in which case the procedure of formal objection to harmonised standards laid down in Regulation (EU) No 1025/2012 should apply, or to shortcomings in a common specification, in which case an implementing act amending or repealing the common specification should be adopted.

- (51) In order to ensure uniform conditions for the implementation of this Regulation, implementing powers should be conferred on the Commission. Those powers should be exercised in accordance with Regulation (EU) No 182/2011 of the European Parliament and of the Council¹⁸.
- (52) The advisory procedure should be used for the adoption of implementing acts requiring the notifying Member State to take the necessary corrective measures in respect of notified bodies that do not meet or no longer meet the requirements for their notification, since such acts do not fall within the ambit of Article 2(2) of Regulation (EU) No 182/2011.
- (53) The examination procedure should be used for the adoption of implementing acts with respect to compliant ~~CE marked~~ EU fertilising products which present an ~~unacceptable risk to human, animal or plant health, to safety or to the environment~~, since such acts fall within the ambit of Article 2(2) of Regulation (EU) No 182/2011. For the same reason, it should also be used for the adoption, amendment or repeal of common specifications.
- (54) The Commission should, by means of implementing acts, determine whether measures taken by Member States in respect of non-compliant ~~CE marked~~ EU fertilising products are justified or not. Since those acts will relate to the question whether national measures are justified, there is no need for the acts to be subject to control by the Member States.

¹⁸ Regulation (EU) No 182/2011 of the European Parliament and of the Council of 16 February 2011 laying down the rules and general principles concerning mechanisms for control by Member States of the Commission's exercise of implementing powers (OJ L 55, 28.2.2011, p.13).

- (55) Promising technical progress is being made in the field of recycling of waste, such as phosphorus recycling from sewage sludge, and fertilising product production from animal by-products, such as biochar. It should be possible for products containing or consisting of such materials to access the internal market without unnecessary delay when the manufacturing processes have been scientifically analysed and process requirements have been established at Union level. For that purpose, the power to adopt acts in accordance with Article 290 of the Treaty on the Functioning of the European Union should be delegated to the Commission in respect of defining and introducing ~~larger or additional categories of CE marked EU~~ ~~fertilising products or~~ component materials eligible for use in the production of EU fertilising products and corresponding contaminant limits in such products. The empowerment should only apply to the extent justified by technical progress established after the adoption of this Regulation, and not for the purpose of amending any elements of this Regulation in the absence of new evidence of such progress. In order to base the introduction of new contaminant limits in products on full consideration of direct and indirect impact on the food and feed safety, a scientific opinion of European Food Safety Authority should be requested prior to the adoption of new contaminant limits. For **products derived from** animal by-products, component material categories should be expanded or added only to the extent an end point in the manufacturing chain has been determined in accordance with the procedures laid down in Regulation (EC) No 1069/2009, since animal by-products for which no such end point has been determined are in any event excluded from the scope of this Regulation.
- (56) Furthermore, it should be possible to react immediately to new findings regarding the conditions for ~~CE marked EU~~ EU fertilising products to be sufficiently effective and to new risk assessments regarding human, animal or plant health, safety or the environment. For that purpose, the power to adopt acts in accordance with Article 290 of the Treaty should be delegated to the Commission to amend the requirements applicable to various categories of ~~CE marked EU~~ EU fertilising products.

(57) In order to achieve the objectives of this Regulation, the power to adopt acts in accordance with Article 290 of the Treaty on the Functioning of the European Union should be delegated to the Commission in respect of the adaptation to technical progress, in particular in the field of fertilising product production from animal by-products, of waste recovery, in the agricultural sector and the agro-food industry. It is of particular importance that the Commission carry out appropriate consultations during its preparatory work, including at expert level, and that those consultations be conducted in accordance with the principles laid down in the Interinstitutional Agreement on Better Law-Making of 2016. In particular, to ensure equal participation in the preparation of delegated acts, the European Parliament and the Council receive all documents at the same time as Member States' experts, and their experts systematically have access to meetings of Commission expert groups dealing with the preparation of delegated acts. ~~In exercising those powers, it is of particular importance that the Commission carry out appropriate consultations during its preparatory work, including at expert level. The Commission, when preparing and drawing up delegated acts, should ensure a simultaneous, timely and appropriate transmission of relevant documents to the European Parliament and to the Council.~~

(58) Member States should lay down rules on penalties applicable to infringements of this Regulation and ensure that those rules are enforced. The penalties provided for should be effective, proportionate and dissuasive.

(58a) Since micro-organisms are not subject to registration under Regulation (EC) No 1907/2006, or any other general legislation requiring manufacturers to demonstrate that the intended use is safe, they should be eligible as component materials for fertilising products only to the extent that they have been clearly identified and supported by data demonstrating that their use is safe, and indicated in an exhaustive list adopted on this basis. The same criteria should apply to the Commission's delegation of power to add new micro-organisms to that exhaustive list.

(58b) In view of the need to ensure a high level of environmental protection, and in view of the need to take into account new developments based on scientific facts, a review clause is needed in relation to limit levels for cadmium content.

(59) It is necessary to provide for transitional arrangements that allow the making available on the market of EC fertilisers that have been placed on the market in accordance with Regulation (EC) No 2003/2003 before the date of application of this Regulation without those products having to comply with further product requirements. Distributors should therefore be able to supply EC fertilisers that have been placed on the market, namely stock that is already in the distribution chain, before the date of application of this Regulation.

- (60) It is necessary to provide for sufficient time for economic operators to comply with their obligations under this Regulation, and for Member States to set up the administrative infrastructure necessary for its application. The application should therefore be deferred to a date where those preparations can reasonably be finalised.
- (61) Since the objective of this Regulation, namely to guarantee the functioning of the internal market while ensuring that ~~CE-marked~~ EU fertilising products on the market fulfil the requirements providing for a high level of protection of human, animal, and plant health, safety and the environment, cannot be sufficiently achieved by the Member States but can rather, by reason of its scale and effects, be better achieved at Union level, the Union may adopt measures, in accordance with the principle of subsidiarity as set out in Article 5 of the Treaty on European Union. In accordance with the principle of proportionality, as set out in that Article, this Regulation does not go beyond what is necessary in order to achieve that objective,

HAVE ADOPTED THIS REGULATION:

CHAPTER 1

GENERAL PROVISIONS

Article 1

Scope

1. This Regulation shall apply to ~~CE marked~~ EU fertilising products.

However, this Regulation shall not apply to the following products:

- (a) animal by-products **or derived products** which are **made available on the market** subject to the requirements of Regulation (EC) No 1069/2009,
- (b) plant protection products covered by the scope of Regulation (EC) No 1107/2009.

2. This Regulation shall not affect the application of the following acts :

- (a) Directive 86/278/EEC;
- (b) Directive 89/391/EEC;
- (c) Regulation (EC) No 1907/2006;
- (d) Regulation (EC) No 1272/2008;
- (e) Regulation (EC) No 1881/2006;
- (f) ~~Directive 2000/29/EC~~; **Regulation (EU) No 2031/2016**
- (g) Regulation (EU) No 98/2013;

(h) Regulation (EU) No 1143/2014.

(ha) Directive 2004/852/EC;

(haa) Directive 2016/2284/EC;

(hb) Regulation (EC) No 882/2004;

(hbc) Regulation (EU) 2017/625 (from 15 December 2019 on)

(hc) Regulation (EC) No 834/2007.

(hd) Directive 2001/18/EC

Article 2

Definitions

For the purposes of this Regulation, the following definitions shall apply:

- (1) ‘fertilising product’ means a substance, mixture, micro organism or any other material, applied or intended to be applied ~~either on its own or mixed with another material~~ on plants or their rhizosphere **or on mushrooms or their mycosphere, or intended to constitute the rhizosphere or mycosphere, either on its own or mixed with another material,** for the purpose of providing ~~the~~ plants **or mushrooms** with nutrient or improving their nutrition efficiency;
 - (2) ‘~~CE marked~~ **EU** fertilising product’ means a fertilising product which is CE marked when made available on the market;
- (2a) ‘Presenting a risk’ means having the potential to affect adversely human, animal or plant health, safety or the environment to a degree which goes beyond that considered reasonable and acceptable in relation to the intended purpose or under the normal or reasonably foreseeable conditions of use;**

- (3) 'substance' means a substance within the meaning of Article 3(1) of Regulation (EC) No 1907/2006;
- (4) 'mixture' means a mixture within the meaning of Article 3(2) of Regulation (EC) No 1907/2006;
- (5) 'micro-organism' means a micro-organism within the meaning of Article 3(15) of Regulation (EC) No 1107/2009;

(5a) 'liquid form' means a suspension or a solution, where a suspension is a two-phase dispersion in which solid particles are maintained in suspension in the liquid phase, and a solution is a liquid that is free of solid particles, by convention, or a gel should be considered as belonging to this category;

(5b) 'solid form' means form characterized by structural rigidity and resistance to changes of shape or volume and in which the atoms are tightly bound to each other, either in a regular geometric lattice (crystalline solids) or irregularly (an amorphous solid), and includes pastes.

(5c) '% by mass' means a percentage of the mass of the entire fertilising product in the form in which it is made available on the market;

- (6) ‘making available on the market’ means any supply of a ~~CE-marked~~EU fertilising product for distribution or use on the Union market in the course of a commercial activity, whether in return for payment or free of charge;
- (7) ‘placing on the market’ means the first making available of a ~~CE-marked~~EU fertilising product on the Union market;
- (8) ‘manufacturer’ means **any** a natural or legal person who manufactures a ~~CE-marked~~EU fertilising product or has a ~~CE-marked~~EU fertilising product designed or manufactured, and markets that fertilising product under his or her name or trademark;
- (9) ‘authorised representative’ means a natural or legal person established within the Union who has received a written mandate from a manufacturer to act on his or her behalf in relation to specified tasks;
- (10) ‘importer’ means any natural or legal person established within the Union who places a ~~CE-marked~~EU fertilising product from a third country on the Union market;

- (11) ‘distributor’ means any natural or legal person in the supply chain, other than the manufacturer or the importer, who makes a ~~CE-marked~~ EU fertilising product available on the market;
- (12) ‘economic operators’ means manufacturers, authorised representatives, importers and distributors;
- (13) ‘technical specification’ means a document that prescribes technical requirements to be fulfilled by a ~~CE-marked~~ EU fertilising product, **by its production process or by the methods for its sampling and analysis**;
- (14) ‘harmonised standard’ means harmonised standard as defined in Article 2(1)(c) of Regulation (EU) No 1025/2012;
- (15) ‘accreditation’ means accreditation as defined in Article 2(10) of Regulation (EC) No 765/2008;
- (16) ‘national accreditation body’ means national accreditation body as defined in Article 2(11) of Regulation (EC) No 765/2008;
- (17) ‘conformity assessment’ means the process demonstrating whether the requirements provided in this Regulation relating to a ~~CE-marked~~ EU fertilising product have been fulfilled;
- (18) ‘conformity assessment body’ means a body that performs conformity assessment activities including testing, certification and inspection;

- (19) ‘recall’ means any measure aimed at achieving the return of a ~~CE marked~~ **EU** fertilising product that has already been made available to the end-user;
- (20) ‘withdrawal’ means any measure aimed at preventing a ~~CE marked~~ **EU** fertilising product in the supply chain from being made available on the market;
- (21) ‘CE marking’ means a marking by which the manufacturer indicates that the fertilising product is in conformity with the applicable requirements set out in Union harmonisation legislation providing for its affixing;
- (22) ‘Union harmonisation legislation’ means any Union legislation harmonising the conditions for the marketing of products.

Article 3

Free movement

(1) Member States shall not, **for reasons relating to composition, labelling or other aspects covered by this Regulation,** impede the making available on the market of ~~CE-marked~~ **EU** fertilising products which comply with this Regulation.

(1a) By derogation from paragraph 1, those Member States which, on [please insert the date one day before the entry into force of this Regulation] benefit from a derogation from Article 5 of Regulation (EC) No 2003/2003 in relation to cadmium content in fertilising products granted in accordance with Article 114(4) TFEU may continue to apply the national limit level for cadmium content in phosphate fertilisers which is applicable in that Member State on [please insert the date one day before the entry into force of this Regulation] to EU fertilising products until such a point that a harmonised limit level for cadmium content in phosphate fertilisers which is equal to or lower than the limit level applicable in the Member State concerned on [please insert the date one day before the entry into force of this Regulation] is applicable at Union level.

(2) This Regulation shall not prevent Member States from maintaining or adopting provisions, which are in compliance with the Treaties, concerning the use of EU fertilising products for the purpose of protecting human health and the environment, provided that those provisions do not require modification of EU fertilising products which are in compliance with this Regulation and do not influence the conditions for making them available on the market.

Article 4

Product requirements

1. A ~~CE marked~~ **EU** fertilising product shall
 - (a) meet the requirements set out in Annex I for the relevant product function category;
 - (b) meet the requirements set out in Annex II for the relevant component material category or categories;
 - (c) be labelled in accordance with the labelling requirements set out in Annex III.
 - ~~2. For any aspects not covered by Annex I or II, CE marked EU fertilising products shall meet the requirement that their use, as specified in the use instructions, does not lead to food or feed of plant origin becoming unsafe within the meaning of Articles 14 and 15 of Regulation (EC) No 178/2002, respectively.~~
- 2a. For any aspects not covered by Annex I or II, EU fertilising products shall not present a risk as defined in Article 2 (2a).**

Article 5

Making available on the market

~~CE marked~~ **EU** fertilising products may be made available on the market only if they satisfy the requirements of **this** ~~the present~~ Regulation.

CHAPTER 2

OBLIGATIONS OF ECONOMIC OPERATORS

Article 6

Obligations of manufacturers

1. When placing ~~CE marked~~ **EU** fertilising products on the market, manufacturers shall ensure that they have been designed and manufactured in accordance with the requirements set out in Annex I for the relevant product function category and the requirements set out in Annex II for the relevant component material category or categories.
2. Before placing ~~CE marked~~ **EU** fertilising products on the market, manufacturers shall draw up the technical documentation and carry out the relevant conformity assessment procedure referred to in Article 14, or have it carried out. Where compliance of such a fertilising product with the applicable requirements laid down in this Regulation has been demonstrated by that procedure, manufacturers shall affix the CE marking, **and** draw up an EU declaration of conformity ~~and ensure that the declaration accompanies the fertilising product when placed on the market.~~
3. Manufacturers shall keep the technical documentation and the EU declaration of conformity for ~~10~~ **5** years after the ~~CE marked~~ **EU** fertilising product covered by those documents has been placed on the market.

Manufacturers shall, upon request, make available a copy of the EU declaration of conformity to other economic operators.

4. Manufacturers shall ensure that procedures are in place for ~~CE-marked~~**EU** fertilising products that are part of a series production to remain in conformity with this Regulation. Changes in production method or characteristics of those fertilising products and changes in the harmonised standards, common specifications referred to in Article 13 or other technical specifications by reference to which conformity of a ~~CE-marked~~**EU** fertilising product is declared **or verified** shall be adequately taken into account.

When deemed appropriate with regard to the performance of, or the risks presented by, a ~~CE-marked~~**EU** fertilising product, manufacturers shall carry out sample testing of such fertilising products made available on the market, investigate, and, if necessary, keep a register of complaints, of non-conforming ~~CE-marked~~**EU** fertilising products and recalls of such products, and shall keep distributors informed of any such monitoring.

5. Manufacturers shall ensure that the packaging of the ~~CE-marked~~ **EU** fertilising products which they have placed on the market bears a type, batch ~~or serial~~ number or other element allowing their identification or, where the fertilising products are supplied without packaging, that the required information is provided in a document accompanying each fertilising product.
6. Manufacturers shall indicate their name, registered trade name or registered trade mark and the postal address at which they can be contacted on the packaging of the ~~CE-marked~~ **EU** fertilising product or, where the fertilising product is supplied without packaging, in a document accompanying the fertilising product. The postal address shall indicate a single point at which the manufacturer can be contacted. The contact details shall be in a language easily understood by end-users and market surveillance authorities.
7. Manufacturers shall ensure that ~~CE-marked~~ **EU** fertilising products are **accompanied by the information required under** ~~labelled in accordance with Annex III,~~ **Where the fertilising product is supplied in a package the information shall appear on a label, which is affixed to the package. However, where the package is too small to contain all the information, some information shall be provided in a separate leaflet accompanying the package. Such a leaflet shall be regarded as part of the label.** ~~or w~~ **Where** the fertilising product is supplied without packaging, that **all** the labelling statements are **information shall be** provided in **such a leaflet** document accompanying the fertilising product and accessible for inspection purposes ~~when the product is placed on the market~~. The labelling statement **information required under Annex III** shall be in a language which can be easily understood by end-users, as determined by the Member State concerned, and shall be clear, understandable and intelligible.

8. Manufacturers who consider or have reason to believe that a ~~CE-marked~~ EU fertilising product which they have placed on the market is not in conformity with this Regulation shall immediately take the corrective measures necessary to bring that fertilising product into conformity, to withdraw it or to recall it, if appropriate.

Furthermore, where manufacturers consider or have reason to believe that ~~CE-marked~~ EU fertilising products which they have placed on the market present an ~~unacceptable risk to human, animal or plant health, to safety or to the environment~~, they shall immediately inform the competent national authorities of the Member States in which they made the fertilising products available on the market to that effect, giving details, in particular, of any non-compliance and of any corrective measures taken.

9. Manufacturers shall, further to a reasoned request from a competent national authority, provide it with all the information and documentation, in paper or electronic form, necessary to demonstrate the conformity of the ~~CE-marked~~ EU fertilising product with this Regulation, in a language which can be easily understood by that authority. They shall cooperate with that authority, at its request, on any action taken to eliminate the risks posed by ~~CE-marked~~ EU fertilising products which they have placed on the market.

~~10.—The manufacturer shall submit to the competent authority of the Member State of destination a report of the detonation resistance test prescribed in Annex IV for the following CE marked **EU** fertilising products:~~

- ~~(a) —straight or compound solid inorganic macronutrient ammonium nitrate fertilisers of high nitrogen content, as specified in product function category 1(C)(I)(a)(i ii)(A) in Annex I;~~
- ~~(b) —fertilising product blends, as specified in product function category 7 in Annex I, containing a fertiliser referred to in point (a).~~

~~The report shall be submitted at least five days in advance of placing those products on the market.~~

Article 7

Authorised representative

1. A manufacturer may, by a written mandate, appoint an authorised representative.

The obligations laid down in Article 6(1) and the obligation to draw up technical documentation referred to in Article 6(2) shall not form part of the authorised representative's mandate.

2. An authorised representative shall perform the tasks specified in the mandate received from the manufacturer. The mandate shall allow the authorised representative to do at least the following:
 - (a) keep the EU declaration of conformity and the technical documentation at the disposal of national market surveillance authorities for ~~10~~ 5 years after the ~~CE-marked~~ EU fertilising product covered by those documents has been placed on the market;
 - (b) further to a reasoned request from a competent national authority, provide that authority with all the information and documentation necessary to demonstrate the conformity of a ~~CE-marked~~ EU fertilising product;
 - (c) cooperate with the competent national authorities, at their request, on any action taken to eliminate the risks posed by ~~CE-marked~~ EU fertilising products covered by the authorised representative's mandate;

Article 8

Obligations of importers

1. Importers shall place only compliant ~~CE marked~~ **EU** fertilising products on the market.
2. Before placing a ~~CE marked~~ **EU** fertilising product on the market importers shall ensure that the appropriate conformity assessment procedure referred to in Article 14 has been carried out by the manufacturer. They shall ensure that the manufacturer has drawn up the technical documentation, that the ~~CE marked~~ **EU** fertilising product is accompanied by ~~the EU declaration of conformity and~~ the required documents, and that the manufacturer has complied with the requirements set out in Article 6(5) and (6). Where an importer considers or has reason to believe that a ~~CE marked~~ **EU** fertilising product is not in conformity with ~~the applicable requirements set out in Annex I, Annex II or Annex III~~ **this Regulation**, he or she shall not place the fertilising product on the market until it has been brought into conformity. Furthermore, where the ~~CE marked~~ **EU** fertilising product presents an ~~unacceptable risk to human, animal or plant health, to safety or to the environment~~, the importer shall inform the manufacturer and the market surveillance authorities to that effect.
3. Importers shall indicate their name, registered trade name or registered trade mark and the postal address at which they can be contacted on the packaging of the ~~CE marked~~ **EU** fertilising product or, where the ~~CE marked~~ **EU** fertilising product is supplied without packaging, in a document accompanying the fertilising product. The contact details shall be in a language easily understood by end-users and market surveillance authorities.

4. Importers shall ensure that ~~CE marked~~ **EU** fertilising products are **accompanied by the information required under** ~~labelled in accordance with Annex III,~~ **Where the fertilising product is supplied in a package the information shall appear on a label, which is affixed to the package. However, where the package is too small to contain all the information, some information shall be provided in a separate leaflet accompanying the package. Such a leaflet shall be regarded as part of the label.** ~~or w~~ **Where** the fertilising product is supplied without packaging, that **all** the labelling statements are **information shall be** provided in **such** a **leaflet** document accompanying the fertilising product and accessible for inspection purposes when the product is placed on the market. The labelling statement **information** shall be in a language which can be easily understood by end-users, as determined by the Member State concerned.
5. Importers shall ensure that, while a ~~CE marked~~ **EU** fertilising product is under their responsibility, its storage or transport conditions do not jeopardise its compliance with the ~~safety and quality~~ requirements set out in Annex ~~es~~ I or ~~with the labelling requirements set out in Annex III.~~
6. When deemed appropriate with regard to the performance of or the risks presented by a ~~CE marked~~ **EU** fertilising product, importers shall carry out sample testing of such fertilising products made available on the market, investigate, and, if necessary, keep a register of complaints, of non-conforming ~~CE marked~~ **EU** fertilising products and recalls of such products, and shall keep distributors informed of any such monitoring.

7. Importers who consider or have reason to believe that a ~~CE-marked~~ **EU** fertilising product which they have placed on the market is not in conformity with this Regulation shall immediately take the corrective measures necessary to bring that fertilising product into conformity, to withdraw it or to recall it, if appropriate.

Furthermore, where importers consider or have reason to believe that ~~CE-marked~~ **EU** fertilising products which they have placed on the market present an ~~unacceptable risk to human, animal or plant health, to safety or to the environment~~, they shall immediately inform the competent national authorities of the Member States in which they made the fertilising product available on the market to that effect, giving details, in particular, of any non-compliance and of any corrective measures taken.

8. Importers shall, for ~~10~~ **5** years after the ~~CE-marked~~ **EU** fertilising product has been placed on the market, keep a copy of the EU declaration of conformity at the disposal of the market surveillance authorities and ensure that the technical documentation can be made available to those authorities, upon request.

Importers shall, upon request, make available a copy of the EU declaration of conformity to other economic operators.

9. Importers shall, further to a reasoned request from a competent national authority, provide it with all the information and documentation, in paper or electronic form, necessary to demonstrate the conformity of the ~~CE-marked~~ **EU** fertilising product in a language which can be easily understood by that authority. They shall cooperate with that authority, at its request, on any action taken to eliminate the risks posed by ~~CE-marked~~ **EU** fertilising products which they have placed on the market.

~~10.—The importer shall submit to the competent authority of the Member State of destination a report of the detonation resistance test prescribed in Annex IV for the following CE marked **EU** fertilising products:~~

- ~~(a) —straight or compound solid inorganic macronutrient ammonium nitrate fertilisers of high nitrogen content, as specified in product function category 1(C)(I)(a)(i ii)(A) in Annex I;~~
- ~~(b) —fertilising product blends, as specified in product function category 7 in Annex I, containing a fertiliser referred to in point (a).~~

~~The report shall be submitted at least five days in advance of placing those products on the market.~~

Article 9

Obligations of distributors

1. When making a ~~CE marked~~ **EU** fertilising product available on the market distributors shall act with due care in relation to the requirements of this Regulation.
2. Before making a ~~CE marked~~ **EU** fertilising product available on the market distributors shall verify that it is accompanied ~~by the EU declaration of conformity and~~ by the required documents, **including the information referred to in Article 6(7) provided as specified therein**, ~~that it is labelled in accordance with Annex III and~~ in a language which can be easily understood by end-users in the Member State in which the ~~CE marked~~ **EU** fertilising product is to be made available on the market, and that the manufacturer and the importer have complied with the requirements set out in Article 6(5) and (6) and Article 8(3) respectively.

Where a distributor considers or has reason to believe that a ~~CE marked~~ **EU** fertilising product is not in conformity with ~~the applicable requirements set out in Annex I, Annex II or Annex III~~ **this Regulation**, he or she shall not make the fertilising product available on the market until it has been brought into conformity. Furthermore, where the ~~CE marked~~ **EU** fertilising product presents an ~~unacceptable risk to human, animal or plant health, to safety or to the environment~~, the distributor shall inform the manufacturer or the importer to that effect as well as the market surveillance authorities.

3. Distributors shall ensure that, while a ~~CE~~-marked EU fertilising product is under their responsibility, its storage or transport conditions do not jeopardise its compliance with the ~~safety and quality~~ requirements set out in Annex ~~es~~ I or ~~the~~ ~~labelling~~ requirements set out in ~~Annex~~ III.
4. Distributors who consider or have reason to believe that a ~~CE~~-marked EU fertilising product which they have made available on the market is not in conformity with this Regulation shall make sure that the corrective measures necessary to bring that fertilising product into conformity, to withdraw it or to recall it, if appropriate, are taken.

Furthermore, where distributors consider or have reason to believe that ~~CE~~-marked EU fertilising products which they have made available on the market presents an ~~unacceptable~~ risk to ~~human, animal or plant health, to safety or to the environment~~, they shall immediately inform the competent national authorities of the Member States in which they made the ~~CE~~ ~~marked~~-EU fertilising product available on the market to that effect, giving details, in particular, of any non-compliance and of any corrective measures taken.

5. Distributors shall, further to a reasoned request from a competent national authority, provide it with all the information and documentation, in paper or electronic form, necessary to demonstrate the conformity of the ~~CE~~-marked EU fertilising product. They shall cooperate with that authority, at its request, on any action taken to eliminate the risks posed by ~~CE~~ ~~marked~~-EU fertilising products which they have made available on the market.

Article 10

Cases in which obligations of manufacturers apply to importers and distributors

An importer or distributor shall be considered a manufacturer for the purposes of this Regulation, and shall be subject to the obligations of the manufacturer under Article 6, where he or she places a ~~CE marked~~ **EU** fertilising product on the market under his or her name or trademark or modifies a ~~CE marked~~ **EU** fertilising product already placed on the market in such a way that compliance with this Regulation may be affected.

Article 10a

Repackaging by importers and distributors

Where an importer or distributor packages or repackages an EU fertilising product and is not considered a manufacturer by virtue of pursuant to Article 10, he or she shall

- 1. ensure that the packaging bears his or her name, registered trade name or registered trade mark and postal address preceded by the words ‘packaged by’ or ‘repackaged by’; and**
- 2. keep a specimen of the original information referred to in Article 6(7) at the disposal of the market surveillance authorities for 5 years after having made the EU fertilising product available on the market.**

Article 11

Identification of economic operators

1. Economic operators shall, on request, identify the following to the market surveillance authorities:
 - (a) any economic operator who has supplied them with a ~~CE~~-marked EU fertilising product;
 - (b) any economic operator to whom they have supplied a ~~CE~~-marked EU fertilising product.
2. The economic operators shall be able to present the information referred to in the first paragraph for ~~10~~ 5 years after they have been supplied with the ~~CE~~-marked EU fertilising product and for ~~10~~ 5 years after they have supplied the ~~CE~~-marked EU fertilising product.

CHAPTER 3

CONFORMITY OF ~~CE MARKED~~ EU FERTILISING PRODUCTS

Article 12

Presumption of conformity

~~Without prejudice to the common specifications referred to in Article 13, CE marked~~ EU fertilising products which are in conformity with harmonised standards or parts thereof, the references of which have been published in the Official Journal of the European Union, shall be presumed to be in conformity with the requirements set out in Annexes I, II and III covered by those standards or parts thereof.

Tests for verifying conformity of EU fertilising products with the requirements set out in Annexes I, II and III shall be performed in a reliable and reproducible manner. Tests which are in conformity with harmonised standards or parts thereof, the references of which have been published in the Official Journal of the European Union, shall be presumed to be reliable and reproducible.

Article 13

Common specifications

Where a requirement set out in Annexes I, II and or III, or a test referred to in Article 12, is not covered by harmonised standards or parts thereof the references of which have been published in the Official Journal of the European Union, or where the Commission has initiated a procedure in accordance with Article 11(5) of Regulation (EU) No 1025/2012 for maintaining with restriction or withdrawing the references to the harmonised standards or parts thereof by which ~~the~~ that requirement or that test is covered, the Commission may adopt implementing acts laying down common specifications **for that requirement or that test,** the compliance with which shall ensure conformity with the requirements set out in Annexes I, II and III covered by those specifications or parts thereof. Those implementing acts shall be adopted in accordance with the examination procedure referred to in Article 41(3).

Article 14

Conformity assessment procedures

1. Conformity assessment of a ~~CE marked~~ **EU** fertilising product with the requirements in this Regulation shall be carried out by ~~applying~~ the **applicable** conformity assessment procedure ~~specified~~ in **accordance with** Annex IV.
2. Records and correspondence relating to conformity assessment procedures shall be drawn up in the official language(s) of the Member State where the notified body carrying out the conformity assessment procedures is established, or in a language accepted by that body.

Article 15

EU declaration of conformity

1. The EU declaration of conformity shall state that the fulfilment of the requirements set out in ~~Annexes I, II and III~~ **this Regulation** has been demonstrated.
2. The EU declaration of conformity shall have the model structure set out in Annex V, shall contain the elements specified in the relevant modules set out in Annex IV and shall be continuously updated. It shall be translated into the language or languages required by the Member State in which the ~~CE marked~~ **EU** fertilising product is placed or made available on the market.

3. Where a ~~CE-marked~~ **EU** fertilising product is subject to more than one Union act requiring an EU declaration of conformity, a single EU declaration of conformity shall be drawn up in respect of all such Union acts. That declaration shall state the Union acts concerned and their publication references. It may be a dossier made up of relevant individual declarations of conformity.
4. By drawing up the EU declaration of conformity, the manufacturer shall assume responsibility for the compliance of the ~~CE-marked~~ **EU** fertilising product with the requirements laid down in this Regulation.

Article 16

General principles of CE marking

The CE marking shall be subject to the general principles set out in Article 30 of Regulation (EC) No 765/2008.

Article 17

Rules and conditions for affixing the CE marking

1. The CE marking shall be affixed visibly, legibly and indelibly to the **packaging of the EU fertilising product or, where the EU fertilising product is supplied without packaging, in a document** accompanying documents and, where the ~~CE-marked~~ **EU** fertilising product is supplied in a packaged form, to the packaging.
2. The CE marking shall be affixed before the ~~CE-marked~~ **EU** fertilising product is placed on the market.

3. The CE marking shall be followed by the identification number of the notified body, **where required by** ~~involved in the conformity assessment referred to in Annex IV, Module D1.~~

The identification number of the notified body shall be affixed by the body itself or, under its instructions, by the manufacturer or his or her authorised representative.

4. Member States shall build upon existing mechanisms to ensure correct application of the regime governing the CE marking and shall take appropriate action in the event of improper use of that marking.

Article 18

End-of-waste status

Where a material that was waste has undergone a recovery operation in accordance with this Regulation and a compliant EU fertilising product contains or consists of that material, the material shall be considered to comply with the conditions laid down in Article 6(1) of Directive 2008/98/EC and shall, therefore, be considered as having ceased to be waste from the moment the EU declaration of conformity is drawn up.

~~A CE-marked EU fertilising product that has undergone a recovery operation and complies with the requirements laid down in this Regulation shall be considered to comply with the conditions laid down in Article 6(1) of Directive 2008/98/EC and shall, therefore, be considered as having ceased to be waste.~~

CHAPTER 4

NOTIFICATION OF CONFORMITY ASSESSMENT BODIES

Article 19

Notification

Member States shall notify the Commission and the other Member States of bodies authorised to carry out third-party conformity assessment tasks under this Regulation.

Article 20

Notifying authorities

1. Member States shall designate a notifying authority that shall be responsible for setting up and carrying out the necessary procedures for the assessment and notification of conformity assessment bodies and the monitoring of notified bodies, including compliance with Article 25.
2. Member States may decide that the assessment and monitoring referred to in paragraph 1 shall be carried out by a national accreditation body within the meaning of and in accordance with Regulation (EC) No 765/2008.
3. Where the notifying authority delegates or otherwise entrusts the assessment, notification or monitoring referred to in paragraph 1 to a body which is not a governmental entity, that body shall be a legal entity and shall comply *mutatis mutandis* with the requirements laid down in Article 21. In addition it shall have arrangements to cover liabilities arising out of its activities.
4. The notifying authority shall take full responsibility for the tasks performed by the body referred to in paragraph 3.

Article 21

Requirements relating to notifying authorities

1. A notifying authority shall be established in such a way that no conflict of interest with conformity assessment bodies occurs.
2. A notifying authority shall be organised and operated so as to safeguard the objectivity and impartiality of its activities.
3. A notifying authority shall be organised in such a way that each decision relating to notification of a conformity assessment body is taken by competent persons different from those who carried out the assessment.
4. A notifying authority shall not offer or provide any activities that conformity assessment bodies or consultancy services perform on a commercial or competitive basis.
5. A notifying authority shall safeguard the confidentiality of the information it obtains.
6. A notifying authority shall have a sufficient number of competent personnel at its disposal for the proper performance of its tasks.

Article 22

Information obligation on notifying authorities

Member States shall inform the Commission of their procedures for the assessment and notification of conformity assessment bodies and the monitoring of notified bodies, and of any changes thereto.

The Commission shall make that information publicly available.

Article 23

Requirements relating to notified bodies

1. For the purposes of notification, a conformity assessment body shall meet the requirements laid down in paragraphs 2 to 11.
2. A conformity assessment body shall be established under the national law of a Member State and have legal personality.
3. A conformity assessment body shall be a third-party body independent of the organisation or the ~~CE marked~~ EU fertilising products it assesses.

~~A body belonging to a business association or professional federation representing undertakings involved in the design, manufacturing, provision, or use of CE marked EU fertilising products which it assesses, may, on condition that its independence and the absence of any conflict of interest are demonstrated, be considered such a body.~~

4. A conformity assessment body, its top level management and the personnel responsible for carrying out the conformity assessment tasks shall not be the designer, manufacturer, supplier, purchaser, owner, or user of fertilising products nor the representative of any of those parties. This shall not preclude the use of fertilising products that are necessary for the operations of the conformity assessment body or the use of fertilising products for personal purposes.

A conformity assessment body, its top level management and the personnel responsible for carrying out the conformity assessment tasks shall not be directly involved in the design, manufacture, marketing, or use of fertilising products or represent the parties engaged in those activities. They shall not engage in any activity that may conflict with their independence of judgement or integrity in relation to conformity assessment activities for which they are notified. This shall in particular apply to consultancy services.

Conformity assessment bodies shall ensure that the activities of their subsidiaries or subcontractors do not affect the confidentiality, objectivity or impartiality of their conformity assessment activities.

5. Conformity assessment bodies and their personnel shall carry out the conformity assessment activities with the highest degree of professional integrity and the requisite technical competence in the specific field and shall be free from all pressures and inducements, particularly financial, which might influence their judgement or the results of their conformity assessment activities, especially as regards persons or groups of persons with an interest in the results of those activities.

6. A conformity assessment body shall be capable of carrying out all the conformity assessment tasks assigned to it by Annex IV and in relation to which it has been notified, whether those tasks are carried out by the conformity assessment body itself or on its behalf and under its responsibility.

At all times and for each conformity assessment procedure and each kind or category of ~~CE~~ ~~marked~~ EU fertilising products in relation to which it has been notified, a conformity assessment body shall have at its disposal the necessary:

- (a) personnel with technical knowledge and sufficient and appropriate experience to perform the conformity assessment tasks;
- (b) descriptions of procedures in accordance with which conformity assessment is carried out, ensuring the transparency and the ability of reproduction of those procedures. It shall have appropriate policies and procedures in place that distinguish between tasks it carries out as a notified body and other activities;
- (c) procedures for the performance of activities which take due account of the size of an undertaking, the sector in which it operates, its structure, the degree of complexity of the product technology in question and the mass or serial nature of the production process.

A conformity assessment body shall have the means necessary to perform the technical and administrative tasks connected with the conformity assessment activities in an appropriate manner and shall have access to all necessary equipment or facilities.

7. The personnel responsible for carrying out the conformity assessment tasks shall have the following:
- (a) sound technical and vocational training covering all the conformity assessment activities in relation to which the conformity assessment body has been notified;
 - (b) satisfactory knowledge of the requirements of the assessments they carry out and adequate authority to carry out those assessments;
 - (c) appropriate knowledge and understanding of the requirements set out in Annex I, Annex II and Annex III, of the applicable harmonised standards **referred to in Article 12 and common specifications referred to in Article 13** and of the relevant provisions of Union harmonisation legislation and of national legislation;
 - (d) the ability to draw up certificates, records and reports demonstrating that assessments have been carried out.
8. The impartiality of the conformity assessment bodies, their top level management and of the personnel responsible for carrying out the conformity assessment tasks shall be guaranteed.

The remuneration of the top level management and personnel responsible for carrying out the conformity assessment tasks of a conformity assessment body shall not depend on the number of assessments carried out or on the results of those assessments.

9. Conformity assessment bodies shall take out liability insurance unless liability is assumed by the State in accordance with national law, or the Member State itself is directly responsible for the conformity assessment.
10. The personnel of a conformity assessment body shall observe professional secrecy with regard to all information obtained in carrying out their tasks under Annex IV, except in relation to the competent authorities of the Member State in which its activities are carried out. Proprietary rights shall be protected.
11. Conformity assessment bodies shall participate in, or ensure that their personnel responsible for carrying out the conformity assessment tasks are informed of, the relevant standardisation activities and the activities of the notified body coordination group established under Article 35 and shall apply as general guidance the administrative decisions and documents produced as a result of the work of that group.

Article 24

Presumption of conformity of notified bodies

Where a conformity assessment body demonstrates its conformity with the criteria laid down in the relevant harmonised standards or parts thereof the references of which have been published in the Official Journal of the European Union it shall be presumed to comply with the requirements set out in Article 23 in so far as the applicable harmonised standards cover those requirements.

Article 25

Subsidiaries of and subcontracting by notified bodies

1. Where a notified body subcontracts specific tasks connected with conformity assessment or has recourse to a subsidiary, it shall ensure that the subcontractor or the subsidiary meets the requirements set out in Article 23 and shall inform the notifying authority accordingly.
2. Notified bodies shall take full responsibility for the tasks performed by subcontractors or subsidiaries wherever these are established.
3. Activities may be subcontracted or carried out by a subsidiary only with the agreement of the client.
4. Notified bodies shall keep at the disposal of the notifying authority the relevant documents concerning the assessment of the qualifications of the subcontractor or the subsidiary and the work carried out by them under Annex IV.

Article 26

Application for notification

1. A conformity assessment body shall submit an application for notification to the notifying authority of the Member State in which it is established.
2. The application for notification shall be accompanied by a description of the conformity assessment activities, the conformity assessment module or modules and the ~~CE-marked~~ **EU** fertilising product or products for which that body claims to be competent, as well as by an accreditation certificate issued by a national accreditation body attesting that the conformity assessment body fulfils the requirements laid down in Article 23.

Article 27

Notification procedure

1. Notifying authorities may notify only conformity assessment bodies which have satisfied the requirements laid down in Article 23.
2. They shall notify the Commission and the other Member States using the electronic notification tool developed and managed by the Commission.
3. The notification shall include full details of the conformity assessment activities, the conformity assessment module or modules and ~~CE-marked~~ **EU** fertilising product or products concerned and the accreditation certificate referred to in Article 26(2).
4. The body concerned may perform the activities of a notified body only where no objections are raised by the Commission or the other Member States within two weeks of a notification.

Only such a body shall be considered a notified body for the purposes of this Regulation.

5. The notifying authority shall notify the Commission and the other Member States of any subsequent relevant changes to the notification.

Article 28

Identification numbers and lists of notified bodies

1. The Commission shall assign an identification number to a notified body.

It shall assign a single such number even where the body is notified under several Union acts.

2. The Commission shall make publicly available the list of the bodies notified under this Regulation, including the identification numbers that have been assigned to them and the activities for which they have been notified.

The Commission shall ensure that the list is kept up to date.

Article 29

Changes to notifications

1. Where a notifying authority has ascertained or has been informed that a notified body no longer meets the requirements laid down in Article 23 or that it is failing to fulfil its obligations, the notifying authority shall restrict, suspend or withdraw notification as appropriate, depending on the seriousness of the failure to meet those requirements or fulfil those obligations. It shall immediately inform the Commission and the other Member States accordingly.

2. In the event of restriction, suspension or withdrawal of notification, or where the notified body has ceased its activity, the notifying Member State shall take appropriate steps to ensure that the files of that body are either processed by another notified body or kept available for the responsible notifying and market surveillance authorities at their request.

Article 30

Challenge of the competence of notified bodies

1. The Commission shall investigate all cases where it doubts, or doubt is brought to its attention regarding, the competence of a notified body or the continued fulfilment by a notified body of the requirements and responsibilities to which it is subject.
2. The notifying Member State shall provide the Commission, on request, with all information relating to the basis for the notification or the maintenance of the competence of the notified body concerned.
3. The Commission shall ensure that all sensitive information obtained in the course of its investigations is treated confidentially.
4. Where the Commission ascertains that a notified body does not meet or no longer meets the requirements for its notification, it shall adopt an implementing act requiring the notifying Member State to take the necessary corrective measures, including withdrawal of notification if necessary.

That implementing act shall be adopted in accordance with the advisory procedure referred to in Article 41(2).

Article 31

Operational obligations of notified bodies

1. Notified bodies shall carry out conformity assessments in accordance with the conformity assessment procedures provided for in Annex IV.
2. Conformity assessments shall be carried out in a proportionate manner, avoiding unnecessary burdens for economic operators. Notified bodies shall perform their activities taking due account of the size of an undertaking, the sector in which it operates, its structure, the degree of complexity of the product technology in question and the mass or serial nature of the production process.

In so doing they shall nevertheless respect the degree of rigour and the level of protection required for the compliance of the ~~CE-marked~~ **EU** fertilising product with this Regulation.

3. Where a notified body finds that the requirements set out in Annex I, Annex II or Annex III, or corresponding harmonised standards, common specifications referred to in Article 13 or other technical specifications, have not been met by a manufacturer, it shall require that manufacturer to take appropriate corrective measures and shall not issue a certificate **or approval decision.**
4. Where, in the course of the monitoring of conformity following the issue of a certificate **or approval decision,** a notified body finds that a ~~CE-marked~~ **EU** fertilising product no longer complies, it shall require the manufacturer to take appropriate corrective measures and shall suspend or withdraw the certificate **or approval decision,** if necessary.
5. Where corrective measures are not taken or do not have the required effect, the notified body shall restrict, suspend or withdraw any certificates **or approval decisions,** as appropriate.

Article 32

Appeal against decisions of notified bodies

Member States shall ensure that an appeal procedure against decisions of the notified bodies is available.

Article 33

Information obligation on notified bodies

1. Notified bodies shall inform the notifying authority of the following:
 - (a) any refusal, restriction, suspension or withdrawal of a certificate **or approval decision**;
 - (b) any circumstances affecting the scope of or conditions for notification;
 - (c) any request for information which they have received from market surveillance authorities regarding conformity assessment activities;
 - (d) on request, conformity assessment activities performed within the scope of their notification and any other activity performed, including cross-border activities and subcontracting.
2. Notified bodies shall provide the other bodies notified under this Regulation carrying out similar conformity assessment activities covering the same ~~CE marked~~ **EU** fertilising products with relevant information on issues relating to negative and, on request, positive conformity assessment results.

Article 34

Exchange of experience

The Commission shall provide for the organisation of exchange of experience between the Member States' national authorities responsible for notification policy.

Article 35

Coordination of notified bodies

The Commission shall ensure that appropriate coordination and cooperation between bodies notified under this Regulation are put in place and properly operated in the form of a sectoral group of notified bodies.

Notified bodies shall ~~Member States shall ensure that the bodies notified by them~~ participate in the work of that group, directly or by means of designated representatives.

CHAPTER 5

UNION MARKET SURVEILLANCE, CONTROL OF ~~CE-MARKED~~EU FERTILISING PRODUCTS ENTERING THE UNION MARKET AND UNION SAFEGUARD PROCEDURE

Article 36

Union market surveillance and control of ~~CE-marked~~EU fertilising products entering the Union
market

Articles 16 to 29 of Regulation (EC) No 765/2008 shall apply to ~~CE-marked~~EU fertilising
products.

Article 37

Procedure **at national level** for dealing with ~~CE marked~~ **EU** fertilising products presenting a risk at national level

1. Where the market surveillance authorities of one Member State have sufficient reason to believe that a ~~CE marked~~ **EU** fertilising product presents an unacceptable risk to human, animal or plant health, to safety or to the environment, they shall carry out an evaluation in relation to the fertilising product concerned covering **all relevant** ~~the~~ requirements laid down in this Regulation. The relevant economic operators shall cooperate as necessary with the market surveillance authorities for that purpose.

Where, in the course of the evaluation **referred to in the first subparagraph**, the market surveillance authorities find that the ~~CE marked~~ **EU** fertilising product does not comply with the requirements laid down in this Regulation, they shall without delay require the economic operator to take all appropriate corrective actions within a reasonable period to bring the fertilising product into compliance with those requirements, to withdraw the fertilising product from the market, **or** to recall it, ~~or, to remove the CE marking.~~

Market surveillance authorities' obligations in this respect shall be without prejudice to Member States' possibility to regulate fertilising products which are not CE marked when made available on the market.

The market surveillance authorities shall inform the relevant notified body accordingly.

Article 21 of Regulation (EC) No 765/2008 shall apply to the measures referred to in the second subparagraph.

2. Where the market surveillance authorities consider that non-compliance is not restricted to their national territory, they shall inform the Commission and the other Member States of the results of the evaluation and of the actions which they have required the economic operator to take.
3. The economic operator shall ensure that all appropriate corrective action is taken in respect of all the ~~CE~~-marked EU fertilising products concerned that it has made available on the market throughout the Union.
4. Where the relevant economic operator does not take adequate corrective action within the period referred to in the second subparagraph of paragraph 1, the market surveillance authorities shall take all appropriate provisional measures to prohibit or restrict the ~~CE~~ marked-EU fertilising product being made available on their national market, to withdraw the fertilising product from that market or to recall it.

The market surveillance authorities shall inform the Commission and the other Member States, without delay, of those measures.

5. The information referred to in the second subparagraph of paragraph 4 shall include all available details, in particular the data necessary for the identification of the non-compliant ~~CE marked~~ EU fertilising product, the origin of that fertilising product, the nature of the non-compliance alleged and the risk involved, the nature and duration of the national measures taken and the arguments put forward by the relevant economic operator. In particular, the market surveillance authorities shall indicate whether the non-compliance is due to either of the following:

- (a) failure of the ~~CE marked~~ EU fertilising product to meet the requirements set out in Annexes I, II or III
- (b) shortcomings in the harmonised standards referred to in Article 12 ~~conferring a presumption of conformity~~;

(ba) shortcomings in the common specifications referred to in Article 13

6. Member States other than the Member State initiating the procedure under this Article shall without delay inform the Commission and the other Member States of any measures adopted and of any additional information at their disposal relating to the non-compliance of the ~~CE marked~~ EU fertilising product concerned, and, in the event of disagreement with the adopted national measure, of their objections.

7. Where, within three months of receipt of the information referred to in the second subparagraph of paragraph 4, no objection has been raised by either a Member State or the Commission in respect of a provisional measure taken by a Member State, that measure shall be deemed justified.

8. Member States shall ensure that appropriate restrictive measures, such as withdrawal, are taken without delay in respect of the ~~CE marked~~ EU fertilising product concerned.

Article 38

Union safeguard procedure

1. Where, on completion of the procedure set out in Article 37(3) and (4), objections are raised against a measure taken by a Member State, or where the Commission considers a national measure to be contrary to Union legislation, the Commission shall without delay enter into consultation with the Member States and the relevant economic operator or operators and shall evaluate the national measure. On the basis of the results of that evaluation, the Commission shall adopt an implementing act in the form of a decision determining whether the national measure is justified or not.

If the national measure is considered justified, the decision shall order all Member States to take the necessary measures to ensure that the non-compliant ~~CE-marked~~ **EU** fertilising product is withdrawn from their market, and to inform the Commission accordingly.

If the national measure is considered unjustified, the decision shall order the Member State concerned to withdraw that measure.

The Commission shall address its decision to all Member States and shall immediately communicate it to them and the relevant economic operator or operators.

2. Where the national measure is considered justified and the non-compliance of the ~~CE-marked~~ **EU** fertilising product is attributed to shortcomings in the harmonised standards referred to in point (b) of Article 37(5), the Commission shall apply the procedure provided for in Article 11 of Regulation (EU) No 1025/2012.

- 2a. Where the national measure is considered justified and the non-compliance of the EU fertilising product is attributed to shortcomings in the common specifications referred to in point (c) of Article 37(5), the Commission shall, without delay, adopt an implementing act amending or repealing the common specification concerned. The implementing act shall be adopted in accordance with the examination procedure referred to in Article 41(3).**

Article 39

Compliant ~~CE~~-marked EU fertilising products which present a risk

1. Where, having carried out an evaluation under Article 37(1), a Member State finds that although a ~~CE~~-marked EU fertilising product is in compliance with this Regulation it presents an unacceptable risk to human, animal or plant health, to safety or to the environment, it shall require the relevant economic operator to take all appropriate measures within a reasonable period to ensure that the fertilising product concerned, when placed on the market, no longer presents that risk, to withdraw the fertilising product from the market or to recall it.
2. The economic operator shall ensure that corrective action is taken in respect of all the ~~CE~~-marked EU fertilising products concerned that he or she has made available on the market throughout the Union.
3. The Member State shall immediately inform the Commission and the other Member States. That information shall include all available details, in particular the data necessary for the identification of the ~~CE~~-marked EU fertilising product concerned, the origin and the supply chain of that fertilising product, the nature of the risk involved and the nature and duration of the national measures taken.

4. The Commission shall without delay enter into consultation with the Member States and the relevant economic operator or operators and shall evaluate the national measures taken. On the basis of the results of that evaluation, the Commission shall adopt an implementing act in the form of a decision determining whether the national measure is justified or not, and where necessary, ordering appropriate measures.

Those implementing acts shall be adopted in accordance with the examination procedure referred to in Article 41(3).

On duly justified imperative grounds of urgency relating to the protection of human, animal or plant health, safety or the environment, the Commission shall adopt immediately applicable implementing acts in accordance with the procedure referred to in Article 41(4).

5. The Commission shall address its decision to all Member States and shall immediately communicate it to them and the relevant economic operator or operators.

Article 40

Formal non-compliance

1. Without prejudice to Article 37, where a Member State makes one of the following findings on a ~~CE marked~~ **EU** fertilising product, it shall require the relevant economic operator to put an end to the non-compliance concerned:
 - (a) the CE marking has been affixed in violation of Article 30 of Regulation (EC) No 765/2008 or of Article 17 of this Regulation;
 - (b) the identification number of the notified body has been affixed in violation of Article 17 or has not been affixed, where required by Article 17;
 - ~~(c) the EU declaration of conformity does not accompany the CE marked **EU** fertilising product;~~
 - (ca) the EU declaration of conformity has not been drawn up**
 - (d) the EU declaration of conformity has not been drawn up correctly;
 - (e) **the** technical documentation is either not available or not complete;
 - (f) the information referred to in Article 6(6) or Article 8(3) is absent, false or incomplete;
 - (g) any other administrative requirement provided for in Article 6 or Article 8 is not fulfilled.

2. Where the non-compliance referred to in paragraph 1 persists, the Member State concerned shall take all appropriate measures to restrict or prohibit the ~~CE marked~~ EU fertilising product being made available on the market or ensure that it is recalled or withdrawn from the market ~~or, that the CE marking is removed.~~

Member States' obligations in this respect shall be without prejudice to their possibility to regulate fertilising products which are not CE marked when made available on the market.

CHAPTER 6

COMMITTEE AND DELEGATED ACTS

Article 41

Committee procedure

1. The Commission shall be assisted by the Committee on Fertilising products. That committee shall be a committee within the meaning of Regulation (EU) No 182/2011.
2. Where reference is made to this paragraph, Article 4 of Regulation (EU) No 182/2011 shall apply.
3. Where reference is made to this paragraph, Article 5 of Regulation (EU) No 182/2011 shall apply.
4. Where reference is made to this paragraph, Article 8 of Regulation (EU) No 182/2011, in conjunction with Article 5 thereof, shall apply.

Article 42

Amendments of Annexes

1. The Commission shall be empowered to adopt delegated acts in accordance with Article 43 to amend ~~Annexes I, with the exception of cadmium (Cd) limit values, and Annexes II, III and IV~~ **Annexes II to IV** for the purposes of adapting them to technical progress **established after the adoption of this regulation**, in particular in the field of fertilising product production from animal by-products, of waste recovery, in the agricultural sector and the agro-food industry, and for facilitating internal market access and free movement for EU fertilising products,
 - (a) which are likely to be subject of significant trade on the internal market, and
 - (b) for which there is scientific evidence that they do not present a risk, and that they are sufficiently effective.

Those delegated acts may also introduce contaminant limits in Annex I which are necessary as a consequence of the addition of component materials in Annex II.

2. Where the Commission amends Annex II in order to add new micro-organisms **or strains of microorganisms** to the component material category for such organisms pursuant to paragraph 1, it shall do so, **after having verified which strains of the additional microorganism are fulfilling the provisions of paragraph 1 (b)**, on the basis of the following data:
- (a) name of the micro-organism;
 - (b) taxonomic classification of the micro-organism; **genus, species, strain and procurement method;**
 - (c) ~~historical data of~~ **scientific literature reporting about** safe production, **conservation** and use of the micro-organism
 - (d) taxonomic relation to micro-organism species fulfilling the requirements for a Qualified Presumption of Safety as established by the European Food Safety **Authority** Agency;
 - ~~(e) information on residue levels of toxins;~~
 - (f) information on the production process; and
 - (g) information on the identity **and residue levels** of residual intermediates, **toxins** or microbial metabolites in the component material;
 - (ga) natural occurrence, survival and mobility in the environment.**

3. When adopting delegated acts in accordance with paragraph 1, the Commission may amend the component material categories set out in Annex II in order to add **products derived from animal by-products within the meaning of Regulation (EC) No 1069/2009 only where an end point in the manufacturing chain has been determined for such products in accordance with the procedures laid down in that Regulation.**

3a. When adopting delegated acts in accordance with paragraph 1, the Commission may amend the component material categories set out in Annex II in order to include materials that have ceased to be waste following a recovery operation only if recovery rules in that Annex, adopted no later than the inclusion, ensure that the materials comply with the conditions laid down in Article 6(1) of Directive 2008/98/EC.

4. The Commission shall also be empowered to adopt delegated acts in accordance with Article 43 to amend Annexes I, **with the exception of cadmium (Cd) limit values, and Annexes II, III and** ~~to~~ IV in the light of new scientific evidence. The Commission shall use this empowerment where, based on a risk assessment, an amendment proves necessary to ensure that any ~~CE marked~~ **EU** fertilising product complying with the requirements of this Regulation does not, under normal conditions of use, present an ~~unacceptable risk to human, animal, or plant health, to safety or to the environment.~~

4a. **By (Publication office please insert the date occurring five years after the date of entry-into-force of this Regulation) the Commission shall adopt delegated acts in accordance with Article 43 to supplement point 2 of CMC 10 in Annex II in the light of the latest scientific evidence by laying down the exact biodegradability criteria and the testing method for biodegradation that ensure that as a result of physical and biological decomposition polymers ultimately decompose into carbon dioxide (CO₂), biomass and water. Those criteria shall ensure that the use of polymers does not lead to accumulation of plastics in the environment.**

4b. Prior to the adoption of delegated acts introducing new contaminant limits in Annex I in accordance with paragraph 1, the Commission shall request the scientific advice of the European Food Safety Authority provided under Article 22 of Regulation (EC) No 178/2002 of the European Parliament and of the Council of 28 January 2002 laying down the general principles and requirements of food law, establishing the European Food Safety Authority and laying down procedures in matters of food safety.

Article 42a

Separate delegated acts for separate Component Material Categories

When exercising its power to adopt delegated acts pursuant to Article 42, the Commission shall adopt a separate delegated act in respect of each Component Material Category in Annex II, including the introduction of any contaminant limits in Annex I which are necessary as a consequence of the addition of component materials in Annex II.

Article 43

Exercise of the delegation

1. The power to adopt delegated acts is conferred on the Commission subject to the conditions laid down in this Article.
2. The power to adopt delegated acts referred to in Article 42 shall be conferred on the Commission for **a period of** five years from [Publications office, please insert the date of entry into force of this Regulation]. The Commission shall draw up a report in respect of the delegation of power not later than nine months before the end of the five-year period. The delegation of power shall be tacitly extended for periods of an identical duration, unless the European Parliament or the Council opposes such extension not later than three months before the end of each period.

3. The delegation of power referred to in Article 42 may be revoked at any time by the European Parliament or by the Council. A decision to revoke shall put an end to the delegation of the power specified in that decision. It shall take effect the day following the publication of the decision in the Official Journal of the European Union or at a later date specified therein. It shall not affect the validity of any delegated acts already in force.

3a. Before adopting a delegated act, the Commission shall consult experts designated by each Member State in accordance with the principles laid down in the Interinstitutional Agreement on Better Law-Making of 13 April 2016.

4. As soon as it adopts a delegated act, the Commission shall notify it simultaneously to the European Parliament and to the Council.
5. A delegated act adopted pursuant to Article 42 shall enter into force only if no objection has been expressed either by the European Parliament or the Council within a period of **three** ~~two~~ months of notification of that act to the European Parliament and the Council or if, before the expiry of that period, the European Parliament and the Council have both informed the Commission that they will not object. That period shall be extended by **three** ~~two~~ months at the initiative of the European Parliament or of the Council.

CHAPTER 7

TRANSITIONAL AND FINAL PROVISIONS

Article 44

Penalties

Member States shall lay down rules on penalties applicable to infringements **by economic operators** of this Regulation and shall take all measures necessary to ensure that they are implemented. The penalties provided for shall be effective, proportionate and dissuasive. Member States shall, without delay, notify the Commission of those rules and of those measures and shall notify it, without delay, of any subsequent amendment affecting them.

Article 45

Amendments to Regulation (EC) No 1069/2009

In Regulation (EC) No 1069/2009, Article 5 is amended as follows:

- (1) in paragraph 2, the first subparagraph is replaced by the following:

"For derived products referred to in Articles 32, 35 and 36 which no longer pose any significant risk to public or animal health, an end point in the manufacturing chain may be determined, beyond which they are no longer subject to the requirements of this Regulation.";

- (2) paragraph 3 is replaced by the following:

"3. In the event of risks to public or animal health, Articles 53 and 54 of Regulation (EC) No 178/2002 concerning emergency health measures shall apply *mutatis mutandis* to the derived products referred to in Articles 32, 33 and 36 of this Regulation."

Article 46

Amendments to Regulation (EC) No 1107/2009

Regulation (EC) No 1107/2009 is amended as follows:

(1) Article 2(1) (b) is replaced by the following:

"(b) influencing the life processes of plants, such as substances influencing their growth, other than as a nutrient or a plant biostimulant;"

(2) in Article 3, the following point is added:

"34. "plant biostimulant" means a product stimulating plant nutrition processes independently of the product's nutrient content with the sole aim of improving one or more of the following characteristics of the plant:

- (a) nutrient use efficiency;
- (b) tolerance to abiotic stress;
- (c) ~~crop~~ quality traits."

(2a) in Article 80, the following new paragraph is added:

"8. To a product which was granted an authorisation under Article 32(1) based on an application submitted before [Please insert the date of entry into force of the Regulation on the making available on the market of EU fertilising products], and which after that date falls under the definition in point 34 of Article 3, this Regulation shall continue to apply for the duration provided in the authorisation."

Article 47

Repeal of Regulation (EC) No 2003/2003

Regulation (EC) No 2003/2003 is repealed with effect from **[Publications office, please insert the date 3 years after the date of entry into force]** ~~the date referred to in the second paragraph of Article 49.~~

References to the repealed Regulation shall be construed as references to this Regulation.

Article 47a

Review

By [Publication office, please insert the date 16 years after the entry into force of this Regulation], the Commission shall carry out a review of limit values for cadmium content in phosphate fertilisers. This review shall be accompanied, if necessary, by a legislative proposal.

Article 48

Transitional provisions

Member States shall not impede the making available on the market of products which were placed on the market as fertilisers designated "EC fertiliser" in conformity with Regulation (EC) No 2003/2003 before [Publications office, please insert the date **three years after the entry-into-force** of application of this Regulation]. However, Chapter 5 shall apply *mutatis mutandis* to such products.

Article 49

Entry into force and application

This Regulation shall enter into force on the twentieth day following that of its publication in the Official Journal of the European Union.

It shall apply from ~~1 January 2018~~ **[Publications office, please insert the date three years after the date of entry into force of this Regulation], with the exception of:**

(a) Articles 19 to 35, which shall apply from [Publications office, please insert the date nine months after the date of entry into force] and

(b) Articles 13, 41, 42, 43, 45 and 46, which shall apply from [Publications office, please insert the date of entry into force].

This Regulation shall be binding in its entirety and directly applicable in all Member States.

Done at Brussels,

For the European Parliament

For the Council

The President

The President

Product Function Categories ('PFC') of ~~CE~~-marked-EU fertilising products

PART I

DESIGNATION OF PRODUCT FUNCTION CATEGORIES

1. Fertiliser
 - A. Organic fertiliser
 - I. Solid organic fertiliser
 - II. Liquid organic fertiliser
 - B. Organo-mineral fertiliser
 - I. Solid organo-mineral fertiliser
 - II. Liquid organo-mineral fertiliser

C. Inorganic fertiliser

I. Inorganic macronutrient fertiliser

a) Solid inorganic macronutrient fertiliser

i) Straight solid inorganic macronutrient fertiliser

A) Straight solid inorganic macronutrient ammonium nitrate fertiliser of high nitrogen content

ii) Compound solid inorganic macronutrient fertiliser

A) Compound solid inorganic macronutrient ammonium nitrate fertiliser of high nitrogen content

b) Liquid inorganic macronutrient fertiliser

i) Straight liquid inorganic macronutrient fertiliser

ii) Compound liquid inorganic macronutrient fertiliser

II. Inorganic micronutrient fertiliser

a) Straight inorganic micronutrient fertiliser

b) Compound inorganic micronutrient fertiliser

2. **Liming material**
3. Soil improver
 - A. Organic soil improver
 - B. Inorganic soil improver
4. Growing medium
5. ~~Agronomic additive~~
 - ~~A. Inhibitor~~
 - ~~I.A Nitrification inhibitor~~
 - ~~H.B Urease inhibitor~~
 - C. Denitrification inhibitor**
6. Plant biostimulant
 - A. Microbial plant biostimulant
 - B. Non-microbial plant biostimulant
 - ~~I. Organic non-microbial plant biostimulant~~
 - ~~H. Inorganic non-microbial plant biostimulant~~
7. Fertilising product blend

PART II

REQUIREMENTS RELATED TO PRODUCT FUNCTION CATEGORIES

1. This Part sets out the requirements related to the Product Function Categories ('PFC') to which ~~CE marked~~ EU fertilising products shall belong **by virtue of its claimed function**.
2. The requirements laid down in this Annex for a given PFC apply to ~~CE marked~~ EU fertilising products in all subcategories of that PFC.

(2a) The fact that a fertilising product complies with the function described in this Annex for the relevant PFC shall be supported by the product's mode of action, the relative concentration of its various components, or any other relevant parameter.

3. Where compliance with a given requirement (such as absence of a given contaminant) follows certainly and uncontestably from the nature or manufacturing process of a ~~CE marked~~ EU fertilising product, that compliance can be presumed in the conformity assessment without verification (such as testing), at the responsibility of the manufacturer.

4. Where the ~~CE marked~~ **EU** fertilising product contains a substance for which maximum residue limits for food and feed have been established in accordance with

- (a) Council Regulation (EEC) No 315/93¹⁹,
- (b) Regulation (EC) No 396/2005 of the European Parliament and of the Council²⁰,
- (c) Regulation (EC) No 470/2009 of the European Parliament and of the Council²¹ or
- (d) Directive 2002/32/EC of the European Parliament and of the Council²²,

the use of the ~~CE marked~~ **EU** fertilising product as specified in the use instructions must not lead to the exceedance of those limits in food or feed.

¹⁹ Council Regulation (EEC) No 315/93 of 8 February 1993 laying down Community procedures for contaminants in food (OJ L 37, 13.2.1993, p. 1).

²⁰ Regulation (EC) No 396/2005 of the European Parliament and of the Council of 23 February 2005 on maximum residue levels of pesticides in or on food and feed of plant and animal origin and amending Council Directive 91/414/EEC (OJ L 70, 16.3.2005, p. 1).

²¹ Regulation (EC) No 470/2009 of the European Parliament and of the Council of 6 May 2009 laying down Community procedures for the establishment of residue limits of pharmacologically active substances in foodstuffs of animal origin, repealing Council Regulation (EEC) No 2377/90 and amending Directive 2001/82/EC of the European Parliament and of the Council and Regulation (EC) No 726/2004 of the European Parliament and of the Council (OJ L 152, 16.6.2009, p. 11).

²² Directive 2002/32/EC of the European Parliament and of the Council of 7 May 2002 on undesirable substances in animal feed (OJ L 140, 30.5.2002, p. 10).

4a. The requirements in this Annex are expressed in oxidised form for certain nutrients. Where compliance is assessed based on the presence of the nutrient in question in its elemental form, the following conversion factors shall be used:

phosphorus (P) = phosphorus pentoxide (P₂O₅) × 0,436;

potassium (K) = potassium oxide (K₂O) × 0,830;

calcium (Ca) = calcium oxide (CaO) × 0,715;

magnesium (Mg) = magnesium oxide (MgO) × 0,603;

sodium (Na) = sodium oxide (Na₂O) × 0,742;

sulphur (S) = sulphur trioxide (SO₃) × 0,400.

4b. The requirements in this Annex are expressed by reference to organic carbon (C_{org}). Where compliance is assessed based on organic matter the following conversion factor applies:

~~C_{org} = organic matter × 0,5 for PFC 1A and PFC 1B;~~

~~C_{org} = organic matter × 0,56 for PFC 3.~~

4c. Phosphonates shall not be intentionally added to ~~present in~~ any EU fertilising product. Unintentional presence of phosphonates shall not exceed ~~by~~ 0,5% by mass.

PFC 1: FERTILISER

A fertiliser shall be a ~~CE marked~~ EU fertilising product **the function of which is to provide** aimed at ~~providing~~ nutrients to plants **or mushrooms**.

PFC 1(A): Organic fertiliser

1. An organic fertiliser shall contain

- **organic** carbon (**C_{org}**) and
- nutrients

of solely biological origin.

Organic fertiliser may contain leonardite and lignite, but ~~excluding~~ **no other** material which is fossilized or embedded in geological formations.

2. Contaminants must not be present in the ~~CE marked~~ EU fertilising product by more than the following quantities:

- Cadmium (Cd) 1,5 mg/kg dry matter,
- Hexavalent chromium (Cr VI) 2 mg/kg dry matter,
- Mercury (Hg) 1 mg/kg dry matter,
- Nickel (Ni) 50 mg/kg dry matter,
- Lead (Pb) 120 mg/kg dry matter, ~~and~~
- ~~Biuret (C₂H₅N₃O₂)~~ 12 g/kg dry matter.

• Arsenic (As)

40 mg/kg dry matter

Biuret (C₂H₅N₃O₂) must not be present in the EU fertilising product.

2a. Copper (Cu) must not be present in the EU fertilising product by more than 300 mg/kg dry matter, and zinc (Zn) must not be present in the EU fertilising product by more than 800 mg/kg dry matter.

3. Pathogens must not be present in the organic fertiliser in a concentration of more than the respective limits outlined in the table below:

<u>Micro-organisms to be tested</u>	<u>Sampling plans</u>			<u>Limit</u>
	<u>n</u>	<u>c</u>	<u>m</u>	<u>M</u>
<u>Salmonella spp</u>	<u>5</u>	<u>0</u>	<u>0</u>	<u>Absence in 25 g or 25 ml</u>
<u>Escherichia coli</u> <u>or</u> <u>Enterococaceae</u>	<u>5</u>	<u>5</u>	<u>0</u>	<u>1000 in 1g or 1 ml</u>

where n = number of samples to be tested,

c = number of samples where the number of bacteria expressed in CFU may be between m and M,

m= threshold value for the number of bacteria expressed in CFU that is considered satisfactory,

M= maximum value of the number of bacteria expressed in CFU.

In the organic fertiliser:

~~(a) — Absence of Salmonella spp. and **maximum** presence of Escherichia coli and Enterococcaceae shall be **demonstrated in accordance with the standards laid down in Annex XI, chapter I, section 2 (d) of Regulation (EU) No. 142/2011**, absent in a 25 g sample of the CE marked **EU** fertilising product.~~

~~Absence of resistant **Parasites** such as eggs of *Ascaris spp.* and *Toxocara spp.* **must not be present in 100 g or 100 ml of the organic fertiliser shall be demonstrated according to a scientifically accepted method.**~~

~~4. — None of the two following types of bacteria shall be present in the CE marked **EU** fertilising product in a concentration of more than 1000 CFU/g fresh mass:~~

~~(a) — Escherichia coli, or~~

~~(b) — Enterococcaceae.~~

~~This shall be demonstrated by measuring the presence of at least one of those two types of bacteria~~

PFC 1(A)(I): Solid organic fertiliser

1. A solid organic fertiliser **shall be in solid form**, shall contain 40% or more dry matter by mass.
2. **The EU fertilising product shall contain at least one of the following declared nutrients: nitrogen (N), phosphorus pentoxide (P₂O₅) or potassium oxide (K₂O).**

Where the product contains only one declared nutrient, the nutrient shall be present The CE marked **EU** fertilising product shall contain at least one of the following declared nutrients in the **following** minimum quantities stated:

- 2,5% by mass of total nitrogen (N), **or**
- 2% by mass of total phosphorus pentoxide (P₂O₅), or
- 2% by mass of total potassium oxide (K₂O).

Where the product contains more than one nutrient, the following minimum quantities of declared nutrients shall be present:

- **1 % by mass of total nitrogen (N), or**
 - **1% by mass of total phosphorus pentoxide (P₂O₅), or**
 - **1% by mass of total potassium oxide (K₂O); and**
 - **4% by mass of total sum of nutrients.**
3. Organic carbon (C_{org}) shall be present in the CE marked **EU** fertilising product by at least 15% by mass.

PFC 1(A)(II): Liquid organic fertiliser

1. A liquid organic fertiliser **shall be in liquid form.** ~~shall contain less than 40% dry matter.~~
2. **The EU fertilising product shall contain at least one of the following declared nutrients: nitrogen (N), phosphorus pentoxide (P₂O₅) or potassium oxide (K₂O).**

Where the product contains only one declared nutrient, the nutrient shall be present ~~The CE marked EU fertilising product shall contain at least one of the following declared nutrients in the following minimum quantities stated:~~

- 2% by mass of total nitrogen (N), **or**
- 1% by mass of total phosphorus pentoxide (P₂O₅), or
- 2% by mass of total potassium oxide (K₂O).

Where the product contains more than one nutrient, the following minimum quantities of declared nutrients shall be present:

- **1 % by mass of total nitrogen (N), or**
 - **1% by mass of total phosphorus pentoxide (P₂O₅), or**
 - **1% by mass of total potassium oxide (K₂O) and**
 - **3% by mass of total sum of nutrients .**
3. Organic carbon (C_{org}) shall be present in the ~~CE marked~~ **EU** fertilising product by at least 5% by mass.

PFC 1(B): Organo-mineral fertiliser

1. An organo-mineral fertiliser shall be a co-formulation of
 - one or more inorganic fertilisers, as specified in PFC 1(C) below, and
 - **one or more** a materials containing
 - organic carbon (C_{org}) and
 - nutrients

of solely biological origin, **including leonardite and lignite, but** excluding **other** materials which **are** is-fossilized or embedded in geological formations.
2. Where one or more of the inorganic fertilisers in the co-formulation is a straight or compound solid inorganic macronutrient ammonium nitrate fertiliser of high nitrogen content, as specified in PFC 1(C)(I)(a)(i ii)(A), the ~~CE~~-marked **EU** fertilising product shall not contain ~~15,75~~ **10** % or more by mass of nitrogen (N) as a result of ammonium nitrate (NH_4NO_3).

3. Contaminants must not be present in the ~~CE~~-marked EU fertilising product by more than the following quantities:

(a) Cadmium (Cd)

(1) Where the ~~CE~~-marked EU fertilising product has a total phosphorus (P) content of less than 5 % phosphorus pentoxide (P₂O₅)-equivalent by mass: 3 mg/kg dry matter, or

(2) Where the ~~CE~~-marked EU fertilising product has a total phosphorus (P) content of 5 % phosphorus pentoxide (P₂O₅)-equivalent or more by mass ('phosphate fertiliser'):

- As of [Publications office, please insert the date **eight years after the entry-into-force** of application of this Regulation]: 60 mg/kg phosphorus pentoxide (P₂O₅),
- ~~As of [Publications office, please insert the date **five years after the entry-into-force** occurring three years after the date of application of this Regulation]: 40 mg/kg phosphorus pentoxide (P₂O₅), and~~
- ~~As of [Publications office, please insert the date **fourteen years after the entry-into-force** occurring twelve years after the date of application of this Regulation]: 20 mg/kg phosphorus pentoxide (P₂O₅),~~

(b) Hexavalent chromium (Cr VI)	2 mg/kg dry matter,
(c) Mercury (Hg)	1 mg/kg dry matter,
(d) Nickel (Ni)	50 mg/kg dry matter, and
(e) Lead (Pb)	120 mg/kg dry matter.
<u>(ea) Arsenic (As)</u>	<u>40 mg/kg dry matter</u>
<u>(ed) Biuret (C₂H₅N₃O₂)</u>	<u>12 g/kg dry matter</u>

3a. Copper (Cu) must not be present in the EU fertilising product by more than 600 mg/kg dry matter, and Zinc (Zn) must not be present in the EU fertilising product by more than 1500 mg/kg dry matter. However, these limit values shall not apply where the copper or zinc has been intentionally added to the fertilising product for the purpose of correcting the soil micronutrient deficiency and is declared in accordance with Annex III.

4. Pathogens must not be present in the organo-mineral fertiliser in a concentration of more than the respective limits outlined in the table below

<u>Micro-organisms to be tested</u>	<u>Sampling plans</u>			<u>Limit</u>
	<u>n</u>	<u>c</u>	<u>m</u>	<u>M</u>
<u>Salmonella spp</u>	<u>5</u>	<u>0</u>	<u>0</u>	<u>Absence in 25 g or 25 ml</u>
<u>Escherichia coli</u> <u>or</u> <u>Enterococcaceae</u>	<u>5</u>	<u>5</u>	<u>0</u>	<u>1000 in 1g or 1 ml</u>

where n = number of samples to be tested,

c = number of samples where the number of bacteria expressed in CFU may be between m and M,

m= threshold value for the number of bacteria expressed in CFU that is considered satisfactory,

M= maximum value of the number of bacteria expressed in CFU.

In the organo-mineral fertiliser:

~~(a) Absence of~~ *Salmonella* spp. and ~~maximum~~ presence of *Escherichia coli* and *Enterococcaceae* shall be ~~demonstrated in accordance with the standards laid down in Annex XI, chapter I, section 2 (d) of Regulation (EU) No. 142/2011.~~ absent in a 25 g sample of the CE marked EU fertilising product.

Absence of resistant ~~Parasites~~ such as eggs of ~~*Ascaris spp.* and *Toxocara spp.*~~ **must not be present in the organo-mineral fertiliser shall be demonstrated according to a scientifically accepted method.**

5. ~~None of the two following types of bacteria shall be present in the CE marked EU fertilising product in a concentration of more than 1000 CFU/g fresh mass:~~

~~(a) *Escherichia coli*, or~~

~~(b) *Enterococcaceae*.~~

~~This shall be demonstrated by measuring the presence of at least one of those two types of bacteria.~~

PFC 1(B)(I): Solid organo-mineral fertiliser

1. A solid organo-mineral fertiliser **shall be in solid form** shall contain 60% or more dry matter by mass.
2. **The EU fertilising product shall contain at least one of the following declared nutrients: nitrogen (N), phosphorus pentoxide (P₂O₅) or potassium oxide (K₂O).**

Where the product contains only one declared nutrient, the nutrient shall be present The CE marked EU fertilising product shall contain at least one of the following declared nutrients in the **following** minimum quantities stated:

- 2,5 % by mass of total nitrogen (N), out of which 1 % by mass of the CE marked EU fertilising product shall be organic nitrogen (N), or
- 2 % by mass of total phosphorus pentoxide (P₂O₅), or
- 2 % by mass of total potassium oxide (K₂O).

Where the product contains more than one nutrient, the following minimum quantities of declared nutrients shall be present:

- **2 % by mass of total nitrogen (N), out of which 0,5 % by mass of the EU fertilising product shall be organic nitrogen (N), or**
 - **2% by mass of total phosphorus pentoxide (P₂O₅), or**
 - **2% by mass of total potassium oxide (K₂O) and**
 - **8% by mass of total sum of nutrients.**
3. Organic carbon (C_{org}) shall be present in the CE marked EU fertilising product by at least 7.5 % by mass.
 4. In the CE marked EU fertilising product, each **physical** unit shall contain the organic matter and the nutrients in their declared content.

PFC 1(B)(II): Liquid organo-mineral fertiliser

1. A liquid organo-mineral fertiliser **shall be in liquid form** ~~shall contain less than 60 % dry matter by mass.~~
2. **The EU fertilising product shall contain at least one of the following declared nutrients:**
 - **nitrogen (N), or**
 - **phosphorus pentoxide (P₂O₅): or**
 - **potassium oxide (K₂O).**

Where the product contains only one declared nutrient, the nutrient shall be present ~~The CE-marked EU fertilising product shall contain at least one of the following declared nutrients in the **following** minimum quantities stated:~~

- 2 % by mass of total nitrogen (N), out of which 0,5 % by mass of the ~~CE-marked~~ **EU** fertilising product shall be organic nitrogen (N), or
- 2 % by mass of total phosphorus pentoxide (P₂O₅), or
- 2 % by mass of total potassium oxide (K₂O).

Where the product contains more than one nutrient, the following minimum quantities of declared nutrients shall be present:

- **2 % by mass of total nitrogen (N), out of which 0,5 % by mass of the EU fertilising product shall be organic nitrogen (N), or**
- **2% by mass of total phosphorus pentoxide (P₂O₅), or**
- **2% by mass of total potassium oxide (K₂O) and**
- **6% by mass of total sum of nutrients .**

3. Organic carbon (C_{org}) shall be present in the ~~CE marked~~ **EU** fertilising product by at least 3 % by mass.

PFC 1(C): Inorganic fertiliser

1. An inorganic fertiliser shall be a fertiliser **containing or releasing nutrients in a mineral form**, other than an organic or organo-mineral fertiliser.
- 2. In addition to the requirements of either PFC 1 (C) I or PFC 1 (C) II below; an inorganic fertiliser which contains more than 1 % by mass of organic carbon (C_{org}), other than organic carbon (C_{org}) from**
- **chelating or complexing agents referred to in point 2a of CMC 1, from**
 - **nitrification inhibitors, urease inhibitors or denitrification inhibitors referred to in point 2b of CMC 1, from**
 - **coating agents referred to in point 1(a) of CMC 10, from**
 - **urea, or from**
 - **calcium cyanamide,**
- shall meet the following requirements:**

Pathogens must not be present in the organic fertiliser in a concentration of more than the respective limits outlined in the table below:

<u>Micro-organisms to be tested</u>	<u>Sampling plans</u>			<u>Limit</u>
	<u>n</u>	<u>c</u>	<u>m</u>	<u>M</u>
<u>Salmonella spp</u>	<u>5</u>	<u>0</u>	<u>0</u>	<u>Absence in 25 g or 25 ml</u>
<u>Escherichia coli</u> <u>or</u> <u>Enterococcaceae</u>	<u>5</u>	<u>5</u>	<u>0</u>	<u>1000 in 1g or 1 ml</u>

where n = number of samples to be tested,

c = number of samples where the number of bacteria expressed in CFU may be between m and M,

m= threshold value for the number of bacteria expressed in CFU that is considered satisfactory,

M= maximum value of the number of bacteria expressed in CFU.

Parasites *Ascaris spp.* and *Toxocara spp.* must not be present in 100g or 100ml of the organo-mineral fertiliser.

PFC 1(C)(I): Inorganic macronutrient fertiliser

1. An inorganic macronutrient fertiliser shall be aimed at providing plants with one or more of the following macronutrients: nitrogen (N), phosphorus (P), potassium (K), **calcium (Ca)** magnesium (Mg), ~~calcium (Ca), sulphur (S) or sodium (Na)~~ **or sulphur (S)**.

2. Contaminants must not be present in the ~~CE~~-marked EU fertilising product by more than the following quantities:

(a) Cadmium (Cd)

(~~i~~+) Where the ~~CE~~-marked EU fertilising product has a total phosphorus (P) content of less than 5 % phosphorus pentoxide (P₂O₅)-equivalent by mass: 3 mg/kg dry matter, or

(~~ii~~ 2) Where the ~~CE~~-marked EU fertilising product has a total phosphorus (P) content of 5 % phosphorus pentoxide (P₂O₅)-equivalent or more by mass ('phosphate fertiliser'):

- As of [Publications office, please insert the date **two eight years after the entry-into-force** of application of this Regulation]: 60 mg/kg phosphorus pentoxide (P₂O₅),
- ~~As of [Publications office, please insert the date **five years after the entry-into-force** occurring three years after the date of application of this Regulation]: 40 mg/kg phosphorus pentoxide (P₂O₅), and~~
- ~~As of [Publications office, please insert the date **fourteen years after the entry-into-force** occurring twelve years after the date of application of this Regulation]: 20 mg/kg phosphorus pentoxide (P₂O₅),~~

(b) Hexavalent chromium (Cr VI)	2 mg/kg dry matter,
(c) Mercury (Hg)	<u>1</u> 2 mg/kg dry matter,
(d) Nickel (Ni)	<u>100</u> 120 mg/kg dry matter,
(e) Lead (Pb)	<u>120</u> 150 mg/kg dry matter,
(f) Arsenic (As)	<u>40</u> 60 mg/kg dry matter,
(g) Biuret (C ₂ H ₅ N ₃ O ₂)	12 g/kg dry matter, and
(h) Perchlorate (ClO ₄ ⁻)	50 mg/kg dry matter.

2a. Copper (Cu) must not be present in the EU fertilising product by more than 600 mg/kg dry matter, and zinc (Zn) must not be present in the EU fertilising product by more than 1500 mg/kg dry matter. However, these limit values shall not apply where the copper or zinc has been intentionally added to the fertilising product for the purpose of correcting the soil micronutrient deficiency providing plants with micronutrients and is declared in accordance with Annex III.

PFC 1(C)(I)(a): Solid inorganic macronutrient fertiliser

A solid inorganic **macronutrient** fertiliser **shall be in solid form.** ~~shall be an inorganic macronutrient fertiliser, which is neither in suspension nor in solution within the meaning of PFC 1(C)(I)(b) in this Annex.~~

PFC 1(C)(I)(a)(i): Straight solid inorganic macronutrient fertiliser

1. A straight solid inorganic macronutrient fertiliser shall have a declared content of not more than one nutrient.
2. The ~~CE~~-marked EU fertilising product shall contain one of the following declared nutrients ~~in:~~
 - a) the minimum quantity of stated:
 - 10% by mass of total nitrogen (N), or
 - 12% by mass of total phosphorus pentoxide (P₂O₅), or
 - 6% by mass of total potassium oxide (K₂O), or
 - 5% by mass of total magnesium oxide (MgO), or
 - 12% by mass of total calcium oxide (CaO), or
 - 10% by mass of total sulphur trioxide (SO₃), ~~or-~~
 - 1% by mass of total sodium oxide (Na₂O), however the maximum quantity shall not exceed 40 % by mass.

PFC 1(C)(I)(a)(ii): Compound solid inorganic macronutrient fertiliser

1. A compound solid inorganic macronutrient fertiliser shall have a declared content of more than one nutrient.
2. The ~~CE~~-marked EU fertilising product shall contain more than one of the following declared nutrients in

a) the minimum quantities of ~~stated~~:

- 3% by mass of total nitrogen (N), or
- 3% by mass of total phosphorus pentoxide (P₂O₅), or
- 3% by mass of total potassium oxide (K₂O), or
- 1,5% by mass of total magnesium oxide (MgO), or
- 1,5% by mass of total calcium oxide (CaO), or
- 1,5% by mass of total sulphur trioxide (SO₃), or
- 1% by mass of total sodium oxide (Na₂O), **however the maximum quantity shall not exceed 40 % by mass.**

b) 18% by mass of total sum of all declared nutrients-referred to in point a) N, P₂O₅ and K₂O.

PFC 1(C)(I)(a)(i ii)(A): Straight or compound solid inorganic macronutrient ammonium nitrate fertiliser of high nitrogen content

1. A straight or compound solid inorganic macronutrient ammonium nitrate fertiliser of high nitrogen content shall be ammonium nitrate (NH₄NO₃)-based and contain 28 % or more by mass of nitrogen (N) as a result of ammonium nitrate (NH₄NO₃).
2. Any matter other than ammonium nitrate (NH₄NO₃) shall be inert towards ammonium nitrate (NH₄NO₃).
3. The ~~CE marked~~ **EU** fertilising product shall be made available to the end-user only in packaged form. The package shall be closed in such a way or by such a device that, when it is opened, the fastening, the fastening seal or the package itself is irreparably damaged. Valve sacks may be used.
4. The oil retention of the ~~CE marked~~ **EU** fertilising product, following two thermal cycles as described under Heading 4.1 in Module A1 in Annex IV, must not exceed 4 % by mass.
5. The detonation resistance of the ~~CE marked~~ **EU** fertilising product shall be such, that
 - following five thermal cycles as described under Heading 4.2 in Module A1 in Annex IV,
 - in two detonation resistance tests as described under Heading 4.3 in module A1 in Annex IV,one or more of the supporting lead cylinders is crushed by less than 5 %.

6. The percentage by mass of combustible material measured as carbon (C) must not exceed
 - 0,2 % for ~~CE~~-marked EU fertilising products having a nitrogen (N) content of at least 31,5 % by mass, and
 - 0,4 % for ~~CE~~-marked EU fertilising products having a nitrogen (N) content of at least 28 % but less than 31,5 % by mass.
7. A solution of 10 g of the ~~CE~~-marked EU fertilising product in 100 ml of water must have a pH of at least 4,5.
8. Not more than 5 % by mass of the ~~CE~~-marked EU fertilising product shall pass through a 1 mm mesh sieve, and not more than 3 % by mass shall pass through a 0,5 mm mesh sieve.
9. The copper (Cu) content shall not be higher than 10 mg/kg, and the chlorine (Cl) content shall not be higher than 200 mg/kg.

PFC 1(C)(I)(b): Liquid inorganic macronutrient fertiliser

A liquid inorganic macronutrient fertiliser shall be **in liquid form** ~~an inorganic macronutrient fertiliser in suspension or in solution, where~~

- ~~a suspension means a two phase dispersion in which solid particles are maintained in suspension in the liquid phase, and~~
- ~~a solution means a liquid that is free of solid particles.~~

PFC 1(C)(I)(b)(i): Straight liquid inorganic macronutrient fertiliser

1. A straight liquid inorganic macronutrient fertiliser shall have a declared content of not more than one nutrient.
2. The ~~CE~~-marked EU fertilising product shall contain one of the following declared nutrients in **a)** the minimum quantity **of stated**:
 - 5% by mass of total nitrogen (N), **or**
 - 5% by mass of total phosphorus pentoxide (P₂O₅), **or**
 - 3% by mass of total potassium oxide (K₂O), **or**
 - 2% by mass of total magnesium oxide (MgO), **or**
 - 6% by mass of total calcium oxide (CaO), **or**
 - 5% by mass of total sulphur trioxide (SO₃), or
 - 1% by mass of total sodium oxide (Na₂O), **however the maximum quantity shall not exceed 40 % by mass.**

PFC 1(C)(I)(b)(ii): Compound liquid inorganic macronutrient fertiliser

1. A compound liquid inorganic macronutrient fertiliser shall have a declared content of more than one nutrient.
2. The ~~CE~~-marked EU fertilising product shall contain more than one of the following declared nutrients in

a) the minimum quantities of stated:

- 1,5% by mass of total nitrogen (N), **or**
- 1,5% by mass of total phosphorus pentoxide (P₂O₅), **or**
- 1,5% by mass of total potassium oxide (K₂O), **or**
- 0,75% by mass of total magnesium oxide (MgO), **or**
- 0,75% by mass of total calcium oxide (CaO), **or**
- 0,75% by mass of total sulphur trioxide (SO₃), or
- 0, **125%** by mass of total sodium oxide (Na₂O), **however the maximum quantity shall not exceed 20 % by mass.**

b) 7% by mass of total sum of all declared nutrients-referred to in point a) N, P₂O₅ and K₂O.

PFC 1(C)(II): Inorganic micronutrient fertiliser

1. An inorganic micronutrient fertiliser shall be an inorganic fertiliser other than a macronutrient fertiliser aimed at providing one or more of the following nutrients: boron (B), cobalt (Co), copper (Cu), iron (Fe), manganese (Mn), molybdenum (Mo) or zinc (Zn).
2. Micronutrient fertilisers shall be made available to the end-user only in packaged form.
3. Contaminants must not be present in the ~~CE~~-marked EU fertilising product by more than the following quantities:

Contaminant	Maximum concentration of contaminants <u>expressed in mg by mass</u>, in relation to the total micronutrient content <u>expressed in kg</u>. (mg/kg of total <u>micronutrient content</u>, <u>which means</u> boron (B), cobalt (Co), copper (Cu), iron (Fe), manganese (Mn), molybdenum (Mo), and zinc (Zn))
Arsenic (As)	1000
Cadmium (Cd)	200
Lead (Pb)	600
Mercury (Hg)	100
Nickel (Ni)	2000

PFC 1(C)(II)(a): Straight inorganic micronutrient fertiliser

1. A straight inorganic micronutrient fertiliser shall have a declared content of not more than one nutrient.
2. The ~~CE~~-marked EU fertilising product shall comply with the one of the typologies, descriptions and corresponding minimum nutrient content requirements in the table below:

Typology	Description	Minimum nutrient content
Micronutrient salt fertiliser	A chemically obtained solid micronutrient fertiliser containing a mineral ion salt, oxide or hydroxide as its essential ingredient	10% by mass of the CE <u>EU</u> fertilising product shall consist of water-soluble micronutrient
<u>Micronutrient oxide or hydroxide fertiliser</u>	<u>A chemically obtained solid micronutrient fertiliser containing oxide or hydroxide as its essential ingredient</u>	<u>10% by mass of the EU fertilising product shall consist of water-soluble micronutrient</u>
Micronutrient-based fertiliser	A micronutrient fertiliser combining a micronutrient salt fertiliser with one or more other micronutrient salt fertilisers and/or with a single micronutrient chelate	5% by mass of the CE <u>EU</u> fertilising product shall consist of micronutrient
Micronutrient solution fertiliser	An aqueous solution of different forms of a micronutrient fertiliser	2% by mass of the CE <u>EU</u> fertilising product shall consist of water-soluble micronutrient

<p>Micronutrient suspension fertiliser</p>	<p>A product obtained by suspending different forms of a micronutrient fertiliser</p>	<p>2% by mass of the CE <u>EU</u> fertilising product shall consist of micronutrient</p>
<p>Micronutrient chelate fertiliser</p>	<p>A water-soluble product in which the declared micronutrient is chemically combined with chelating agent(s) fulfilling the requirements of PFC 5(B) <u>CMC 1</u></p>	<ul style="list-style-type: none"> • 5% by mass of the CE <u>EU</u> fertilising product shall consist of water-soluble micronutrient, and • at least 80% of the water-soluble micronutrient shall be chelated by a chelating agent fulfilling the requirements of PFC 5(B) <u>CMC 1</u>

<p><u>UVCB²³ iron chelates</u></p>	<p><u>A water-soluble product in which the declared iron is chemically combined with chelating agent(s) fulfilling the requirements of CMC 1</u></p>	<ul style="list-style-type: none"> • <u>5% by mass of the CE marked EU fertilising product shall consist of water-soluble micronutrient, and</u> • <u>at least 80% of the water-soluble iron shall be chelated and at least 50% of the water soluble iron shall be chelated by a chelating agent fulfilling the requirements of CMC 1</u>
--	---	---

²³ Regarding REACH: substance of unknown or variable composition, complex reaction products or biological materials.

<p>Micronutrient complex fertiliser</p>	<p>A water-soluble product in which the declared micronutrient is chemically combined with complexing agent(s) fulfilling the requirements of PFC 5(C) <u>CMC 1</u></p>	<ul style="list-style-type: none"> • 5% by mass of the CE <u>EU</u> fertilising product shall consist of water-soluble micronutrient, and • at least 80% of the water-soluble micronutrient shall be complexed by a complexing agent fulfilling the requirements of PFC 5(C) <u>CMC 1</u>
---	---	---

PFC 1(C)(II)(b): Compound inorganic micronutrient fertiliser

1. A compound inorganic micronutrient fertiliser shall have a declared content of more than one micronutrient.
2. The ~~CE~~-marked EU fertilising product shall contain **the sum of** declared nutrients in ~~at least one of~~ the following **minimum** quantities:
 - 2% by mass for fertilisers **in liquid form** ~~suspension or solution ('liquid compound inorganic micronutrient fertilisers')~~, where
 - ~~a suspension means a two-phase dispersion in which solid particles are maintained in suspension in the liquid phase, and~~
 - ~~a solution means a liquid that is free of solid particles, and~~ **or**
 - 5% by mass for ~~other~~ fertilisers **in solid form** (~~'solid compound inorganic micronutrient fertilisers'~~).

PFC 2: LIMING MATERIAL

1. A liming material shall be a ~~CE-marked~~ **EU** fertilising product ~~aimed at the function of~~ **which is to** correcting soil acidity, ~~and containing~~ **It shall contain** oxides, hydroxides, carbonates or silicates of the nutrients calcium (Ca) or magnesium (Mg).
2. Contaminants must not be present in the ~~CE-marked~~ EU fertilising product by more than the following quantities:
 - Cadmium (Cd) 2 ~~3~~ mg/kg dry matter,
 - Hexavalent chromium (Cr VI) 2 mg/kg dry matter,
 - Mercury (Hg) 1 ~~2~~ mg/kg dry matter,
 - Nickel (Ni) 90 mg/kg dry matter,
 - Lead (Pb) 120 ~~200~~ mg/kg dry matter,
 - Arsenic (As) 40 ~~120~~ mg/kg dry matter

2a. Copper (Cu) must not be present in the EU fertilising product by more than 300 mg/kg dry matter, and zinc (Zn) must not be present in the EU fertilising product by more than 800 mg/kg dry matter.

3. The following parameters determined on the mass of the fertilising product dry matter shall be met:

- Minimum neutralising value: 15 (equivalent CaO) or 9 (equivalent HO-), and
- Minimum reactivity: 10% (**hydrochloric acid test**) or 50% after 6 months (incubation test).

PFC 3: SOIL IMPROVER

A soil improver shall be a ~~CE-marked~~ EU fertilising product aimed at being added to the soil for the purpose of the function of which is to maintaining, improving or protecting the physical or chemical properties, the structure or the biological activity of the soil to which it is added.

PFC 3(A): Organic soil improver

1. An organic soil improver shall consist of material, 95 % of which is ~~of exclusively of material~~ of solely biological origin, including leonardite and lignite, but excluding other materials which are ~~is~~ fossilized or embedded in geological formations.
2. Contaminants must not be present in the ~~CE-marked~~ EU fertilising product by more than the following quantities:

- Cadmium (Cd) 2.3 mg/kg dry matter,
- Hexavalent chromium (Cr VI) 2 mg/kg dry matter,
- Mercury (Hg) 1 mg/kg dry matter,
- Nickel (Ni) 50 mg/kg dry matter, ~~and~~
- Lead (Pb`) 120 mg/kg dry matter.
- Arsenic (As) 40 mg/kg dry matter

2a. Copper (Cu) must not be present in the EU fertilising product by more than 300 mg/kg dry matter, and zinc (Zn) must not be present in the EU fertilising product by more than 800 mg/kg dry matter.

3. Pathogens must not be present in the organic soil improver in a concentration of more than the respective limits outlined in the table below

<u>Micro-organisms to be tested</u>	<u>Sampling plans</u>			<u>Limit</u>
	<u>n</u>	<u>c</u>	<u>m</u>	<u>M</u>
<u>Salmonella spp</u>	<u>5</u>	<u>0</u>	<u>0</u>	<u>Absence in 25 g or 25 ml</u>
<u>Escherichia coli</u> <u>or</u> <u>Enterococcaceae</u>	<u>5</u>	<u>5</u>	<u>0</u>	<u>1000 in 1g or 1 ml</u>

where n = number of samples to be tested,

c = number of samples where the number of bacteria expressed in CFU may be between m and M,

m= threshold value for the number of bacteria expressed in CFU that is considered satisfactory,

M= maximum value of the number of bacteria expressed in CFU.

When the CE marked EU fertilising product contains an animal by product as defined in Regulation (EC) No 1069/2009

- (a) ~~Absence of~~ *Salmonella* spp. shall be **demonstrated in accordance with the method described in Annex IV, part G, chapter 3 of Regulation (EU) No. 142/2011** absent in a 25 g sample of the CE marked EU fertilising product.
- (b) None of the two following types of bacteria shall be present in the CE marked EU fertilising product in a concentration of more than 1000 CFU/g fresh mass:
- ~~Escherichia coli, or~~
 - ~~Enterococcaceae.~~

This shall be demonstrated by measuring the presence of at least one of those two types of bacteria.

In the organic soil improver:

~~(a) Absence of~~ *Salmonella* spp. and **maximum** presence of *Escherichia coli* and *Enterococcaceae* shall be **demonstrated in accordance with the standards laid down in Annex XI, chapter I, section 2 (d) of Regulation (EU) No. 142/2011** absent in a 25 g sample of the CE marked EU fertilising product.

Absence of resistant **Parasites** such as eggs of ***Ascaris* spp. and *Toxocara* spp. must not be present in 100 g or 100 ml of the organic soil improver shall be demonstrated according to a scientifically accepted method.**

4. The CE marked EU fertilising product shall contain **20** 40% or more dry matter.
5. Organic carbon (C_{org}) shall be present in the CE marked EU fertilising product by at least 7.5 % by mass.

PFC 3(B): Inorganic soil improver

1. An inorganic soil improver shall be a soil improver other than an organic soil improver.
2. Contaminants must not be present in the ~~CE~~-marked **EU** fertilising product by more than the following quantities:

- Cadmium (Cd) 1,5 mg/kg dry matter,
- Hexavalent chromium (Cr VI) 2 mg/kg dry matter,
- Mercury (Hg) 1 mg/kg dry matter,
- Nickel (Ni) 100 mg/kg dry matter, ~~and~~
- Lead (Pb) 120 ~~150~~ mg/kg dry matter
- Arsenic (As) 40 mg/kg dry matter

2a. Copper (Cu) must not be present in the EU fertilising product by more than 300 mg/kg dry matter, and zinc (Zn) must not be present in the EU fertilising product by more than 800 mg/kg dry matter.

PFC 4: GROWING MEDIUM

1. A growing medium shall be **an EU fertilising product the function of which is for plants or mushrooms to grow in** ~~a material other than soil intended for use as a substrate for root development.~~

For the purpose of paragraph 1, plants are understood to include algae.

2. Contaminants must not be present in the ~~CE marked~~ **EU** fertilising product by more than the following quantities:

- Cadmium (Cd) 3 ~~1,5~~ mg/kg dry matter,
- Hexavalent chromium (Cr VI) 2 mg/kg dry matter,
- Mercury (Hg) 1 mg/kg dry matter,
- Nickel (Ni) 100 ~~50~~ mg/kg dry matter, and
- Lead (Pb) 150 ~~120~~ mg/kg dry matter.
- **Arsenic (As)** **40 mg/kg dry matter**

- 2a. Copper (Cu) must not be present in the EU fertilising product by more than 200 mg/kg dry matter, and zinc (Zn) must not be present in the EU fertilising product by more than 500 mg/kg dry matter.**

3. Pathogens must not be present in the growing medium in a concentration of more than the respective limits outlined in the table below

<u>Micro-organisms to be tested</u>	<u>Sampling plans</u>			<u>Limit</u>
	<u>n</u>	<u>c</u>	<u>m</u>	<u>M</u>
<u>Salmonella spp</u>	<u>5</u>	<u>0</u>	<u>0</u>	<u>Absence in 25 g or 25 ml</u>
<u>Escherichia coli</u> <u>or</u> <u>Enterococcaceae</u>	<u>5</u>	<u>5</u>	<u>0</u>	<u>1000 in 1g or 1 ml</u>

where n = number of samples to be tested,

c = number of samples where the number of bacteria expressed in CFU may be between m and M,

m= threshold value for the number of bacteria expressed in CFU that is considered satisfactory,

M= maximum value of the number of bacteria expressed in CFU.

In the growing medium:

~~(a) — Absence of Salmonella spp. and **maximum** presence of Escherichia coli and Enterococcaceae shall be **demonstrated in accordance with the standards laid down in Annex XI, chapter I, section 2 (d) of Regulation (EU) No. 142/2011**, absent in a 25 g sample of the CE marked **EU** fertilising product.~~

~~Absence of resistant **Parasites** such as eggs of **Ascaris spp. and Toxocara spp. must not be present in 100 g or 100 ml of the growing medium shall be demonstrated according to a scientifically accepted method.**~~

~~3. — Salmonella spp. shall be absent in a 25 g sample of the CE marked **EU** fertilising product.~~

~~4. — None of the two following types of bacteria shall be present in the CE marked **EU** fertilising product in a concentration of more than 1000 CFU/g fresh mass:~~

~~(a) — Escherichia coli, or~~

~~(b) — Enterococcaceae.~~

~~This shall be demonstrated by measuring the presence of at least one of those two types of bacteria.~~

PFC 5: AGRONOMIC ADDITIVE

An agronomic additive shall be a CE marked EU fertilising product intended to be added to a product providing plants with nutrient, with the intention to improve that product's nutrient release patterns.

PFC 5(A): INHIBITOR

1. An inhibitor shall be a an EU fertilising product the function of which is to improve the nutrient release patterns of a product providing plants with nutrients by delayings or stopings the activity of specific groups of micro-organisms or enzymes.
2. ~~Each substance shall have been registered pursuant to Regulation (EC) No 1907/2006²⁴, in a dossier containing~~
 - (a) ~~the information provided for by Annex VI, VII and VIII of Regulation (EC) No 1907/2006, and~~
 - (b) ~~a chemical safety report pursuant to Article 14 of Regulation (EC) No 1907/2006 covering the use as fertilising product,~~

~~unless explicitly covered by one of the registration obligation exemptions provided for by Annex IV to that Regulation or by points 6, 7, 8, or 9 of Annex V to that Regulation.~~

²⁴ In the case of an additive recovered in the European Union, this condition is fulfilled if the additive is the same, within the meaning of Article 2(7)(d)(i) of Regulation (EC) No 1907/2006, as a substance registered in a dossier containing the information here indicated, and if information is available to the fertilising product manufacturer within the meaning of Article 2(7)(d)(ii) of Regulation (EC) No 1907/2006.

PFC 5(A)(F): Nitrification inhibitor

1. A nitrification inhibitor shall inhibit the biological oxidation of ammoniacal nitrogen ($\text{NH}_3\text{-N}$) to nitrite nitrogen (NO_2^-), thus slowing the formation of nitrate nitrogen (NO_3^-).
2. **The** ~~A soil incubation test measuring the~~ ammoniacal nitrogen ($\text{NH}_3\text{-N}$) oxidation rate **shall be measured either** by
 - ammoniacal nitrogen ($\text{NH}_3\text{-N}$) disappearance, or
 - the sum of nitrite nitrogen (NO_2^-) and nitrate nitrogen (NO_3^-) production with respect to time

Compared to a control sample where the nitrification inhibitor has not been added, ~~in~~ a soil sample **containing** where the nitrification inhibitor ~~has been added~~ shall show a **20% reduction in** ~~statistical difference in~~ ammoniacal nitrogen ($\text{NH}_3\text{-N}$) oxidation rate **based on an analysis 14 days after application at the 95% confidence level** ~~when compared to a control sample where the nitrification inhibitor has not been added.~~

PFC 5(AB)(H): Urease inhibitor

1. An urease inhibitor shall inhibit hydrolytic action on urea ($\text{CH}_4\text{N}_2\text{O}$) by the urease enzyme, primarily targeted to reduce ammonia volatilisation.
2. **Compared to a control sample where the urease inhibitor has not been added, an in-vitro test containing the urease inhibitor shall show a 20% reduction in measuring of the rate of hydrolysis of urea ($\text{CH}_4\text{N}_2\text{O}$) based on an analysis 14 days after application at the 95% confidence level** with respect to time in a soil sample where the urease inhibitor has been added shall show a statistical difference in hydrolysis rate when compared to a control sample where the urease inhibitor has not been added.

PFC 5(AC)(H): Denitrification inhibitor

1. **A denitrification inhibitor shall inhibit the formation of nitrous oxide (N_2O) by slowing down or blocking the conversion of nitrate (NO_3^-) to dinitrogen (N_2) without influencing the nitrification process as described in PFC 5 (A).**
2. **Compared to a control sample where the denitrification inhibitor has not been added, an in vitro test containing the denitrification inhibitor shall show a 20 % reduction in rate of the release of nitrous oxide based on an analysis 14 days after application at the 95 % confidence level.**

PFC 5(B): Chelating agent (moved to CMC 1)

1. ~~A chelating agent shall be an organic substance intended to enhance nutrients' long term availability to plants consisting in a molecule which
 - ~~has two or more sites that donate electron pairs to a central transition metal cation (zinc (Zn), copper (Cu), iron (Fe), manganese (Mn), magnesium (Mg), calcium (Ca) or cobalt (Co)), and which~~
 - ~~is large enough to form a five or six membered ring structure.~~~~
2. ~~The substance shall have been registered pursuant to Regulation (EC) No 1907/2006²⁵, in a dossier containing
 - (a) ~~the information provided for by Annex VI, VII and VIII of Regulation (EC) No 1907/2006, and~~
 - (b) ~~a chemical safety report pursuant to Article 14 of Regulation (EC) No 1907/2006 covering the use as fertilising product,~~unless explicitly covered by one of the registration obligation exemptions provided for by Annex IV to that Regulation or by points 6, 7, 8, or 9 of Annex V to that Regulation.~~
3. ~~After 3 days in standard Hoagland solution at pH 7 and 8, the CE marked EU fertilising product shall remain stable.~~

²⁵ In the case of an additive recovered in the European Union, this condition is fulfilled if the additive is the same, within the meaning of Article 2(7)(d)(i) of Regulation (EC) No 1907/2006, as a substance registered in a dossier containing the information here indicated, and if information is available to the fertilising product manufacturer within the meaning of Article 2(7)(d)(ii) of Regulation (EC) No 1907/2006.

PFC 5(C): Complexing agent (moved to CMC 1)

1. ~~A complexing agent shall be an organic substance intended to enhance nutrients' long term availability to plants, which can form a flat or steric structure with one di or three valent transition metal cation.~~
2. ~~The substance shall have been registered pursuant to Regulation (EC) No 1907/2006²⁶, in a dossier containing~~
 - (a) ~~the information provided for by Annex VI, VII and VIII of Regulation (EC) No 1907/2006, and~~
 - (b) ~~a chemical safety report pursuant to Article 14 of Regulation (EC) No 1907/2006 covering the use as fertilising product,~~

~~unless explicitly covered by one of the registration obligation exemptions provided for by Annex IV to that Regulation or by points 6, 7, 8, or 9 of Annex V to that Regulation.~~
3. ~~After 1 day in water solution at pH 6 and 7, the CE marked EU fertilising product shall remain stable.~~

²⁶ In the case of an additive recovered in the European Union, this condition is fulfilled if the additive is the same, within the meaning of Article 2(7)(d)(i) of Regulation (EC) No 1907/2006, as a substance registered in a dossier containing the information here indicated, and if information is available to the fertilising product manufacturer within the meaning of Article 2(7)(d)(ii) of Regulation (EC) No 1907/2006.

PFC 6: PLANT BIOSTIMULANT

1. A plant biostimulant shall be a ~~CE~~-marked EU fertilising product **the function of which is to stimulate** ~~stimulating~~ plant nutrition processes independently of the product's nutrient content with the sole aim of improving one or more of the following characteristics of the plant:
 - (a) nutrient use efficiency,
 - (b) tolerance to abiotic stress, or
 - (c) ~~crop~~ quality traits.

2. Contaminants must not be present in the ~~CE~~-marked EU fertilising product by more than the following quantities:
 - Cadmium (Cd) 3 1,5 mg/kg dry matter,
 - Hexavalent chromium (Cr VI) 2 mg/kg dry matter, ~~and~~
 - Lead (Pb) 120 mg/kg dry matter.
 - Mercury (Hg) 1 mg/kg dry matter,
 - Nickel (Ni) 50 mg/kg dry matter.
 - Arsenic (As) 40 mg/kg dry matter.

2a. Copper (Cu) must not be present in the EU fertilising product by more than 600 mg/kg dry matter, and zinc (Zn) must not be present in the EU fertilising product by more than 1500 mg/kg dry matter.

3. The plant biostimulant shall have the effects that are claimed on the label for the ~~cro~~ps **plants** specified thereon.

PFC 6(A): Microbial plant biostimulant

1. A microbial plant biostimulant shall consist ~~solely~~ of a micro-organism or a consortium of micro-organisms referred to in Component Material Category 7 of Annex II.
2. ~~Contaminants must not be present in the CE marked EU fertilising product by more than the following quantities:~~

- ~~• Mercury (Hg) — 1 mg/kg dry matter, and~~

- ~~• Nickel (Ni) — 50 mg/kg dry matter.~~

~~*Salmonella spp.* shall be absent in a 25 g or 25 ml sample of the CE marked EU fertilising product.~~

~~*Escherichia coli* shall be absent in a 1 g or 1 ml sample of the CE marked EU fertilising product.~~

~~Enterococcaceae must not be present in the CE marked EU fertilising product by more than 10 CFU/g fresh mass.~~

~~*Listeria monocytogenes* shall be absent in a 25 g or 25 ml sample of the CE marked EU fertilising product.~~

~~*Vibrio spp.* shall be absent in a 25 g or 25 ml sample of the CE marked EU fertilising product.~~

~~*Shigella spp.* shall be absent in a 25 g or 25 ml sample of the CE marked EU fertilising product.~~

~~Staphylococcus aureus shall be absent in a 1 g or 1 ml sample of the CE marked EU fertilising product.~~

~~Aerobic plate count shall not exceed 10^5 CFU/g or ml sample of the CE marked EU fertilising product, unless the microbial biostimulant is an aerobic bacterium.~~

~~Yeast and mould count shall not exceed 1000 CFU/g or ml sample of the CE marked EU fertilising product, unless the microbial biostimulant is a fungus.~~

Pathogens must not be present in the microbial plant biostimulant in a concentration of more than the respective limits outlined in the table below:

<u>Micro-organisms/their toxins, metabolites</u>	<u>Sampling plans²⁷</u>		<u>Limit</u>
	<u>n</u>	<u>c</u>	
<u>Salmonella spp</u>	<u>5</u>	<u>0</u>	<u>Absence in 25g or 25 ml</u>
<u>Escherichia coli</u>	<u>5</u>	<u>0</u>	<u>Absence in 1g or 1ml</u>
<u>Listeria monocytogenes</u>	<u>5</u>	<u>0</u>	<u>Absence in 25g or 25 ml</u>
<u>Vibrio spp</u>	<u>5</u>	<u>0</u>	<u>Absence in 25g or 25 ml</u>
<u>Shigella spp</u>	<u>5</u>	<u>0</u>	<u>Absence in 25g or 25 ml</u>
<u>Staphylococcus aureus</u>	<u>5</u>	<u>0</u>	<u>Absence in 25g or 25 ml</u>
<u>Enterococcaceae</u>	<u>5</u>	<u>2</u>	<u>10 CFU/g</u>
<u>Anaerobic plate count unless the microbial biostimulant is an aerobic bacterium</u>	<u>5</u>	<u>2</u>	<u>10⁵ CFU/g or ml</u>
<u>Yeast and mould count unless the microbial biostimulant is a fungus</u>	<u>5</u>	<u>2</u>	<u>1000 CFU/g or ml</u>

²⁷ **n= number of units comprising the sample; c= number of sample units giving values over the defined limit.**

12. When the microbial plant biostimulant **is in liquid form** consists of a suspension or a solution, where

- ~~a suspension means a two-phase dispersion in which solid particles are maintained in suspension in the liquid phase, and~~
- ~~a solution means a liquid that is free of solid particles,~~

the plant biostimulant shall have a pH **optimal for contained microorganisms and for plants** superior or equal to 4.

~~13. The shelf life of the microbial plant biostimulant shall be at least 6 months under the storage conditions specified on the label.~~

PFC 6(B): Non-microbial plant biostimulant

1. A non-microbial plant biostimulant shall be a plant biostimulant other than a microbial plant biostimulant.

PFC 6(B)(1): Organic non-microbial plant biostimulant

~~1.~~—An organic non-microbial plant biostimulant shall consist of a substance or a mixture containing **organic** carbon (C_{org}) of solely animal or plant origin.

~~2.~~—Contaminants must not be present in the CE marked **EU** fertilising product by more than the following quantities:

- ~~•~~ Mercury (Hg) ————— 1 mg/kg dry matter, and
- ~~•~~ Nickel (Ni) ————— 50 mg/kg dry matter.

2. Pathogens must not be present in the non-microbial plant stimulant in a concentration of more than the respective limits outlined in the table below

<u>Micro-organisms to be tested</u>	<u>Sampling plans</u>			<u>Limit</u>
	<u>n</u>	<u>c</u>	<u>m</u>	<u>M</u>
<u>Salmonella spp</u>	<u>5</u>	<u>0</u>	<u>0</u>	<u>Absence in 25 g or 25 ml</u>
<u>Escherichia coli</u> <u>or</u> <u>Enterococcaceae</u>	<u>5</u>	<u>5</u>	<u>0</u>	<u>1000 in 1g or 1 ml</u>

where n = number of samples to be tested,

c = number of samples where the number of bacteria expressed in CFU may be between m and M,

m= threshold value for the number of bacteria expressed in CFU that is considered satisfactory,

M= maximum value of the number of bacteria expressed in CFU.

In the non-microbial plant biostimulant:

~~(a) — Absence of Salmonella spp. and **maximum** presence of Escherichia coli and Enterococcaceae shall be **demonstrated in accordance with the standards laid down in Annex XI, chapter I, section 2 (d) of Regulation (EU) No. 142/2011**, absent in a 25-g sample of the CE-marked **EU** fertilising product.~~

~~— Absence of resistant **P**parasites such as eggs of *Ascaris* spp. **and Toxocara spp. must not be present in the non-microbial plant biostimulant shall be demonstrated according to a scientifically accepted method.**~~

4. — None of the two following types of bacteria shall be present in the CE-marked **EU** fertilising product by more than 1000 CFU/g fresh mass:

(a) — *Escherichia coli*, or

(b) — Enterococcaceae.

This shall be demonstrated by measuring the presence of at least one of those two types of bacteria.

PFC 6(B)(II): Inorganic non-microbial plant biostimulant

1. ~~An inorganic non-microbial plant biostimulant shall be a non-microbial plant biostimulant other than an organic non-microbial plant biostimulant.~~
2. ~~Contaminants must not be present in the CE marked EU fertilising product by more than the following quantities:~~
 - ~~Mercury (Hg) ————— 2 mg/kg dry matter,~~
 - ~~Nickel (Ni) ————— 120 mg/kg dry matter, and~~
 - ~~Arsenic (As) ————— 60 mg/kg dry matter.~~

PFC 7: FERTILISING PRODUCT BLEND

1. A fertilising product blend shall be a ~~CE-marked~~ EU fertilising product composed of two or more ~~CE-marked~~ EU fertilising products of category 1-6 **for which the compliance with the requirements of this Regulation of each component fertilising product in the blend has been demonstrated.**
2. ~~The compliance with the requirements of this Regulation of each component fertilising product in the blend shall have been demonstrated~~ in accordance with the conformity assessment procedure applicable to that component fertilising product.
3. The blending shall not change the nature of each component fertilising product **and shall not have**
 - ~~in a manner having~~ an adverse effect on human, animal or plant health, on safety, or on the environment, under reasonably foreseeable conditions of storage or use of the ~~CE marked~~ EU fertilising product blend, ~~or~~
 - ~~in any other significant manner.~~
4. The manufacturer of the blend shall assess the conformity of the blend with the requirements set out in paragraphs 1-3 above, ensure the blend's compliance with the labelling requirements laid down in Annex III, and assume responsibility pursuant to Article 15(4) of this Regulation for the compliance of the blend with the requirements of this Regulation by
 - drawing up an EU declaration of conformity for the ~~CE-marked~~ EU fertilising product blend in accordance with Article 6(2) of this Regulation, and
 - being in possession of the EU declaration of conformity of each of the component fertilising products.

5. Economic operators making ~~CE~~-marked EU fertilising product blends available on the market shall respect the following provisions of this Regulation with regard to the EU declaration of conformity of each component fertilising product as well as of the blend:
- Article 6(3) (manufacturers' obligation to keep the EU declaration of conformity);
 - Article 7(2)(a) (authorised representatives' obligation to keep the EU declaration of conformity);
 - ~~Article 8(2) (importers' obligation to ensure that the CE marked EU fertilising product is accompanied by the EU declaration of conformity);~~
 - Article 8(8) (importers' obligation to keep a copy of the EU declaration of conformity at the disposal of the market surveillance authorities); and
 - ~~Article 9(2) (distributors' obligation to verify that the CE marked EU fertilising product is accompanied by the EU declaration of conformity).~~

Component Material Categories

A ~~CE-marked~~**EU** fertilising product shall consist solely of component materials complying with the requirements for one or more of the Component Material Categories ('CMC') listed **in this Annex**.

The component materials, or the input materials used to produce them, shall not contain one of the substances for which maximum limit values are indicated in Annex I of this Regulation in such quantities as to jeopardise the ~~CE-marked~~**EU** fertilising product's compliance with one of the applicable requirements of that Annex.

PART I

OVERVIEW OF COMPONENT MATERIAL CATEGORIES

CMC 1: Virgin material substances and mixtures

CMC 2: ~~Non-processed or mechanically processed~~ Plants, plant parts or plant extracts

CMC 3: Compost

CMC 4: ~~Energy~~ Fresh crop digestate

CMC 5: Other digestate than fresh energy crop digestate

CMC 6: Food industry by-products

CMC 7: Micro-organisms

~~CMC 8: Agronomic additive~~ Inhibitors

CMC 9: Nutrient polymers

CMC 10: Other polymers than nutrient polymers

CMC 11: Certain products derived from animal by-products

PART II

REQUIREMENTS RELATED TO COMPONENT MATERIAL CATEGORIES

This Part defines the component materials of which ~~CE-marked~~ EU fertilising products shall solely consist.

CMC 1: VIRGIN MATERIAL SUBSTANCES AND MIXTURES

1. A ~~CE-marked~~ EU fertilising product may contain substances and mixtures, other than²⁸
 - (a) waste within the meaning of Directive 2008/98/EC,
 - (b) by-products within the meaning of Directive 2008/98/EC,
 - (c) materials formerly having constituted one of the materials mentioned in one of points a-b,
 - (d) animal by-products **or derived products** within the meaning of Regulation (EC) No 1069/2009, **or**
 - (e) polymers; ~~or~~
 - (f) ~~substances or mixtures intended to improve the nutrient release patterns of the CE marked~~ EU fertilising product into which they are incorporated.

²⁸ The exclusion of a material from CMC 1 does not prevent it from being an eligible component material by virtue of another CMC stipulating different requirements. See, for instance, CMC 11 on animal by-products, CMCs 9 and 10 on polymers, and CMC 8 on ~~agronomic additives~~ **inhibitors**.

2. All the substances incorporated into the ~~CE~~-marked EU fertilising product, in their own or in a mixture, shall have been registered pursuant to Regulation (EC) No 1907/2006, in a dossier containing

(a) the information provided for by Annex VI, VII and VIII of Regulation (EC) No 1907/2006, and

(b) a chemical safety report pursuant to Article 14 of Regulation (EC) No 1907/2006 covering the use as fertilising product,

unless explicitly covered by one of the registration obligation exemptions provided for by Annex IV to that Regulation or by points 6, 7, 8, or 9 of Annex V to that Regulation.

2a. Where the substance or one of the substances in the mixture is intended to enhance the long term availability to plants of micronutrients in the EU fertilising product, that substance shall be either a chelating agent or a complexing agent, and the following rules shall apply:

a) The chelating agent shall be an organic substance consisting in a molecule which

- **has two or more sites that donate electron pairs to a central transition-metal cation (zinc (Zn), copper (Cu), iron (Fe), manganese (Mn), magnesium (Mg), calcium (Ca) or cobalt (Co)), and which**
- **is large enough to form a five- or six- membered ring cyclic structure.**

The EU fertilising product shall remain stable in standard Hoagland solution at pH 7 and 8 for at least 3 days.

b) The complexing agent shall be an organic substance forming a flat or steric structure with one di or three valent transition metal cation (zinc (Zn), copper (Cu), iron (Fe), manganese (Mn) or cobalt (Co)).

The EU fertilising product shall remain stable in water solution at pH 6 and 7 for at least 1 day.

3a. Where the substance or one of the substances in the mixture is intended to improve the fertilising product's nutrient release patterns by delaying or stopping the activity of specific groups of micro-organisms or enzymes, that substance shall be an a nitrification inhibitor, a urease inhibitor, or a denitrification inhibitor, and the following rules shall apply:

a) The nitrification inhibitor shall inhibit the biological oxidation of ammoniacal nitrogen (NH₃-N) to nitrite nitrogen (NO₂-), thus slowing the formation of nitrate nitrogen (NO₃-).

The ammoniacal nitrogen (NH₃-N) oxidation rate shall be measured either by

- ammoniacal nitrogen (NH₃-N) disappearance, or**
- the sum of nitrite nitrogen (NO₂-) and nitrate nitrogen (NO₃-) production with respect to time**

Compared to a control sample where the nitrification inhibitor has not been added, a soil sample containing the nitrification inhibitor shall show a 20% reduction in ammoniacal nitrogen (NH₃-N) oxidation rate based on an analysis 14 days after application at the 95% confidence level.

At least 50% of the total nitrogen (N) content of the fertilising product shall consist of the nitrogen (N) forms ammonium (NH₄⁺) and urea (CH₄N₂O).

b) The urease inhibitor shall inhibit hydrolytic action on urea (CH₄N₂O) by the urease enzyme, primarily targeted to reduce ammonia volatilisation. Compared to a control sample where the urease inhibitor has not been added, an in-vitro test containing the urease inhibitor shall show a 20% reduction in the rate of hydrolysis of urea (CH₄N₂O) based on an analysis 14 days after application at the 95% confidence level.

At least 50% of the total nitrogen (N) content of the fertilising product shall consist of the nitrogen (N) form urea (CH₄N₂O).

c) The denitrification inhibitor shall inhibit the formation of nitrous oxide (N₂O) by slowing down or blocking the conversion of nitrate (NO₃⁻) to dinitrogen (N₂) without influencing the nitrification process as described in PFC 5 (A).

Compared to a control sample where the denitrification inhibitor has not been added, an in vitro test containing the denitrification inhibitor shall show a 20 % reduction in rate of the release of nitrous oxide based on an analysis 14 days after application at the 95 % confidence level.

CMC 2: ~~NON-PROCESSED OR MECHANICALLY PROCESSED~~ PLANTS, PLANT PARTS OR PLANT EXTRACTS

1. A ~~CE-marked~~ **EU** fertilising product may contain plants, plant parts or plant extracts having undergone no other processing than ~~mechanical processing such as~~ cutting, grinding, **sieving, sifting**, centrifugation, pressing, drying, freeze-drying, ~~buffering~~ or extraction with water **or supercritical CO₂ extraction**. ~~Extraction with alkali or acid may be used if it is followed by an appropriate neutralisation technique.~~
2. For the purpose of paragraph 1, plants are understood to include **mushrooms**, algae and exclude blue-green algae (**cyanobacteria**).

CMC 3: COMPOST

1. A ~~CE marked~~ EU fertilising product may contain compost obtained through aerobic composting of exclusively one or more of the following input materials:
- (a) Bio-waste within the meaning of Directive 2008/98/EC resulting from separate bio-waste collection at source;
 - (b) **Products derived from animal by-products referred to in Article 32 of categories 2 and 3 according to Regulation (EC) No 1069/2009 for which the end point in the manufacturing chain has been determined in accordance with the third paragraph of Article 5(2) of that Regulation;**
 - (c) Living or dead organisms or parts thereof, which are unprocessed or processed only by manual, mechanical or gravitational means, by dissolution in water, by flotation, by extraction with water, by steam distillation or by heating solely to remove water, or which are extracted from air by any means, except
 - the organic fraction of mixed municipal household waste separated through mechanical, physicochemical, biological and/or manual treatment,
 - sewage sludge, industrial sludge or dredging sludge, and
 - animal by-products **or derived products falling within the scope** of category 1 according to Regulation (EC) No 1069/2009 **for which no end point in the manufacturing chain has been determined in accordance with the third paragraph of Article 5(2) of that Regulation;**
- of category 1 according to Regulation (EC) No 1069/2009;

(d) Composting additives which are necessary to improve the process performance or the environmental performance of the composting process provided that

- the additive is registered pursuant to Regulation (EC) No 1907/2006²⁹, in a dossier containing
 - the information provided for by Annex VI, VII and VIII of Regulation (EC) No 1907/2006, and
 - a chemical safety report pursuant to Article 14 of Regulation (EC) No 1907/2006 covering the use as fertilising product,

unless explicitly covered by one of the registration obligation exemptions provided for by Annex IV to that Regulation or by points 6, 7, 8, or 9 of Annex V to that Regulation, and

- the total concentration of all additives does not exceed 5 % of the total input material weight; or

(e) Any material listed in points (a)- ~~to~~ (d) which

- has previously been composted or digested, and
- contains no more than 6 mg/kg dry matter of PAH₁₆³⁰.

²⁹ In the case of an additive recovered in the European Union, this condition is fulfilled if the additive is the same, within the meaning of Article 2(7)(d)(i) of Regulation (EC) No 1907/2006, as a substance registered in a dossier containing the information here indicated, and if information is available to the fertilising product manufacturer within the meaning of Article 2(7)(d)(ii) of Regulation (EC) No 1907/2006.

³⁰ Sum of naphthalene, acenaphthylene, acenaphthene, fluorene, phenanthrene, anthracene, fluoranthene, pyrene, benzo[a]anthracene, chrysene, benzo[b]fluoranthene, benzo[k]fluoranthene, benzo[a]pyrene, indeno[1,2,3-cd]pyrene, dibenzo[a,h]anthracene and benzo[ghi]perylene

2. The composting shall take place in a plant
 - **in a separated production line** which only processes input materials referred to in paragraph 1 above, and
 - where physical contacts between input and output materials ~~in separated lines~~ shall be avoided, including during storage.

3. The aerobic composting shall consist in controlled decomposition of biodegradable materials, which is predominantly aerobic and which allows the development of temperatures suitable for thermophilic bacteria as a result of biologically produced heat. All parts of each batch shall be **either** regularly and thoroughly moved **and turned or subject to forced ventilation** in order to ensure the correct sanitation and homogeneity of the material. During the composting process, all parts of each batch shall have one of the following temperature-time profiles:
 - **70°C or more for at least 3 days,**
 - 65°C or more for at least 5 days,
 - 60°C or more for at least 7 days, or
 - 55°C or more for at least 14 days.

4. The compost shall contain

(a) no more than 6 mg/kg dry matter of PAH₁₆³¹, and

(aa) no more than 3 g/kg dry matter of macroscopic impurities in either form of glass, metal or plastics above 2 mm;

(b) no more than 5 g/kg dry matter **of the sum** of macroscopic impurities ~~in the form of glass, metal and plastics above 2 mm~~ **referred to in point 4 (aa)**.

~~5. As of [Publications office: Please insert the date seven years occurring 5 years after the date of entry-into-force application of this Regulation], the compost **presence of plastics above 2mm within the maximum limit value referred to in point (b)** shall ~~be~~ contain no more than 2,5 g/kg dry matter of macroscopic impurities in the form of plastics above 2 mm. By [Publications office: Please insert the date occurring 8 ten years after the date of entry-into-force application of this Regulation] the limit-value of 2,5 g/kg dry matter **for plastics** shall be re-assessed in order to take into account the progress made with regards to separate collection of bio-waste.~~

³¹ Sum of naphthalene, acenaphthylene, acenaphthene, fluorene, phenanthrene, anthracene, fluoranthene, pyrene, benzo[a]anthracene, chrysene, benzo[b]fluoranthene, benzo[k]fluoranthene, benzo[a]pyrene, indeno[1,2,3-cd]pyrene, dibenzo[a,h]anthracene and benzo[ghi]perylene

6. The compost shall meet at least one of the following stability criteria:

(a) Oxygen uptake rate:

- Definition: an indicator of the extent to which biodegradable organic matter is being broken down within a specified time period. The method is not suitable for material with a content of particle sizes > 10 mm exceeding 20 %,
- Criterion: maximum 25 mmol O₂/kg organic matter/h; or

(b) Self heating factor:

- Definition: the maximum temperature reached by a compost in standardised conditions as an indicator of the state of its aerobic biological activity,
- Criterion: minimum Rottegrad III.

CMC 4: ~~ENERGY~~ FRESH CROP DIGESTATE

1. A ~~CE marked~~ EU fertilising product may contain digestate obtained through anaerobic digestion of exclusively one or more of the following input materials:

(a) Plants or plant parts grown for the production of biogas ~~that have not been used for any other purpose~~. For the purpose of this paragraph, plants are understood to include algae and exclude blue-green algae (cyanobacteria);

(b) Digestion additives which are needed to improve the process performance or the environmental performance of the digestion process provided that:

- the additive is registered pursuant to Regulation (EC) No 1907/2006³², in a dossier containing
 - the information provided for by Annex VI, VII and VIII of Regulation (EC) No 1907/2006, and
 - a chemical safety report pursuant to Article 14 of Regulation (EC) No 1907/2006 covering the use as fertilising product,

unless explicitly covered by one of the registration obligation exemptions provided for by Annex IV to that Regulation or by points 6, 7, 8, or 9 of Annex V to that Regulation, and

- the total concentration of all additives does not exceed 5 % of the total input material weight; or

(c) Any material referred to in points (a)-(b) that has previously been digested.

³² In the case of an additive recovered in the European Union, this condition is fulfilled if the additive is the same, within the meaning of Article 2(7)(d)(i) of Regulation (EC) No 1907/2006, as a substance registered in a dossier containing the information here indicated, and if information is available to the fertilising product manufacturer within the meaning of Article 2(7)(d)(ii) of Regulation (EC) No 1907/2006.

2. The anaerobic digestion shall take place in a plant
 - **in a separated production line** which only processes input materials referred to in paragraph 1 above, and
 - where physical contacts between input and output materials shall be avoided, including during storage.

3. The anaerobic digestion shall consist in controlled decomposition of biodegradable materials, which is predominantly anaerobic and at temperatures suitable for mesophilic or thermophilic bacteria. All parts of each batch shall be regularly and thoroughly moved **and turned** in order to ensure the correct sanitation and homogeneity of the material. During the digestion process, all parts of each batch shall have one of the following temperature-time profiles:
 - (a) Thermophilic anaerobic digestion at 55°C during at least 24h and **followed by** a hydraulic retention time of at least 20 days;
 - (b) Thermophilic anaerobic digestion at 55°C with a treatment process including a pasteurisation step (70°C – 1h);

- (c) Thermophilic anaerobic digestion at 55°C followed by composting in
- **70°C or more for at least 3 days,**
 - 65°C or more for at least 5 days,
 - 60°C or more for at least 7 days, or
 - 55°C or more for at least 14 days;
- (d) Mesophilic anaerobic digestion at 37-40°C with a treatment process including a pasteurisation step (70°C – 1h); or
- (e) Mesophilic anaerobic digestion at 37-40°C followed by composting in
- **70°C or more for at least 3 days,**
 - 65°C or more for at least 5 days,
 - 60°C or more for at least 7 days, or
 - 55°C or more for at least 14 days.

4. Both the solid and the liquid part of the digestate shall meet at least one of the following stability criteria:

(a) Oxygen uptake rate:

- Definition: an indicator of the extent to which biodegradable organic matter is being broken down within a specified time period. The method is not suitable for material with a content of particle sizes > 10 mm exceeding 20 %.
- Criterion: maximum ~~50~~ 25 mmol O₂/kg organic matter/h; or

(b) Residual biogas potential:

- Definition: an indicator of the gas released from a digestate in a 28 day period and measured against the volatile solids contained within the sample. The test is run in triplicate, and the average result is used to demonstrate compliance with the requirement. The volatile solids are those solids in a sample of material that are lost on ignition of the dry solids at 550°C.
- Criterion: maximum ~~0,45~~ 0,25 l biogas /g volatile solids.

CMC 5: OTHER DIGESTATE THAN ~~ENERGY~~ FRESH CROP DIGESTATE

1. A ~~CE~~-marked EU fertilising product may contain digestate obtained through anaerobic digestion of exclusively one or more of the following input materials:
 - (a) Bio-waste within the meaning of Directive 2008/98/EC resulting from separate bio-waste collection at source;
 - (b) **Products derived from** ~~A~~ animal by-products **referred to in Article 32** of categories ~~2 and 3~~ according to Regulation (EC) No 1069/2009 **for which the end point in the manufacturing chain has been determined in accordance with the third paragraph of Article 5(2) of that Regulation;**
 - (c) Living or dead organisms or parts thereof which are unprocessed or processed only by manual, mechanical or gravitational means, by dissolution in water, by flotation, by extraction with water, by steam distillation or by heating solely to remove water, or which are extracted from air by any means, except
 - the organic fraction of mixed municipal household waste separated through mechanical, physicochemical, biological and/or manual treatment,
 - sewage sludge, industrial sludge or dredging sludge,
 - animal by-products **or derived products** of category 1 according to **falling within the scope of** Regulation (EC) No 1069/2009 **for which no end point in the manufacturing chain has been determined in accordance with the third paragraph of Article 5(2) of that Regulation;**

(d) Digestion additives which are necessary to improve the process performance or the environmental performance of the digestion process provided that

- the additive is registered pursuant to Regulation (EC) No 1907/2006³³, in a dossier containing
 - the information provided for by Annex VI, VII and VIII of Regulation (EC) No 1907/2006, and
 - a chemical safety report pursuant to Article 14 of Regulation (EC) No 1907/2006 covering the use as fertilising product,

unless it is covered by the registration obligation exemption provided for by Annex IV to that Regulation or by points 6, 7, 8, or 9 of Annex V to that Regulation, and

- the total concentration of all additives does not exceed 5 % of the total input material weight; or

(e) Any material listed in points (a)- ~~to~~ (d) that

- has previously been composted or digested, and
- contains no more than 6 mg/kg dry matter of PAH₁₆³⁴.

³³ In the case of an additive recovered in the European Union, this condition is fulfilled if the additive is the same, within the meaning of Article 2(7)(d)(i) of Regulation (EC) No 1907/2006, as a substance registered in a dossier containing the information here indicated, and if information is available to the fertilising product manufacturer within the meaning of Article 2(7)(d)(ii) of Regulation (EC) No 1907/2006.

³⁴ Sum of naphthalene, acenaphthylene, acenaphthene, fluorene, phenanthrene, anthracene, fluoranthene, pyrene, benzo[a]anthracene, chrysene, benzo[b]fluoranthene, benzo[k]fluoranthene, benzo[a]pyrene, indeno[1,2,3-cd]pyrene, dibenzo[a,h]anthracene and benzo[ghi]perylene

2. The anaerobic digestion shall take place in a plant
 - **in a separated production line** which only processes input materials referred to in paragraph 1 above, and
 - where physical contacts between input and output materials shall be avoided, including during storage.

3. The anaerobic digestion shall constitute of controlled decomposition of biodegradable materials, which is predominantly anaerobic and at temperatures suitable for mesophilic or thermophilic bacteria. All parts of each batch shall be regularly and thoroughly moved **and turned** in order to ensure the correct sanitation and homogeneity of the material. During the digestion process, all parts of each batch shall have one of the following temperature-time profiles:
 - (a) Thermophilic anaerobic digestion at 55°C during at least 24h ~~and~~ **followed by** a hydraulic retention time of at least 20 days;
 - (b) Thermophilic anaerobic digestion at 55°C with a treatment process including a pasteurisation step (70°C – 1h);
 - (c) Thermophilic anaerobic digestion at 55°C followed by composting in
 - **70°C or more for at least 3 days,**
 - 65°C or more for at least 5 days,
 - 60°C or more for at least 7 days, or
 - 55°C or more for at least 14 days;

(d) Mesophilic anaerobic digestion at 37-40°C with a treatment process-including a pasteurisation step (70°C – 1h); or

(e) Mesophilic anaerobic digestion at 37-40°C followed by composting in

- **70°C or more for at least 3 days,**

- 65°C or more for at least 5 days,

- 60°C or more for at least 7 days, or

- 55°C or more for at least 14 days.

4. Neither the solid, nor the liquid part of the digestate shall contain more than 6 mg/kg dry matter of PAH₁₆³⁵.

5. The digestate shall contain:

(a) no more than 3 g/kg dry matter of macroscopic impurities in either form of glass, metal or plastics above 2 mm;

(b) no more than 5 g/kg dry matter of the sum of macroscopic impurities in the form of glass, metal and plastics above 2 mm referred to in point 5 (a).

³⁵ Sum of naphthalene, acenaphthylene, acenaphthene, fluorene, phenanthrene, anthracene, fluoranthene, pyrene, benzo[a]anthracene, chrysene, benzo[b]fluoranthene, benzo[k]fluoranthene, benzo[a]pyrene, indeno[1,2,3-cd]pyrene, dibenzo[a,h]anthracene and benzo[ghi]perylene

6. As of [Publications office: Please insert the date ~~occurring 5 years~~ **seven years** after the **entry-into-force** ~~date of application~~ of this Regulation], the digestate **presence of plastics above 2 mm in the maximum limit value referred to in point 5** shall ~~contain~~ **be** no more than 2,5 g/kg dry matter ~~of macroscopic impurities in the form of plastics above 2 mm~~. By [Publications office: Please insert the date ~~occurring 8 years~~ **ten years** after the ~~date of application~~ **entry-into-force** of this Regulation] the limit-value of 2,5 g/kg dry matter **for plastics** shall be re-assessed in order to take into account the progress made with regards to separate collection of bio-waste.
7. Both the solid and the liquid part of the digestate shall meet at least one of the following stability criteria:
- (a) Oxygen uptake rate:
- Definition: an indicator of the extent to which biodegradable organic matter is being broken down within a specified time period. The method is not suitable for material with a content of particle sizes > 10 mm exceeding 20 %.
 - Criterion: maximum ~~50~~ **25** mmol O₂/kg organic matter/h; or
- (b) Residual biogas potential:
- Definition: an indicator of the gas released from a digestate in a 28 day period and measured against the volatile solids contained within the sample. The test is run in triplicate, and the average result is used to demonstrate compliance with the requirement. The volatile solids are those solids in a sample of material that are lost on ignition of the dry solids at 550°C.
 - Criterion: maximum ~~0,45~~ **0,25** l biogas /g volatile solids.

CMC 6: FOOD INDUSTRY BY-PRODUCTS

1. A ~~CE marked~~ EU fertilising product may contain component material consisting of one of the following substances:
 - (a) food industry factory lime, i.e. a material from the food processing industry obtained by carbonation of organic matter, using exclusively burnt lime from natural sources;
 - (b) molasses, i.e. a viscous by-product of the refining of sugarcane or sugar beets into sugar; or
 - (c) vinasse, i.e. a viscous by-product of the fermentation process of molasses into ethanol, ascorbic acid or other products;

(ca) distillers grains, i.e. by-products resulting from the production of beer-alcoholic beverages;

(cb) plants, plant parts or plant extracts having undergone only heat treatment or heat treatment in addition to processing methods referred to in CMC2 or heat treatment;

(cc) lime from drinking water production, i.e. residue which is released by production of drinking water from groundwater or surface water and consists, mainly, of calcium carbonate.

2. All ~~the~~ substances incorporated into the EU fertilising product, in their own or in a mixture, shall have been registered pursuant to Regulation (EC) No 1907/2006³⁶, in a dossier containing

- (a) the information provided for by Annex VI, VII and VIII of Regulation (EC) No 1907/2006, and
- (b) a chemical safety report pursuant to Article 14 of Regulation (EC) No 1907/2006 covering the use as fertilising product,

unless explicitly covered by one of the registration obligation exemptions provided for by Annex IV to that Regulation or by points 6, 7, 8, or 9 of Annex V to that Regulation.

³⁶ In the case of a substance recovered in the European Union, this condition is fulfilled if the substance is the same, within the meaning of Article 2(7)(d)(i) of Regulation (EC) No 1907/2006, as a substance registered in a dossier containing the information here indicated, and if information is available to the fertilising product manufacturer within the meaning of Article 2(7)(d)(ii) of Regulation (EC) No 1907/2006.

CMC 7: MICRO-ORGANISMS

A ~~CE~~-marked EU fertilising product **belonging to PFC 6(A)** may contain micro-organisms, including dead or empty-cell micro-organisms and non-harmful residual elements of the media on which they were produced, which

- have undergone no other processing than drying or freeze-drying and
- are listed in the table below

<i>Azotobacter spp.</i>
<i>Mycorrhizal fungi</i>
<i>Rhizobium spp.</i>
<i>Azospirillum spp.</i>

CMC 8: AGRONOMIC ADDITIVES

1. — A CE marked EU fertilising product may contain a substance or a mixture intended to improve the fertilising product's nutrient release patterns, only if that substance's or mixture's compliance with the requirements of this Regulation for a product in PFC 5 of Annex I has been demonstrated in accordance with the conformity assessment procedure applicable to such an agronomic additive.
2. — The quantity of the compliant agronomic additive in the CE marked EU fertilising product shall be such as
 - (a) — to produce the effect claimed in the information provided to the user of the CE marked EU fertilising products, and
 - (b) — not to cause an overall adverse effect on human, animal or plant health, on safety, or on the environment, under reasonably foreseeable conditions of storage or use of the CE marked EU fertilising product.
3. — A CE marked EU fertilising product may contain a compliant nitrification inhibitor, as referred to in PFC 5(A)(I) of Annex I, only if at least 50% of the total nitrogen (N) content of the fertilising product consists of the nitrogen (N) forms ammonium (NH_4^+) and urea ($\text{CH}_4\text{N}_2\text{O}$).

4. ~~A CE marked EU fertilising product may contain a compliant urease inhibitor, as referred to in PFC 5(BA)(II) of Annex I, only if at least 50% of the total nitrogen (N) content of the fertilising product consists of the nitrogen (N) form urea ($\text{CH}_4\text{N}_2\text{O}$).~~
5. ~~The manufacturer of the CE marked EU fertilising product shall be in possession of the EU declaration of conformity of the compliant agronomic additive.~~
6. ~~Economic operators making the CE marked EU fertilising product available on the market shall respect the following provisions of this Regulation with regard to the EU declarations of conformity of both the CE marked EU fertilising product and the compliant agronomic additive:~~
- ~~(a) Article 6(3) (manufacturers' obligation to keep the EU declaration of conformity);~~
 - ~~(b) Article 7(2)(a) (authorised representatives' obligation to keep the EU declaration of conformity);~~
 - ~~(c) Article 8(2) (importers' obligation to ensure that the CE marked EU fertilising product is accompanied by the EU declaration of conformity);~~
 - ~~(d) Article 8(8) (importers' obligation to keep a copy of the EU declaration of conformity at the disposal of the market surveillance authorities); and~~
 - ~~(e) Article 9(2) (distributors' obligation to verify that the CE marked EU fertilising product is accompanied by the EU declaration of conformity).~~

CMC 9: NUTRIENT POLYMERS

1. A ~~CE marked~~ **EU** fertilising product may contain polymers exclusively made up of monomer substances complying with the ~~description~~ **criteria set out in points 1 and 2 of** in CMC 1, where the purpose of the polymerisation is to control the release of nutrients from one or more of the monomer substances.
2. At least 3/5 of the polymers shall be soluble in **phosphate buffer solution with pH 7,5 at 100 °C.** ~~hot water.~~
- 2a. The final degradation products shall be only ammonium (NH₃), water and carbon dioxide (CO₂).**
3. The polymers shall not contain **more than 0,01%** of **free** formaldehyde.

CMC 10: OTHER POLYMERS THAN NUTRIENT POLYMERS

1. A ~~CE marked~~ EU fertilising product may contain other polymers than nutrient polymers only in cases where the purpose of the polymer is that of
 - (a) controlling the water penetration into nutrient particles and thus the release of nutrients (in which case the polymer is commonly referred to as a 'coating agent'), or
 - (b) increasing the water retention capacity or wettability of the ~~CE marked~~ EU fertilising product, or
 - (c) binding material in a CE marked fertilising product belonging to PFC 4, (growing medium).**
- 1a. The requirements of paragraphs 2 and 3 shall apply only for the polymers referred to in points a) and b) of paragraph 1.**
2. As of [Publications office, please insert the date occurring ~~three~~ seven years after the date of entry-into-force application of this Regulation], the polymers shall comply with the biodegradability criteria adopted by the Commission in accordance with Article 42(4a). No polymers referred to in points a) or b) of paragraph 1 may be contained in EU fertilising products placed on the market after that date without complying with such a delegated act. following criterion shall be complied with: The polymer shall be capable of undergoing physical, biological decomposition, such that most of it ultimately decomposes into carbon dioxide (CO₂), biomass and water. It shall have at least 90 % of the organic carbon converted into CO₂ in maximum 24 months **after the end of the functionality period indicated in accordance with point 2 (cb) of Part I of Annex III,** in a biodegradability test as specified points (a)-(c) below.

If by [Publications office, please insert the date occurring five years after the date of entry into force of this Regulation] the Commission has not adopted such criteria, a EU fertilising product must not contain polymers referred to in points a) and b) of paragraph 1.

- (a) ~~The test shall be conducted at $25^{\circ}\text{C} \pm 2^{\circ}\text{C}$.~~
- (b) ~~The test shall be conducted in accordance with a method for determining the ultimate aerobic biodegradability of plastic materials in soils by measuring oxygen demand or the amount of carbon dioxide evolved.~~
- (c) ~~A micro-crystalline cellulose powder with the same dimension as the test material shall be used as a reference material in the test.~~
- (d) ~~Prior to the test, the test material shall not be subject to conditions or procedures designed to accelerate the degradation of the film, such as exposure to heat or light.~~

3. Neither the polymer, nor its degradation by-products, shall show any overall adverse effect on animal or plant health, or on the environment, under reasonably foreseeable conditions of use in the ~~CE-marked~~ **EU** fertilising product. The polymer shall pass a plant growth acute toxicity test, an earthworm acute toxicity test and a nitrification inhibition test with soil micro-organisms as follows:

(a) In the plant growth acute toxicity test, the germination rate and the plant biomass of the tested plant species grown on the soil exposed to the test material shall be more than 90 % of the germination rate and the plant biomass of the same plant species grown on corresponding blank soil not exposed to the test material.

~~(b)~~—The results shall be considered **to be** valid only if in the controls (i.e. blank soil):

- the seedling emergence is at least 70 %;
- the seedlings do not exhibit visible phytotoxic effects (e.g. chlorosis, necrosis, wilting, leaf and stem deformations) and the plants exhibit only normal variation in growth and morphology for that particular species;
- the mean survival of emerged control seedlings is at least 90 % for the duration of the study; and
- environmental conditions for a particular species are identical and growing media contain the same amount of soil matrix, support media, or substrate from the same source.

- (c) In the earthworm acute toxicity test, the observed mortality and the biomass of surviving earthworms in a soil exposed to the test material shall not differ by more than 10 % compared to those from the corresponding blank soil not exposed to the test material. The results shall be considered to be valid, if
- the percent mortality observed in the control (i.e. blank soil) is < 10 %, and
 - the average loss of biomass (mean weight) of the worms in the blank soil does not exceed 20 %.
- (d) In the nitrification inhibition test with soil micro-organisms, the nitrite formation in soil exposed to the test material shall be more than 90 % of those from the corresponding blank soil not exposed to the test material. The results shall be considered to be valid, if the variation between replicate control samples (blank soil) and test samples is less than ± 20 %.

CMC 11: CERTAIN PRODUCTS DERIVED FROM ANIMAL BY-PRODUCTS

A ~~CE-marked~~ **EU** fertilising product may contain **products derived from** animal by-products within the meaning of Regulation (EC) No 1069/2009 having reached the end point in the manufacturing chain as determined in accordance with that Regulation, **and** which are listed in the table below and as specified therein:

Labelling requirements

This Annex sets out the labelling requirements for ~~CE-marked~~ **EU** fertilising products. The requirements laid down in Part 2 and Part 3 of this Annex for a given Product Function Category ('PFC'), as specified in Annex I, apply to ~~CE-marked~~ **EU** fertilising products in all subcategories of that PFC.

PART 1

GENERAL LABELLING REQUIREMENTS

- ~~1. The information elements required by this Regulation shall be clearly separated from any other information elements.~~
2. The following information elements shall be provided:
 - (a) **For products in** ~~The designation of the Product Function Category ('PFC') 1-6,~~ **the designation** as indicated in Part I of Annex I **of the PFC corresponding to the product's claimed function;**
 - (aa) For products in PFC 7, the designation as indicated in Part I of Annex I of all the PFCs corresponding to the claimed functions of the component fertilising products;**
 - (b) The quantity of the ~~CE-marked~~ **EU** fertilising product, indicated by mass or volume;
 - (c) Instructions for intended use, including intended application rate, **timing and frequency,** and intended target plants **or mushrooms;**

(ca) recommended storage conditions

(cb) For products containing a polymer belonging to CMC 10, the time period following use during which the nutrient release is being controlled or the water retention capacity is being increased (the 'functionality period'), which shall not be longer than the period between two applications in accordance with the use instructions mentioned in point (c);

(d) Any relevant information on measures recommended to manage risks to ~~human, animal or plant health, safety, or the environment~~; and

(e) ~~A a list~~ description of all **ingredients** components above 5% by product weight in descending order of magnitude by dry weight, including an indication of the relevant component material categories ('CMC') as referred to in Annex II; **where the component ingredient is a substance or a mixture, it shall be identified as specified in Article 18 of Regulation (EC) No 1272/2008.**

3. ~~Where the conformity assessment procedure has involved a notified body, the identification number of the notified body shall be indicated.~~

4. Where the ~~CE marked~~ **EU** fertilising product contains **products derived from** animal by-products within the meaning of Regulation (EC) No 1069/2009 other than manure, it shall carry the following user instruction: 'Farmed animals shall not be fed, either directly or by grazing, with herbage from land to which the product has been applied unless the cutting or grazing takes place after the expiry of a waiting period of at least 21 days.'
5. Where the ~~CE marked~~ **EU** fertilising product contains a substance for which maximum residue limits for food and feed have been established in accordance with Regulation (EEC) No 315/93, Regulation (EC) No 396/2005, Regulation (EC) No 470/2009 or Directive 2002/32/EC, the instructions referred to in paragraph 2(c) shall ensure that the intended use of the ~~CE marked~~ **EU** fertilising product does not lead to the exceedance of those limits in food or feed.
6. Where an EU fertilising product has functions described in two or more of the ~~The designation of a product function categories~~ ('PFC'), **laid down** as indicated in Annex I, **only those PFCs for which the** ~~must not be indicated on a CE marked EU fertilising product which has not been subject of a successful conformity assessment in accordance with this Regulation~~ **may be claimed by using the PFC designations of Annex I** for that PFC.
- 6a. Where the EU fertilising product contains ricin, the following instruction shall be provided on the label: "Hazardous to animals in case of ingestion".**
- 6b. Where the EU fertilising product contains unprocessed or processed cocoa shells, the following instruction shall be provided on the label: "Toxic to dogs and cats".**

7. Information elements other than those required under paragraphs 2-6
- (a) shall not mislead the user, for example by attributing to the product properties that it does not possess, or by suggesting that the product possesses unique characteristics which similar products also have;
 - (b) shall relate to verifiable factors; and
 - (c) shall not make claims such as 'sustainable' or 'environmentally friendly' unless such claims **refer to legislation, guidelines** ~~can be objectively verified against widely recognised guidance, standards or schemes,~~ **with which they comply**.
8. The phrase 'poor in chloride' or similar may only be used if the chloride (Cl-) content is below 30 g/kg **of dry matter**.

8a. Where the nutrient content information requirements in this Annex are expressed in oxidised form, the nutrient content may be expressed in elemental form instead or in addition to the oxidised form in accordance with the following conversion factors:

phosphorus (P) = phosphorus pentoxide (P₂O₅) × 0,436;

potassium (K) = potassium oxide (K₂O) × 0,830;

calcium (Ca) = calcium oxide (CaO) × 0,715;

magnesium (Mg) = magnesium oxide (MgO) × 0,603;

sodium (Na) = sodium oxide (Na₂O) × 0,742;

sulphur (S) = sulphur trioxide (SO₃) × 0,400.

8b. Where the information requirements in this Annex refer to the organic carbon (C_{org}) the information may refer to the organic matter instead or in addition to the organic carbon (C_{org}), in accordance with the following conversion factor :

C_{org} = organic matter × 0,56.

8c. Where the EU fertilising product contains total chromium (Cr) above 200 mg/kg, information about the maximum quantity and exact source of total chromium (Cr) shall be given.

9. Where the EU fertilising product contains a polymer with the purpose of binding material in the product, as referred to in paragraph (c) of point 1 of CMC 10 in Annex II, the user shall be instructed not to use the product in contact with soil, and in collaboration with the manufacturer, make sure of a sound disposal of the products after end of use.

PART 2

PRODUCT-SPECIFIC LABELLING REQUIREMENTS

PFC 1: FERTILISER

1. The content of ~~nitrogen (N) or, phosphorus (P) and potassium (K)~~ **nutrients** shall be declared only where ~~those nutrients~~ **they** are present in the ~~CE marked~~ **EU** fertilising product in the minimum quantity specified in Annex I for the relevant product function category (PFC).

1a. The content of nitrogen (N) and phosphorus pentoxide (P₂O₅), if above 0,5 % by mass, shall be declared.

2. The following rules apply to fertilisers containing ~~nitrification or urease~~ inhibitors, as specified in ~~paragraphs 3 and 4~~ of component material category ('CMC') ~~8-1~~ in Annex II:
 - (a) The label shall state the words "nitrification inhibitor", ~~or~~ "urease inhibitor" **or** **"denitrification inhibitor"**, as relevant, ~~as well as the identification number of the notified body having examined the conformity assessment of the nitrification inhibitor or the urease inhibitor.~~
 - (b) The nitrification inhibitor content shall be expressed as a percentage by mass of the total nitrogen (N) present as ammonium nitrogen (NH₄⁺) and urea nitrogen (CH₄N₂O).
 - (c) The urease inhibitor content shall be expressed as a percentage by mass of the total nitrogen (N) present as urea nitrogen (CH₄N₂O).
 - (ca) The denitrification inhibitor content shall be expressed as a percentage by mass of the nitrate (NO₃⁻) present.**
 - ~~(d) Technical information shall be provided enabling the user to determine the rates and timing of application in relation to the crop being grown.~~

3. The term "mineral fertiliser" may be used only if the fertiliser belongs to PFC 1(C) and fulfils the following additional conditions:

(a) The mineral fertiliser must not contain more than 1 % by mass of organic carbon (Corg), other than organic carbon from

- chelating or complexing agents referred to in point 2a of CMC 1, from**
- nitrification inhibitors, urease inhibitors or denitrification inhibitors referred to in point 2b of CMC 1, from**
- coating agents referred to in point 1(a) of CMC 10, from**
- urea, or from**
- calcium cyanamide.**

(b) Where phosphorus (P) is a declared nutrient, the declared phosphorus shall consist only of phosphorus in the phosphatic form, and the mineral fertiliser shall fulfil at least one of the following solubility criteria:

- Water solubility: minimum level 40% of total phosphorus (P), or**
- Solubility in neutral ammonium citrate: minimum level 75% of total phosphorus (P), or**
- Solubility in formic acid (only for soft rock phosphate): minimum level 55% of total phosphorus (P).**

(c) Where nitrogen (N) is a declared nutrient, the declared nitrogen content shall consist only of the sum of nitric nitrogen, ammoniacal nitrogen, ureic nitrogen, and nitrogen from methylene-urea, from isobutylidenediurea, and from crotonylidenediurea.

PFC 1(A): Organic fertiliser

The following information elements shall be present:

- (a) the declared nutrients nitrogen (N), phosphorus (P) or potassium (K), by their chemical symbols in the order N-P-K;
- (b) the declared nutrients magnesium (Mg), calcium (Ca), sulphur (S) or sodium (Na), by their chemical symbols in the order ~~Mg-Ca-S-Na~~ **Ca-Mg-Na-S**;
- (c) numbers indicating the ~~total~~ content of the declared nutrients **total** nitrogen (N), **total** phosphorus **in the form of phosphorus pentoxide** (P_2O_5) or **total** potassium **in the form of potassium oxide** (K_2O), followed by numbers in brackets indicating the total content of **calcium oxide** (CaO) ~~magnesium~~ **oxide** (MgO), ~~calcium~~ **oxide** (CaO), **sodium oxide** (Na_2O) ~~or~~ sulphur **trioxide** (SO_3) ~~or sodium~~ **oxide** (Na_2O);

(d) the content of the following declared nutrients and other parameters, in the following order and as a percentage of the fertiliser % by mass,

- Total Nitrogen (N)
 - minimum amount of organic nitrogen (N_{org}), followed by a description of the origin of the organic matter used;
 - Nitrogen (~~N~~) in the form of ammoniacal nitrogen;
- Total phosphorus pentoxide (P_2O_5);
- Total potassium oxide (K_2O);
- **Calcium oxide (CaO)**, ~~M~~magnesium oxide (MgO), ~~calcium oxide (CaO)~~, sulphur ~~trioxide (SO_3)~~ and sodium oxide (Na_2O) **and sulphur trioxide (SO_3)**, expressed
 - where those nutrients are totally soluble in water, only as the content soluble in water;
 - where the soluble content of those nutrients is at least a quarter of the total content of those nutrients, the total content and the content soluble in water; and
 - in other cases, as the total content;
- ~~Total copper (Cu) and zinc (Zn), if above 200 and 600 mg/kg dry matter respectively;~~
- Organic carbon (C_{org}); and
- Dry matter.

(da) the ratio of organic carbon to total nitrogen (C_{org}/N)

(db) Production date

PFC 1(B): Organo-mineral fertiliser

1. The following information elements ~~relating to macronutrients~~ shall be present:
 - (a) the declared nutrients nitrogen (N), phosphorus (P) or potassium (K), by their chemical symbols in the order N-P-K;
 - (b) **where applicable**, the declared nutrients magnesium (Mg), calcium (Ca), sulphur (S) or sodium (Na), by their chemical symbols in the order ~~Mg-Ca-S-Na~~ **Ca-Mg-Na-S**;
 - (c) numbers indicating the ~~total~~ content of the declared nutrients **total** nitrogen (N), **total** phosphorus **in the form of phosphorus pentoxide** (P₂O₅) or **total** potassium **in the form of potassium oxide** (K₂O), followed by numbers in brackets indicating the total content of **calcium oxide (CaO)**, magnesium **oxide** (MgO), ~~calcium **oxide** (CaO)~~, **sodium oxide (Na₂O)** or sulphur **trioxide** (SO₃) ~~or sodium **oxide** (Na₂O)~~;

(d) the content of the following declared nutrients **and other parameters**, in the following order and as a percentage of the fertiliser **%** by mass:

- Total Nitrogen (N)
 - minimum amount of organic nitrogen (N_{org}), followed by a description of the origin of the organic matter used;
 - Nitrogen (~~N~~) in the form of nitric nitrogen;
 - Nitrogen (~~N~~) in the form of ammoniacal nitrogen;
 - Nitrogen (~~N~~) in the form of urea nitrogen;
- Total phosphorus pentoxide (P_2O_5);
 - Water-soluble phosphorus pentoxide (P_2O_5);
 - phosphorus pentoxide (P_2O_5) soluble in neutral ammonium citrate;
 - where soft ground phosphate is present, phosphorus pentoxide (P_2O_5) soluble in formic acid;
- Total potassium oxide (K_2O);
 - Water soluble potassium oxide (K_2O);

- **Calcium oxide (CaO)**, magnesium oxide (MgO), ~~calcium oxide (CaO)~~, **sodium oxide (Na₂O) and** sulphur trioxide (SO₃) ~~and sodium oxide (Na₂O)~~, expressed
 - where those nutrients are totally soluble in water, only as the content soluble in water;
 - where the soluble content of those nutrients is at least a quarter of the total content of those nutrients, the total content and the content soluble in water;
 - in other cases, as the total content, ~~and~~

- **Organic carbon (C_{org}) content;**

- **Dry matter content, and**

- (e) where urea (CH₄N₂O) is present, information about the possible air quality impacts of the release of ammonia from the fertiliser use, and an invitation to users to apply appropriate remediation measures.

~~2. The following other elements shall be indicated as a percentage by mass of the CE marked EU fertilising product:~~

- ~~• Organic carbon (C_{org}) content; and~~
- ~~• Dry matter content.~~

PFC 1(B)(I): Solid organo-mineral fertiliser

2a. Where one or more of the micronutrients boron (B), cobalt (Co), ~~copper (Cu)~~, iron (Fe), manganese (Mn), **and** molybdenum (Mo) ~~and zinc (Zn)~~, are present in the minimum content indicated as a ~~percentage~~ **%** by mass in the table below, they

- shall be declared if they are intentionally added to the ~~CE marked~~ **EU** fertilising product, and
- may be declared in other cases:

Micronutrient	Content of micronutrient (% by mass)		
	Solid organo-mineral fertiliser		Liquid organo-mineral fertiliser
	Intended for use on crops or grassland	Intended for horticultural use	
Boron (B)	0,01	0,01	0,01
Cobalt (Co)	0,002	n.a.	0,002
Copper (Cu)	0,01	0,002	0,002
Iron (Fe)	0,5	0,02	0,02
Manganese (Mn)	0,1	0,01	0,01
Molybdenum (Mo)	0,001	0,001	0,001
Zinc (Zn)	0,01	0,002	0,002

2b. Where one or both of the micronutrients copper (Cu) and zinc (Zn), are present, without being intentionally added, in the minimum content indicated as % by mass in the table below, they may be declared:

<u>Micronutrient</u>	<u>Content of micronutrient (% by mass)</u>		
	<u>Solid organo-mineral fertiliser</u>		<u>Liquid organo-mineral fertiliser</u>
	<u>Intended for use on crops or grassland</u>	<u>Intended for horticultural use</u>	
<u>Copper (Cu)</u>	<u>0,01</u>	<u>0,002</u>	<u>0,002</u>
<u>Zinc (Zn)</u>	<u>0,01</u>	<u>0,002</u>	<u>0,002</u>

2c. Where copper (Cu) or zinc (Zn) is intentionally added to the organo-mineral fertiliser the total content of copper (Cu) or zinc (Zn) shall be declared.

2d. Micronutrients referred to in points 2a to 2c They shall be declared after the information on macronutrients. The following information elements shall be present:

- (a) indication of the names and chemical symbols of the declared micronutrients, listed in the following order: boron (B), cobalt (Co), copper (Cu), iron (Fe), manganese (Mn), molybdenum (Mo) and zinc (Zn), followed by the name(s) of their counter-ion(s);
- (b) The total micronutrient content expressed as a ~~percentage of the fertiliser~~ % by mass
 - where those nutrients are totally soluble in water, only as the content soluble in water;
 - where the soluble content of those nutrients is at least a quarter of the total content of those nutrients, the total content and the content soluble in water; and
 - in other cases, as the total content;

- (c) Where the declared micronutrient(s) are chelated by chelating agent(s), the following qualifier after the name and the chemical identifier of the micronutrient:
- ‘chelated by...’ name of the chelating agent or its abbreviation, and the amount of chelated micronutrient as ~~a percentage of the CE marked~~ **EU fertilising product %** by mass;
- (d) Where the ~~CE marked~~ **EU** fertilising product contains micronutrient(s) complexed by complexing agent(s) **the following qualifier after the name and the chemical identifier of the micronutrient:**
- ~~the following qualifier after the name and the chemical identifier of the micronutrient:~~ ‘complexed by ...’ **name of the complexing agent or its abbreviation**, and the amount of complexed micronutrient as ~~a percentage of the CE marked~~ **EU fertilising product %** by mass; and
 - ~~the name of the complexing agent or its abbreviation.~~
- (e) **In case micronutrients are intentionally added present,** ~~T~~the following statement: ‘To be used only where there is a recognised need. Do not exceed the ~~appropriate~~ **application** rate’.

PFC 1(B)(II): Liquid organo-mineral fertiliser

Where one or more of the micronutrients boron (B), cobalt (Co), copper (Cu), iron (Fe), manganese (Mn), molybdenum (Mo) and zinc (Zn), are present in the minimum content indicated as a percentage by mass in the table below, they

- shall be declared if they are intentionally added to the CE marked EU fertilising product, and
- may be declared in other cases:

Micronutrient	Percentage by mass
Boron (B)	0,01
Cobalt (Co)	0,002
Copper (Cu)	0,002
Iron (Fe)	0,02
Manganese (Mn)	0,01
Molybdenum (Mo)	0,001
Zinc	0,002

They shall be declared after the information on macronutrients. The following information elements shall be present:

- (a) indication of the names and chemical symbols of the declared micronutrients, listed in the following order: boron (B), cobalt (Co), copper (Cu), iron (Fe), manganese (Mn), molybdenum (Mo) and zinc (Zn), followed by the name(s) of their counter-ion(s);

- (b) ~~The total micronutrient content expressed as a percentage of the fertiliser % by mass~~
- ~~— where those nutrients are totally soluble in water, only as the content soluble in water;~~
 - ~~— where the soluble content of those nutrients is at least a quarter of the total content of those nutrients, the total content and the content soluble in water; and~~
 - ~~— in other cases, as the total content;~~
- (c) ~~Where the declared micronutrient(s) are chelated by chelating agent(s), the following qualifier after the name and the chemical identifier of the micronutrient:~~
- ~~— ‘chelated by...’ name of the chelating agent or its abbreviation, and the amount of chelated micronutrient as a percentage of the CE marked EU fertilising product by mass;~~
- (d) ~~Where the CE marked EU fertilising product contains micronutrient(s) complexed by complexing agent(s):~~
- ~~— the following qualifier after the name and the chemical identifier of the micronutrient: ‘complexed by ...’, and the amount of complexed micronutrient as a percentage of the CE marked EU fertilising product by mass; and~~
 - ~~— the name of the complexing agent or its abbreviation.~~
- (e) ~~The following statement: ‘To be used only where there is a recognised need. Do not exceed the appropriate rate’.~~

PFC 1(C): Inorganic fertiliser

PFC 1(C)(I): Inorganic macronutrient fertiliser

1. The following information elements relating to macronutrients shall be present:
 - (a) **where applicable**, the declared nutrients nitrogen (N), phosphorus (P) or potassium (K), by their chemical symbols in the order N-P-K;
 - (b) **where applicable**, the declared nutrients magnesium (Mg), calcium (Ca), sulphur (S) or sodium (Na), by their chemical symbols in the order ~~Mg-Ca-S-Na~~ **Ca-Mg-Na-S**;
 - (c) numbers indicating the ~~total~~ content of the declared nutrients **total** nitrogen (N), **total** phosphorus **in the form of phosphorus pentoxide** (P₂O₅) or **total** potassium **in the form of potassium oxide** (K₂O), followed by numbers in brackets indicating the total content of **calcium oxide (CaO)**, magnesium **oxide** (MgO), ~~calcium oxide (CaO)~~, **sodium oxide (Na₂O)** or sulphur **trioxide** (SO₃) or ~~sodium oxide (Na₂O)~~;
 - (d) the content of the following declared nutrients, in the following order and as a ~~percentage of the fertiliser~~ **%** by mass,
 - Total Nitrogen (N);
 - Nitrogen (~~N~~) in the form of nitric nitrogen
 - Nitrogen (~~N~~) in the form of ammoniacal nitrogen;
 - Nitrogen (~~N~~) in the form of urea nitrogen;
 - Nitrogen (~~N~~) from urea formaldehyde, isobutylidenediurea, crotonylidenediurea;
 - Nitrogen (~~N~~) from cyanamide nitrogen;

- Total phosphorus pentoxide (P_2O_5);
 - Water-soluble phosphorus pentoxide (P_2O_5);
 - phosphorus pentoxide (P_2O_5) soluble in neutral ammonium citrate;
 - where soft ground phosphate is present, phosphorus pentoxide (P_2O_5) soluble in formic acid;
 - Water soluble potassium oxide (K_2O);
 - **calcium oxide (CaO)**, magnesium oxide (MgO), ~~calcium oxide (CaO)~~, **sodium oxide (Na₂O)** and sulphur trioxide (SO_3) ~~and sodium oxide (Na₂O)~~, expressed
 - where those nutrients are totally soluble in water, only as the content soluble in water;
 - where the soluble content of those nutrients is at least a quarter of the total content of those nutrients, the total content and the content soluble in water; and
 - in other cases, as the total content, and
- (e) where urea (CH_4N_2O) is present, information about the possible air quality impacts of the release of ammonia from the fertiliser use, and an invitation to users to apply appropriate remediation measures.

PFC 1(C)(I)(a): Solid inorganic macronutrient fertiliser

1. The fertiliser ~~shall~~ **may** be labelled
 - (a) ~~'complex' **only**, where **if**~~ each ~~particle~~ **physical unit** contains all the declared nutrients in their declared content, ~~and~~
 - (b) ~~'mix' in other cases.~~
2. The granulometry of the fertiliser shall be indicated, expressed a percentage of product passing through a determined sieve.
3. The ~~particle~~ **physical unit** form of the product shall be indicated with one of the following mentions:
 - (a) Granule,
 - (b) pellet,
 - (c) powder, where at least 90% of the product can pass through a sieve with a mesh of 10 mm, or
 - (d) prill.

4. For coated fertilisers, the name of the coating agent(s) and the percentage of fertilisers coated by each coating agent(s) shall be indicated and followed by:
- ~~(a) Release time defined in months of the coated fraction(s) followed by the percentage of nutrients released during this time for each fraction;~~
 - ~~(b) The name of the medium (solvent or substrate) used in the test performed by the manufacturer for determining the release time;~~
 - ~~(c) The temperature at which the test was conducted;~~
 - (d) For polymer coated fertilisers, the following marking: ‘The rate of nutrient releases can vary according to the temperature of the substrate. An adjustment of fertilisation may be necessary’; and
 - (e) For sulphur (S) coated fertilisers and sulphur (S)/polymer coated fertilisers, the following marking: ‘The rate of nutrient release can vary according to the temperature of the substrate and the biological activity. An adjustment of fertilisation may be necessary’.

5. Where one or more of the micronutrients boron (B), cobalt (Co), ~~copper (Cu)~~, iron (Fe), manganese (Mn), **and** molybdenum (Mo) ~~and zinc (Zn)~~, are present in the minimum content indicated below as a ~~percentage~~ **%** by mass, they

- shall be declared if they are intentionally added to the ~~CE marked~~ **EU** fertilising product, and
- may be declared in other cases:

Micronutrient	Content of micronutrients (% by mass)	
	Intended for use on crops or grassland	Intended for horticultural use
Boron (B)	0,01	0,01
Cobalt (Co)	0,002	n.a.
Copper (Cu)	0,01	0,002
Iron (Fe)	0,5	0,02
Manganese (Mn)	0,1	0,01
Molybdenum (Mo)	0,001	0,001
Zinc (Zn)	0,01	0,002

5a. Where one or both of the micronutrients copper (Cu) and zinc (Zn), are present, without being intentionally added, in the minimum content indicated as % by mass in the table below, they may be declared:

<u>Micronutrient</u>	<u>Content of micronutrients (% by mass)</u>	
	<u>Intended for use on crops or grassland</u>	<u>Intended for horticultural use</u>
<u>Copper (Cu)</u>	<u>0,01</u>	<u>0,002</u>
<u>Zinc (Zn)</u>	<u>0,01</u>	<u>0,002</u>

5b. Where copper (Cu) or zinc (Zn) is intentionally added to the solid inorganic macronutrient fertiliser the total content of copper (Cu) or zinc (Zn) shall be declared.

5c. Micronutrients referred to in points 5, 5a and 5b They shall be declared after the information on macronutrients. The following information elements shall be present:

- (a) indication of the names and chemical symbols of the declared micronutrients, listed in the following order: boron (B), cobalt (Co), copper (Cu), iron (Fe), manganese (Mn), molybdenum (Mo) and zinc (Zn), followed by the name(s) of their counter-ion(s);
- (b) The total micronutrient content expressed as ~~a percentage of the fertiliser~~ **%** by mass
 - where those nutrients are totally soluble in water, only as the content soluble in water;
 - where the soluble content of those nutrients is at least a quarter of the total content of those nutrients, the total content and the content soluble in water; and
 - in other cases, as the total content;
- (c) Where the declared micronutrient(s) are chelated by chelating agent(s), the following qualifier after the name and the chemical identifier of the micronutrient:
 - ‘chelated by...’ name of the chelating agent or its abbreviation, and the amount of chelated micronutrient as ~~a percentage of the CE marked EU fertilising product~~ **%** by mass;

(d) Where the ~~CE~~ marked EU fertilising product contains micronutrient(s) complexed by complexing agent(s) **the following qualifier after the name and the chemical identifier of the micronutrient:**

- ~~the following qualifier after the name and the chemical identifier of the micronutrient:~~ ‘complexed by ...’ **name of the complexing agent or its abbreviation**, and the amount of complexed micronutrient as a percentage of the ~~CE~~ marked EU fertilising product % by mass; and
- ~~the name of the complexing agent or its abbreviation.~~

(e) **In case micronutrients are intentionally added present:** The following statement: ‘To be used only where there is a recognised need. Do not exceed the ~~appropriate~~ **application** rate’.

PFC 1(C)(I)(b): Liquid inorganic macronutrient fertiliser

1. The label shall indicate whether the fertiliser is in suspension or in solution, ~~where~~
 - ~~a suspension means a two-phase dispersion in which solid particles are maintained in suspension in the liquid phase, and~~
 - ~~a solution means a liquid that is free of solid particles.~~
2. The nutrient content **may** ~~shall~~ be indicated as a percentage by **mass or** volume of the ~~CE~~ marked EU fertilising product.

3. Where one or more of the micronutrients boron (B), cobalt (Co), ~~copper (Cu)~~, iron (Fe), manganese (Mn), **and** molybdenum (Mo) ~~and zinc (Zn)~~, are present in the minimum content indicated below as a ~~percentage~~ **%** by mass, they

- shall be declared if they are intentionally added to the ~~CE~~-marked **EU** fertilising product, and
- may be declared in other cases:

Micronutrient	<u>Content of micronutrient</u> Percentage (<u>%</u> by mass)
Boron (B)	0,01
Cobalt (Co)	0,002
Copper (Cu)	0,002
Iron (Fe)	0,02
Manganese (Mn)	0,01
Molybdenum (Mo)	0,001
Zinc (<u>Zn</u>)	0,002

3a. Where one or both of the micronutrients copper (Cu) and zinc (Zn), are present, without being intentionally added, by at least 0,002 % by mass, they may be declared.

3b. Where copper (Cu) or zinc (Zn) is intentionally added to the liquid inorganic macronutrient fertiliser the total content of copper (Cu) or zinc (Zn) shall be declared.

3c. Micronutrients referred to in points 3, 3a and 3b They shall be declared after the information on macronutrients. The following information elements shall be present:

- (a) indication of the names and chemical symbols of the declared micronutrients, listed in the following order: boron (B), cobalt (Co), copper (Cu), iron (Fe), manganese (Mn), molybdenum (Mo) and zinc (Zn), followed by the name(s) of their counter-ion(s);
- (b) The total micronutrient content expressed as ~~a percentage of the fertiliser~~ **%** by **mass or volume**
 - where those nutrients are totally soluble in water, only as the content soluble in water;
 - where the soluble content of those nutrients is at least a quarter of the total content of those nutrients, the total content and the content soluble in water; and
 - in other cases, as the total content;

- (c) Where the declared micronutrient(s) are chelated by chelating agent(s), the following qualifier after the name and the chemical identifier of the micronutrient:
- ‘chelated by...’ name of the chelating agent or its abbreviation, and the amount of chelated micronutrient as a ~~percentage of the CE marked EU fertilising product~~ % by mass;
- (d) Where the ~~CE marked EU~~ fertilising product contains micronutrient(s) complexed by complexing agent(s) **the following qualifier after the name and the chemical identifier of the micronutrient:**
- ~~the following qualifier after the name and the chemical identifier of the micronutrient:~~ ‘complexed by ...’ **name of the complexing agent or its abbreviation**, and the amount of complexed micronutrient as % a ~~percentage of the CE marked EU fertilising product~~ by mass; and
 - ~~the name of the complexing agent or its abbreviation.~~
- (e) **In case micronutrients are intentionally added present** ~~present~~ The following statement: ‘To be used only where there is a recognised need. Do not exceed the appropriate **application** rate’.

PFC 1(C)(II): Inorganic micronutrient fertiliser

1. The declared micronutrients in the ~~CE-marked~~ EU fertilising product shall be listed by their names and chemical symbols in the following order: boron (B), cobalt (Co), copper (Cu), iron (Fe), manganese (Mn), molybdenum (Mo) and zinc (Zn), followed by the name(s) of their counter-ion(s),
2. Where the declared micronutrient(s) are chelated by chelating agent(s), and each chelating agent can be identified and quantified and chelates at least 1% water-soluble micronutrient, the following qualifier shall be added after the name and the chemical identifier of the micronutrient:
 - ‘chelated by...’ name of the chelating agent or its abbreviation, and the amount of chelated micronutrient as a percentage of the ~~CE-marked~~ EU fertilising product % by mass.
3. Where the declared micronutrient(s) are complexed by complexing agent(s), the following qualifier shall be added after the name and the chemical identifier of the micronutrient:
 - ‘complexed by ...’ **name of the complexing agent or its abbreviation**, and the amount of complexed micronutrient as a percentage of the ~~CE-marked~~ EU fertilising product % by mass, ~~and~~
 - ~~the name of the complexing agent or its abbreviation.~~
4. The following statement shall appear: ‘To be used only where there is a recognised need. Do not exceed the appropriate **application** rate’.

PFC 1(C)(II)(a): Straight inorganic micronutrient fertiliser

1. The label shall indicate the relevant typology, as referred to in the table under PFC 1(C)(II)(a) in Part II of Annex I.
2. The total micronutrient content shall be expressed as ~~a percentage of the fertiliser~~ % by mass
 - where the micronutrient is totally soluble in water, only as the content soluble in water;
 - where the soluble content of the micronutrient is at least a quarter of the total content of that nutrient, the total content and the content soluble in water; and
 - in other cases, as the total content.

PFC 1(C)(II)(b): Compound inorganic micronutrient fertiliser

1. Micronutrients can be declared only if they are present in the fertiliser in the following quantities **as % by mass**:

Micronutrient	<u>Content of micronutrient (% by mass)</u>	
	Non-chelated, non-complexed	Chelated or complexed
Boron (B)	0,2	n.a.
Cobalt (Co)	0,02	0,02
Copper (Cu)	0,5	0,1
Iron (Fe)	2	0,3
Manganese (Mn)	0,5	0,1
Molybdenum (Mo)	0,02	n.a.
Zinc (Zn)	0,5	0,1

2. If the fertiliser is in suspension or in solution, the label shall indicate "in suspension" or "in solution", as relevant.
3. The total micronutrient content shall be expressed as a ~~percentage of the fertiliser~~ **% by mass**
- where the micronutrients are totally soluble in water, only as the content soluble in water;
 - where the soluble content of the micronutrients is at least half of the total content of those nutrients, the total content and the content soluble in water; and
 - in other cases, as the total content.

PFC 2: LIMING MATERIAL

The following parameters shall be declared in the following order:

- Neutralising value;**
- Granulometry, expressed as % by mass passing through a determined sieve;**
- Total CaO, expressed as-% by mass;**
- Total MgO, expressed as % by mass;**
- Reactivity and method of determination of reactivity, except for oxide and hydroxide limes.**

PFC 3: SOIL IMPROVER

The following parameters shall be declared in the following order,

- ~~and expressed as a percentage of the CE marked EU fertilising product %~~ by mass:
 - Dry matter **content**;
 - ~~Organic carbon (C_{org}) content~~;
 - Total nitrogen (N) content; **if above 0,5 % by mass,**
 - Total phosphorus pentoxide (P_2O_5) content; **if above 0,5 % by mass,**
 - Total potassium oxide (K_2O) content; **if above 0,5 % by mass**
- ~~Total copper (Cu) and zinc (Zn) content, if above 200 and 600 mg/kg dry matter respectively;~~
and

PFC 3 (A) Organic soil improver

The following parameters shall be declared:

- — pH_i;
- **electrical conductivity, given as mS/m.**
- **organic carbon (C_{org}) content, expressed as % by mass**
- **minimum amount of organic nitrogen (N_{org}), expressed as % by mass, followed by a description of the origin of the organic matter used**
- **the ratio of organic carbon to total nitrogen (C_{org}/N)**

PFC 4: GROWING MEDIUM

The parameters shall be declared in the following order:

- Electrical conductivity **given as mS/m**, except for mineral wool;
- pH;
- Quantity
 - For mineral wool, expressed as number of pieces and the three dimensions length, height, and width,
 - For other pre-shaped growing media, expressed as size in at least two dimensions, and
 - For other growing media, expressed as total volume;
 - ———Except for pre-shaped growing media, quantity expressed as volume of materials with a particle size greater than 60 mm;
- ~~Total~~ **Nitrogen (N) extractable by CaCl₂/DTPA (calcium chloride/diethylenetriaminepentaacetic acid; 'CAT-soluble'), if above 150 mg/l;**
- ~~Total~~ **Pphosphorus pentoxide (P₂O₅) extractable by CaCl₂/DTPA (calcium chloride/diethylenetriaminepentaacetic acid; 'CAT-soluble'), if above 20 mg/l;** and
- ~~Total~~ **Ppotassium oxide (K₂O) extractable by CaCl₂/DTPA (calcium chloride/diethylenetriaminepentaacetic acid; 'CAT-soluble'), if above 150 mg/l.**
- **Production date.**

PFC 5: ~~AGRONOMIC ADDITIVE~~ INHIBITOR

Only the general labelling requirements apply to this PFC.

All ingredients shall be declared by product weight or volume in descending order of magnitude.

PFC 6: PLANT BIOSTIMULANT

The following information elements shall be present:

- (a) physical form;
- (b) ~~manufacturing~~ **production** and expiry date;
- (c) ~~storage conditions~~;
- (d) application method(s);
- (e) ~~dose~~ **application rate**, ~~timing (plant development stage)~~ and frequency of application;
- (f) effect claimed for each target plant; and
- (g) any relevant instructions related to the efficacy of the product, including soil management practices, chemical fertilisation, incompatibility with plant protection products, recommended spraying nozzles size, and sprayer pressure **and other anti drift measures**.

PFC 6(A): Microbial plant biostimulant

All intentionally added microorganisms shall be indicated. Where the microorganism has several strains, the intentionally added strains shall be indicated. Their concentration shall be expressed as the number of active units per volume or weight, or in any other manner that is relevant to the micro-organism, e.g. colony forming units per gram (cfu/g).

The label shall contain the following phrase: 'Micro-organisms may have the potential to provoke sensitising reactions'.

PFC 7: FERTILISING PRODUCT BLEND

All the labelling requirements applicable to all component ~~CE~~-marked EU fertilising products apply to the ~~CE~~-marked EU fertilising product blend, and shall be expressed in relation to the final ~~CE~~-marked EU fertilising product blend.

Where the fertilising product blend contains one or more plant biostimulants belonging to PFC6, the concentration of each plant biostimulant in the blend shall be indicated in g/kg or g/l at 20°C.

PART 3

TOLERANCE RULES

1. The declared nutrient content or physico-chemical characteristics of a ~~CE marked~~ **EU** fertilising product may deviate from the actual value only in accordance with the tolerances established in this ~~Pp~~part for the relevant product function category. The tolerances are intended to allow for deviations in manufacture, **in the distribution chain, during** sampling and analysis.
2. The tolerances allowed in respect of the declared parameters indicated in this Part are negative and positive values ~~in percentage by mass~~.
3. ~~The manufacturer, importer or distributor shall not take systematic advantage of the tolerances.~~
4. By derogation from paragraph 1, the actual content in a ~~CE marked~~ **EU** fertilising product of a component for which a minimum or a maximum content is specified in Annex I or Annex II may never be lower than the minimum content or exceed the maximum content.

PFC 1: FERTILISER

The following tolerance rules apply to fertilisers containing nitrification, ~~or~~ urease or denitrification inhibitors, as specified in component material category (CMC) 1 in Annex II:

<u>Inhibitors</u>	<u>Permissible tolerance for the declared content of inhibitors</u>
<u>Concentration below or equal to 2%</u>	<u>± 20 % of the declared value</u>
<u>Concentration of more than 2%</u>	<u>± 0,3 percentage points in absolute terms</u>

PFC 1(A): Organic fertiliser

	Permissible tolerance for the declared nutrient content and other declared parameter
Organic carbon (C _{org})	± 20 % relative deviation of the declared value up to a maximum of 2,0 percentage point in absolute terms
Dry matter content	± 5,0 percentage point in absolute terms
Total nitrogen (N)	± 50 % relative deviation of the declared value up to a maximum of 1,0 percentage point in absolute terms
Organic nitrogen (N _{org})	± 50 % relative deviation of the declared value up to a maximum of 1,0 percentage point in absolute terms
Total phosphorus pentoxide (P ₂ O ₅)	± 50 % relative deviation of the declared value up to a maximum of 1,0 percentage point in absolute terms
Total potassium oxide (K ₂ O)	± 50 % relative deviation of the declared value up to a maximum of 1,0 percentage point in absolute terms
Total and water-soluble magnesium oxide, calcium oxide, sulphur trioxide or sodium oxide	± 25% of the declared content of those nutrients up to a maximum of 1,5 percentage points in absolute terms.
Total copper (Cu)	± 50 % relative deviation of the declared value up to a maximum of 2,5 percentage points in absolute terms
Total zinc (Zn)	± 50 % relative deviation of the declared value up to a maximum of 2,0 percentage points in absolute terms
<u>Carbon (C_{org})/Nitrogen (N)</u>	<u>± 20% relative deviation of the declared value up to a maximum of 2,0 percentage points in absolute terms</u>
Quantity	- ± 1,5 5 % relative deviation of the declared value

PFC 1(B): Organo-mineral fertiliser

	<u>Permissible tolerance for the declared macronutrient content and other declared parameter</u>
<u>Organic carbon (C_{org})</u>	<u>± 20 % relative deviation of the declared value up to a maximum of 2,0 percentage point in absolute terms</u>
<u>Dry matter content</u>	<u>± 5,0 percentage point in absolute terms</u>
<u>Total Declared forms of inorganic nitrogen (N)</u>	<u>± 25 % relative deviation of the declared value up to a maximum of 2,0 percentage point in absolute terms</u>
<u>Organic nitrogen (N_{org})</u>	<u>± 50 % relative deviation of the declared value up to a maximum of 1,0 percentage point in absolute terms</u>
<u>Total Declared forms of phosphorus pentoxide (P₂O₅)</u>	<u>± 25 % relative deviation of the declared value up to a maximum of 1,5 2 percentage point in absolute terms</u>
<u>Total Declared forms of potassium oxide (K₂O)</u>	<u>± 25 % relative deviation of the declared value up to a maximum of 1,5 2percentage point in absolute terms</u>
<u>Total and water-soluble magnesium oxide (MgO), calcium oxide (CaO), sulphur trioxide (SO₃)</u>	<u>± 25% of the declared content of those nutrients up to a maximum of 1 4,5 percentage points in absolute terms.</u>
<u>Total and water-soluble sodium oxide (Na₂O)</u>	<u>± 25% of the declared content up to a maximum of 0,9 percentage points in absolute terms</u>
<u>Quantity</u>	<u>±1,5 5 % relative deviation of the declared value</u>

Permissible tolerance for the declared content of forms of inorganic macronutrient						
N	P ₂ O ₅	K ₂ O	MgO	CaO	SO ₃	Na ₂ O
± 25% of the declared content of the nutrient forms present up to a maximum of 2 percentage point in absolute terms			± 25% of the declared content of those nutrients up to a maximum of 1,5 percentage points in absolute terms.		± 25% of the declared content up to a maximum of 0,9 percentage points in absolute terms	

Micro-nutrient fertilisers	Permissible tolerance for the declared content of forms of micronutrient
Concentration below or equal to 2%	± 20 % of the declared value
Concentration of more than 2 % between 2,1% and below or equal to 10%	± 0,3 percentage points ± 20 % of the declared value and 1 percentage point in absolute terms
Concentration of more than 10%	± 1,0 percentage points in absolute terms

Organic carbon: ± 20 % relative deviation of the declared value up to a maximum of 2,0 percentage point in absolute terms

Organic nitrogen: ± 50 % relative deviation of the declared value up to a maximum of 1,0 percentage point in absolute terms

Total copper (Cu) — ± 50 % relative deviation of the declared value up to a maximum of 2,5 percentage points in absolute terms

Total zinc (Zn) — ± 50 % relative deviation of the declared value up to a maximum of 2,0 percentage points in absolute terms

Dry matter content: ± 5,0 percentage point in absolute terms

Quantity: ± 5% relative deviation of the declared value

PFC 1(C): Inorganic fertiliser

PFC 1(C)(I): Inorganic macronutrient fertiliser

	<u>Permissible tolerance for the declared macronutrient content and other declared parameter</u>
<u>Total Declared forms of nitrogen (N)</u>	<u>± 25 20 % relative deviation of the declared value up to a maximum of 1,5 2,0 percentage point in absolute terms</u>
<u>Total Declared forms of phosphorus pentoxide (P₂O₅)</u>	<u>± 25 20 % relative deviation of the declared value up to a maximum of 1,5 2,0 percentage point in absolute terms</u>
<u>Total Declared forms of potassium oxide (K₂O)</u>	<u>± 25 20% relative deviation of the declared value up to a maximum of 1,5 2,0 percentage point in absolute terms</u>
<u>Declared forms of N, P₂O₅ or K₂O in binary fertilisers</u>	<u>± 1,5 % points in absolute terms</u>
<u>Declared forms of N, P₂O₅ or K₂O in tertiary fertilisers</u>	<u>± 1,9 % points in absolute terms</u>
<u>Total and water-soluble magnesium oxide (MgO), calcium oxide (CaO), sulphur trioxide (SO₃)</u>	<u>± 25% of the declared content of those nutrients up to a maximum of 1 1,5 percentage points in absolute terms.</u>
<u>Total and water soluble sodium oxide (Na₂O)</u>	<u>± 25% of the declared content up to a maximum of 0,9 percentage points in absolute terms</u>
<u>Granulometry</u>	<u>± 10 % relative deviation applicable to of the declared percentage of material passing a specific sieve</u>
<u>Quantity</u>	<u>± 1 5 % relative deviation of the declared value</u>

Permissible tolerance for the declared content of forms of macronutrient						
N	P ₂ O ₅	K ₂ O	MgO	CaO	SO ₃	Na ₂ O
± 25% of the declared content of the nutrient forms present up to a maximum of 2 percentage point in absolute terms			± 25% of the declared content of those nutrients up to a maximum of 1,5 percentage points in absolute terms.		± 25% of the declared content up to a maximum of 0,9 percentage points in absolute terms	

Granulometry: ± 10 % relative deviation applicable to the declared percentage of material passing a specific sieve

Quantity: ± 5 % relative deviation of the declared value

PFC 1(C)(II): Inorganic micronutrient fertiliser

Micro-nutrient fertilisers	Permissible tolerance for the declared content of forms of micro-nutrient
Concentration below or equal to 2%	± 20 % of the declared value
Concentration of more than 2 % between 2,1% and below or equal to 10%	± 0,3 percentage points ± 20 % of the declared value and 1 percentage point in absolute terms
Concentration of more than 10%	± 1,0 percentage points in absolute terms

Quantity: ± 5 % relative deviation of the declared value

PFC 2: LIMING MATERIAL

	Permissible tolerances for the declared parameter
Neutralising value	± 3
Granulometry	± 10 % relative deviation applicable to of the declared percentage of material passing a specific sieve.
Total calcium oxide	± 3 percentage points in absolute terms
Total magnesium oxide Concentration below 8% Concentration between 8 to 16% Concentration above or equal to 16%	± 1,0 percentage points in absolute terms ± 2,0 percentage points in absolute terms ± 3,0 percentage points in absolute terms
Reactivity <u>ies (hydrochloric acid test and incubation test)</u>	± 45 percentage points in absolute terms
Quantity	- ± 15 % relative deviation applicable to of the declared value

PFC 3: SOIL IMPROVER

Forms of the declared nutrient and other declared quality criteria	Permissible tolerances for the declared parameter
pH	$\pm 0,7$ at the time of manufacture $\pm 1,0$ % <u>relative deviation of the declared value</u> at any time in the distribution chain
Organic carbon (C_{org})	$\pm 10\%$ relative deviation of the declared value up to a maximum of 1,0 percentage points in absolute terms
<u>Organic nitrogen (N_{org})</u>	<u>± 50 % relative deviation of the declared value up to a maximum of 1,0 percentage point in absolute terms</u>
Total nitrogen (N)	$\pm 20\%$ relative deviation up to a maximum of 1,0 percentage point in absolute terms
Total phosphorus pentoxide (P_2O_5)	$\pm 20\%$ relative deviation up to a maximum of 1,0 percentage point in absolute terms
Total potassium oxide (K_2O)	$\pm 20\%$ relative deviation up to a maximum of 1,0 percentage point in absolute terms
Dry matter <u>content</u>	$\pm 10\%$ relative deviation of the declared value
Quantity	± 5 % relative deviation of the declared value at the time of manufacture -25% relative deviation of the declared value at any time in the distribution chain
Carbon (C_{org})_{org} / Nitrogen (N_{org})_{org}	$\pm 20\%$ relative deviation of the declared value up to a maximum of 2,0 percentage points in absolute terms
<u>Electrical conductivity</u>	<u>$\pm 50\%$ relative deviation at the time of manufacture</u> <u>$\pm 75\%$ relative deviation of the declared value at any time in the distribution chain</u>
Granulometry	± 10 % relative deviation applicable to <u>of</u> the declared percentage of material passing a specific sieve.

PFC 4: GROWING MEDIUM

Forms for the declared nutrient and other declared quality criteria	Permissible tolerances for the declared parameter
Electrical <u>al</u> conductivity	± 50% relative deviation at the time of manufacture ± 75% relative deviation of the declared value at any time in the distribution chain
pH	± 0,7 at the time of manufacture ± 1,0 of the declared value at any time in the distribution chain
Quantity by volume (litres or m ³)	± 1,5 5 % relative deviation at the time of manufacture ± 25% relative deviation of the declared value at any time in the distribution chain
Quantity (volume) determination of materials with particle size greater than 60 mm	± 5% relative deviation at the time of manufacture ± 25% relative deviation of the declared value at any time in the distribution chain
Quantity (volume) determination of pre-shaped <u>GM-growing medium</u>	± 5% relative deviation at the time of manufacture ± 25% relative deviation of the declared value at any time in the distribution chain
Water-soluble <u>N</u>itrogen (N) extractable by CaCl₂/DTPA (calcium chloride/ diethylenetriaminepentaacetic acid; 'CAT-soluble')	± 50% relative deviation at the time of manufacture ± 75% relative deviation of the declared value at any time in the distribution chain
Water-soluble <u>P</u>hosphorus pentoxide (P₂O₅) extractable by CaCl₂/DTPA (calcium chloride/ diethylenetriaminepentaacetic acid; 'CAT-soluble')	± 50% relative deviation at the time of manufacture ± 75% relative deviation of the declared value at any time in the distribution chain
Water-soluble <u>P</u>otassium oxide (K₂O) extractable by CaCl₂/DTPA (calcium chloride/ diethylenetriaminepentaacetic acid; 'CAT-soluble')	± 50% relative deviation at the time of manufacture ± 75% relative deviation of the declared value at any time in the distribution chain

PFC 5: INHIBITORS

<u>Inhibiting compound</u>	<u>Permissible tolerance for the declared content of inhibiting compound</u>
<u>Concentration below or equal to 2%</u>	<u>± 20 % of the declared value</u>
<u>Concentration of more than 2%</u>	<u>± 0,3 percentage points in absolute terms</u>

Quantity: ± 5 % relative deviation of the declared value

PFC 6 (A): MICROBIAL PLANT BIOSTIMULANT

The actual concentration(s) of microorganisms may deviate by no more than 15 % from the declared value(s).

PFC 7: FERTILISING PRODUCT BLEND

Where the fertilising product blend contains one or more plant biostimulants belonging to PFC6, the following tolerances shall apply for the declared concentration of each plant biostimulant:

<u>Declared content concentration in g/kg or g/l at 20°C</u>	<u>Permissible tolerance</u>
Up to 25	± 15% relative deviation for PFC 6 ± 15% relative deviation when plant biostimulants are blended with other CE marked <u>EU</u> fertilising products under PFC 7
More than 25 up to 100	± 10% relative deviation
More than 100 up to 250	± 6% relative deviation
More than 250 up to 500	± 5% relative deviation
More than 500	± 25g/kg or ± 25g/l

Conformity assessment procedures

PART 1

APPLICABILITY OF CONFORMITY ASSESSMENT PROCEDURES

This Part sets out the applicability of conformity assessment procedure modules, as specified in Part 2 of this Annex, to ~~CE marked~~ **EU** fertilising products depending on their Component Material Categories as specified in Annex II ('CMC'), and their Product Function Categories as specified in Annex I ('PFC').

1. APPLICABILITY OF INTERNAL PRODUCTION CONTROL (MODULE A)

1. Module A may be used for a ~~CE marked~~ **EU** fertilising product composed solely of one or more **of the following component materials:**

- (a) virgin material substances or mixtures as specified in CMC 1, **except a nitrification inhibitor, a urease inhibitor or a denitrification inhibitor,**
- (b) ~~energy~~ **fresh** crop digestates as specified in CMC 4,
- (c) food industry by-products as specified in CMC 6,
- (d) micro-organisms as specified in CMC 7,
- ~~(e) agronomic additives as specified in CMC 8, or~~
- (f) nutrient polymers as specified in CMC 9.

2. Module A may also be used for a fertilising product blend as specified in PFC 7.
3. By derogation from paragraphs 1 and 2, Module A must not be used for:
 - (a) a straight or compound solid inorganic macronutrient ammonium nitrate fertiliser of high nitrogen content, as specified in PFC 1(C)(I)(a)(i ii)(A), or a fertilising product blend **as specified in PFC 7 containing 28 % or more by mass of nitrogen (N) from an EU fertilising product belonging to PFC 1(C)(I)(a)(i-ii)(A)** ~~such a product,~~
 - (b) ~~an nitrification~~ inhibitor as specified in PFC 5(A)(I),
 - (c) ~~a urease inhibitor as specified in PFC 5(A)(II),~~ or
 - (d) a plant biostimulant as specified in PFC 6.

2. APPLICABILITY OF INTERNAL PRODUCTION CONTROL PLUS SUPERVISED PRODUCT TESTING (MODULE A1)

Module A1 shall be used for a straight or compound solid inorganic macronutrient ammonium nitrate fertiliser of high nitrogen content, as specified in PFC 1(C)(I)(a)(i ii)(A), and for a fertilising product blend as specified in PFC 7 containing **28 % or more by mass of nitrogen (N) from an EU fertilising product belonging to PFC 1(C)(I)(a)(i-ii)(A)** ~~such a product.~~

3. APPLICABILITY OF EU-TYPE EXAMINATION (MODULE B) ~~AND~~ FOLLOWED BY CONFORMITY TO TYPE BASED ON INTERNAL PRODUCTION CONTROL (MODULE C)

1. Module B ~~in combination with~~ followed by Module C may be used for a ~~CE~~-marked EU fertilising product composed solely of one or more of the following component materials:
 - (a) nitrification inhibitor, urease inhibitor or denitrification inhibitor as specified in CMC 1,
 - (aa) ~~non-processed or mechanically processed plants, plant parts or plant extracts as specified in CMC 2,~~
 - (b) other polymers than nutrient polymers as specified in CMC 10,
 - (c) certain products derived from animal by-products as specified in CMC 11, ~~or~~
 - (d) ~~CMCs~~ Component Material Categories referred to in eligible for Module A pursuant to paragraph 1 under Heading 1 ~~on applicability of that Module.~~
2. Module B ~~and~~ followed by Module C may also be used for:
 - (a) ~~an~~ nitrification inhibitor as specified in PFC 5(A)(I),
 - ~~(b) a urease inhibitor as specified in PFC 5(A)(II),~~
 - (c) a plant biostimulant as specified in PFC 6, and
 - (d) a fertilising product blend referred to in eligible for Module A pursuant to paragraph 2 under Heading 1 on applicability of that Module.
3. By derogation from paragraphs 1 and 2, Module B ~~and~~ followed by Module C must not be used for a straight or compound solid inorganic macronutrient ammonium nitrate fertiliser of high nitrogen content, as specified in PFC 1(C)(I)(a)(i-ii)(A), or a fertilising product blend as specified in PFC 7 containing 28 % or more by mass of nitrogen (N) from an EU fertilising product belonging to PFC 1(C)(I)(a)(i-ii)(A) such a product.

4. APPLICABILITY OF QUALITY ASSURANCE OF THE PRODUCTION PROCESS (MODULE D1)

1. Module D1 may be used for any ~~CE marked~~ EU fertilising product.
2. By derogation from paragraph 1, Module D1 must not be used for a straight or compound solid inorganic macronutrient ammonium nitrate fertiliser of high nitrogen content, as specified in PFC 1(C)(I)(a)(i ii)(A), or a fertilising product blend **as specified in PFC 7** containing **28 % or more by mass of nitrogen (N) from an EU fertilising product belonging to PFC 1(C)(I)(a)(i-ii)(A)** such a product.

PART 2

DESCRIPTION OF CONFORMITY ASSESSMENT PROCEDURES

MODULE A – INTERNAL PRODUCTION CONTROL

1. Description of the module

1.1. Internal production control is the conformity assessment procedure whereby the manufacturer fulfils the obligations laid down under Headings 2, 3 and 4 below, and ensures and declares on his or her sole responsibility that the ~~CE-marked~~ EU fertilising products concerned satisfy the requirements of this Regulation that apply to them.

2. Technical documentation

2.1 The manufacturer shall establish the technical documentation. The documentation shall make it possible to assess the ~~CE-marked~~ EU fertilising product's conformity ~~to~~ with the relevant requirements, and shall include an adequate analysis and assessment of the risk(s).

- 2.2 The technical documentation shall specify the applicable requirements and cover, as far as relevant for the assessment, the design, manufacture and **intended** use of the ~~CE~~-marked **EU** fertilising product. The technical documentation shall contain, **wherever applicable**, at least the following elements:
- (a) a general description of the ~~CE~~-marked **EU** fertilising product, **the PFC corresponding to the claimed function of the product and description of the intended use,**
 - (aa) a lists of component materials used, the CMCs to which they belong and information for their origin or manufacturing process,**
 - (ab) the EU declarations of conformity for the component EU fertilising products of the fertilising product blend,**
 - (ac) information about maximum quantity and source of total chromium Cr in a clear manner, if the actual concentration is above 200 mg/kg dry matter.**
 - ~~(b) conceptual design and manufacturing drawings and schemes,~~
 - (c) **drawings, schemes,** descriptions and explanations necessary for the understanding of those ~~drawings and schemes and the use~~ **the manufacturing process** of the ~~CE~~-marked **EU** fertilising product,
 - (ca) a specimen of the label or the relevant accompanying document containing the information required in accordance with Annex III,**

- (d) a list of the harmonised standards **referred to in Article 12, and** a list of common specifications **referred to in Article 13 and**/or other relevant technical specifications applied. In the event of partly applied harmonised standards, the technical documentation shall specify the parts which have been applied,

~~a list of the harmonised standards applied in full or in part the references of which have been published in the Official Journal of the European Union and, where those harmonised standards have not been applied, descriptions of the solutions adopted to meet the essential requirements of this Regulation, including a list of common specifications or other relevant technical specifications applied. In the event of partly applied harmonised standards, the technical documentation shall specify the parts which have been applied,~~

- (e) results of design calculations made, **including the calculations to demonstrate conformity with point 4 of Part II of Annex I**, examinations carried out, etc., and
- (f) test reports **and**

3. Manufacturing

- 3- The manufacturer shall take all measures necessary so that the manufacturing process and its monitoring ensure compliance of the manufactured ~~CE-marked~~ EU fertilising products with the technical documentation referred to under Heading 2 above and with the requirements of this Regulation that apply to them.

4. CE marking, and EU declaration of conformity

- 4.1. The manufacturer shall affix the CE marking to each individual packaging of the EU fertilising product that satisfies the applicable requirements of this Regulation, **or, where it is supplied without packaging, in a document accompanying the EU fertilising product.**
- 4.2. The manufacturer shall draw up a written EU declaration of conformity for each an ~~CE marked~~ EU fertilising product ~~lot~~ **or type** and keep it together with the technical documentation at the disposal of the national authorities for ~~10~~ **5** years after the ~~CE-marked~~ EU fertilising product has been placed on the market. The EU declaration of conformity shall identify the ~~CE-marked~~ EU fertilising product **or type** for which it has been drawn up.
- 4.3. A copy of the EU declaration of conformity shall ~~accompany every CE-marked~~ EU fertilising product **be made available to the relevant authorities upon request.**

5. Authorised representative

- 5- The manufacturer's obligations set out under Heading 4 above may be fulfilled by his or her authorised representative, on his or her behalf and under his or her responsibility, provided that they are specified in the mandate.

MODULE A1 –

INTERNAL PRODUCTION CONTROL PLUS SUPERVISED PRODUCT TESTING

1. Description of the module

‡ Internal production control plus supervised product testing is the conformity assessment procedure whereby the manufacturer fulfils the obligations laid down under Headings 2, 3, 4, and 5 below, and ensures and declares on his or her sole responsibility that the ~~CE-marked~~ EU fertilising products concerned satisfy the requirements of this Regulation that apply to them.

2. Technical documentation

2.1. The manufacturer shall establish the technical documentation. The documentation shall make it possible to assess the ~~CE-marked~~ EU fertilising product's conformity with the relevant requirements, and shall include an adequate analysis and assessment of the risk(s).

- 2.2. The technical documentation shall specify the applicable requirements and cover, as far as relevant for the assessment, the design, manufacture and **intended** use of the ~~CE~~-marked **EU** fertilising product. The technical documentation shall contain, wherever applicable, at least the following elements:
- (a) a general description of the ~~CE~~-marked **EU** fertilising product, **the PFC corresponding to the claimed function of the product and description of the intended use,**
 - (aa) a lists of component materials used, the CMCs to which they belong and information for their origin or manufacturing process,**
 - (ab) the EU declarations of conformity for the component EU fertilising products of the fertilising product blend,**
 - (ac) information about maximum quantity and source of total chromium Cr in a clear manner if the actual concentration is above 200 mg/kg dry matter.**
 - ~~(b) conceptual design and manufacturing drawings and schemes,~~
 - (c) **drawings, schemes,** descriptions and explanations necessary for the understanding of ~~those drawings and schemes and the use~~ **the manufacturing process** of the ~~CE~~-marked **EU** fertilising product,
 - (ca) a specimen of the label or the relevant accompanying document containing the information required in accordance with Annex III,**
 - (d) the names and addresses of the sites, and of the operators of the sites, at which the product and its principal components were manufactured,

- (e) a list of the harmonised standards **referred to in Article 12, and** a list of common specifications **referred to in Article 13 and**/or other relevant technical specifications applied. In the event of partly applied harmonised standards, the technical documentation shall specify the parts which have been applied

~~a list of the harmonised standards applied in full or in part the references of which have been published in the Official Journal of the European Union and, where those harmonised standards have not been applied, descriptions of the solutions adopted to meet the essential requirements of this Regulation, including a list of common specifications or other relevant technical specifications applied. In the event of partly applied harmonised standards, the technical documentation shall specify the parts which have been applied,~~

- (f) results of design calculations made, **including the calculations to demonstrate conformity with point 4 of Part II of Annex I,** examinations carried out, etc., and
- (g) test reports, **including the reports from product checks for oil retention and detonation resistance, referred to in point 4 and**

3. Manufacturing

3. The manufacturer shall take all measures necessary so that the manufacturing process and its monitoring ensure compliance of the manufactured ~~CE marked~~ **EU** fertilising products with the technical documentation referred to under Heading 2 above and with the requirements of this Regulation.

4. Product checks for oil retention and detonation resistance

4. The cycles and test referred to under Headings 4.1-4.3 below shall be carried out on a representative sample of the product ~~at least~~ every **3** months on behalf of the manufacturer, in order to verify conformity with

- (a) the oil retention requirement referred to in paragraph 4 under PFC 1(C)(I)(a)(i ii)(A) in Annex I to this Regulation, and
- (b) the detonation resistance requirement referred to in paragraph 5 under PFC 1(C)(I)(a)(i ii)(A) in Annex I to this Regulation.

The **cycles and** tests shall be carried out under the responsibility of a notified body chosen by the manufacturer.

4.1. Thermal cycles prior to a test for compliance with the oil retention requirement referred to in paragraph 4 under PFC 1(C)(I)(a)(i ii)(A) in Annex I

4.1.1. Principle and definition

4.1.1. In ~~an~~ **a closed** suitable laboratory flask, heat the sample from ambient temperature to 50 °C and maintain at this temperature for a period of two hours (phase at 50 °C). Thereupon cool the sample until a temperature of 25 °C is achieved and maintain at that temperature for two hours (phase at 25 °C). The combination of the successive phases at 50 °C and 25 °C forms one thermal cycle. After being subjected to two thermal cycles, the test sample is held at a temperature of (20 ± 3) °C for the determination of the oil retention value.

4.1.2. Apparatus

4.1.2. Normal laboratory apparatus, in particular:

- (a) water baths or ovens thermostated at (25 ± 1) °C and (50 ± 1) °C respectively,
- (b) Suitable laboratory flask with an individual capacity of 150 ml.

4.1.3. Procedure

4.1.3.1. Put each test sample of (70 ± 5) g into a suitable laboratory flask which is then closed.

4.1.3.2. After attaining the temperature of 50 °C and maintain that temperature for two hours, change the temperature of the flask to the 25 °C bath or oven and vice versa.

4.1.3.3. If using a water bath maintain the water of each bath at constant temperature and keep in motion by rapid stirring. Ensure the water level comes above the level of the sample. Protect the stopper from condensation by a foam rubber cap.

4.1a. Oil retention test referred to in paragraph 4 under PFC 1(C)(I)(a)(i ii)(A) in Annex I

4.1a.1. Description

The oil retention of a EU fertilising product shall be the quantity of oil retained by the EU fertilising product determined under the operating conditions specified and expressed as a percentage by mass.

The test shall be carried out on a representative sample of the CE marked EU fertilising product. Before being tested , the whole mass of the sample shall be thermally cycled two times in accordance with the provisions under heading 4.1. above.

The method is applicable to both prilled and granular fertilisers which do not contain oil soluble materials.

4.1a.2. Principle

Total immersion of the test sample in gas oil for a specified period, followed by the draining away of surplus oil under specified conditions. Measurement of the increase in mass of the test portion.

4.1a.3. Reagents

Gas oil with properties

- a) Viscosity max.: 5 mPas at 40 °C**
- b) Density: 0,8 g/ml to 0,85 g/ml at 20 °C**
- c) Sulphur content: ≤ 1,0% (m/m)**
- d) Ash: ≤ 0,1 % (m/m)**

4.1a.4. Apparatus

Ordinary laboratory apparatus, and:

- a) Balance, capable of weighing to the nearest 0,01 gram.**
- b) Beakers, of capacity 500 ml.**
- c) Funnel, of plastic materials, preferably with a cylindrical wall at the upper end, diameter approximately 200 mm.**
- d) Test sieve, aperture 0,5 mm, fitting into the funnel (4.2a.4.c)).**

Note: The size of the funnel and sieve is such as to ensure that only a few granules lie one above another and the oil is able to drain easily.

- e) Filter paper, rapid filtering grade, creped, soft, mass 150 g/m².**
- f) Absorbent tissue (laboratory grade).**

4.1a.5. Procedure

4.1a.5.1. Two individual determinations are carried out in quick succession on separate portions of the same test sample.

4.1a.5.2. Remove particles smaller than 0,5 mm using the test sieve (5.4). Weigh to the nearest 0,01 g approximately 50 g of the sample into the beaker (5.2). Add sufficient gas oil (section 4) to cover the prills completely and stir carefully to ensure that the surfaces of all the prills are fully wetted. Cover the beaker with a watch glass and leave to stand for one hour at (25 ± 2) °C.

4.1a.5.3. Filter the entire contents of the beaker through the funnel (5.3) containing the test sieve (5.4). Allow the portion retained by the sieve to remain there for one hour so that most of the excess oil can drain away.

4.1a.5.4. Lay two sheets of filter paper (5.5) (about 500 mm x 500 mm) on top of each other on a smooth surface; fold the four edges of both filter papers upwards to a width of about 40 mm to prevent the prills from rolling away. Place two layers of absorbent tissue (5.6) in the centre of the filter papers. Pour the entire contents of the sieve (5.4) over the absorbent tissues and spread the prills evenly with a soft, flat brush. After two minutes lift one side of the tissues to transfer the prills to the filter papers beneath and spread them evenly over these with the brush. Lay another sheet of filter paper, similarly with its edges turned upward, on the sample and roll the prills between the filter papers with circular movements while exerting a little pressure. Pause after every eight circular movements to lift the opposite corners of the filter papers and return to the centre the prills that have rolled to the periphery. Keep to the following procedure: make four complete circular movements, first clockwise and then anticlockwise. Then roll the prills back to the centre as described above. This procedure to be carried out three times (24 circular movements, corners lifted twice). Carefully insert a new sheet of filter paper between the bottom sheet and the one above it and allow the prills to roll onto the new sheet by lifting the edges of the upper sheet. Cover the prills with a new sheet of filter paper and repeat the same procedure as described above. Immediately after rolling, pour the prills into a tared dish and reweigh to the nearest 0,01 g to determine the mass of the quantity of gas oil retained.

4.1a.5.5. Repeating the rolling procedure and reweighing

If the quantity of gas oil retained in the portion is found to be greater than 2,00 g, place the portion on a fresh set of filter papers and repeat the rolling procedure, lifting the corners in accordance with section 6.4 (two times eight circular movements, lifting once). Then reweigh the portion.

4.1a.5.6. Two oil retention tests per sample are to be carried out.

4.1a.6. Test report

4.1a.6.1. Expression of the results

4.1a.6.1.1. Method of calculation and formula

The oil retention, from each determination (6.1) expressed as a percentage by mass of the sieved test portion, is given by the equation:

$$\text{Oil retention} = \frac{m_2 - m_1}{m_1} \times 100$$

where:

m₁ is the mass, in grams, of the sieved test portion (6.2),

m₂ is the mass, in grams, of the test portion according to section 6.4 or 6.5 respectively as the result of the last weighing.

4.1a.6.1.2. Take as the result the arithmetic mean of the two individual determinations.

4.1a.6.2. The test report shall form part of the technical documentation.

4.2. Thermal cycles prior to the detonation resistance test referred to in paragraph 5 under PFC 1(C)(I)(a)(i ii)(A) in Annex I

4.2.1. Principle and definition

4.2.1. In a tight box heat the sample from ambient temperature to 50 °C and maintain at this temperature for a period of one hour (phase at 50 °C). Thereupon cool the sample until a temperature of 25 °C is achieved and maintain at that temperature for one hour (phase at 25 °C). The combination of the successive phases at 50 °C and 25 °C forms one thermal cycle. After being subjected to the required number of thermal cycles, the test sample is held at a temperature of (20 ± 3) °C pending the execution of the detonability test.

4.2.2. Apparatus

Method 1

- (a) A water bath, thermostated in a temperature range of 20 °C to 51 °C with a minimum heating and cooling rate of 10 °C/h, or two water baths, one thermostated at a temperature of 20 °C, the other at 51 °C. The water in the bath(s) is continuously stirred; the volume of the bath shall be large enough to guarantee ample circulation of the water.

- (b) A stainless steel box, watertight all around and provided with a **temperature recording device** ~~thermocouple~~ in the centre. The outside width of the box is (45 ± 2) mm and the wall thickness is 1,5 mm (see Figure 1 as an example). The height and length of the box can be chosen to suit the dimensions of the water bath, e.g. length 600 mm, height 400 mm.

Method 2

(a) Suitable oven, thermostated in a temperature range of 20 °C to 51 °C with a minimum heating and cooling rate of 10 °C/h.

(b) Suitable airtight plastics boxes or bags provided with a suitable temperature recording device in the centre of the sample or a stainless steel box as described in point 4.2.2 method 1 point (b). Once filled, the outside thickness of the box or bag shall be maximum 45 mm

4.2.3. Procedure

~~4.2.3.~~ Place a quantity of fertilisers sufficient for the detonation test into the boxes or bags ~~box~~ and close them. Place the stainless steel boxes ~~box~~ in the water bath **(method 1) or the boxes or bags in the oven (method 2)**. Heat the water **or oven** to 51 °C and measure the temperature in the centre of the fertiliser. One hour after the temperature at the centre has reached 50 °C **start cooling** ~~cool~~ ~~the water~~. One hour after the temperature at the centre has reached 25 °C **start heating** ~~heat the water to start~~ **for** the second cycle. In the case of two water baths or ovens , transfer the boxes or bags to the other bath or oven after each heating/cooling period.

Figure 1

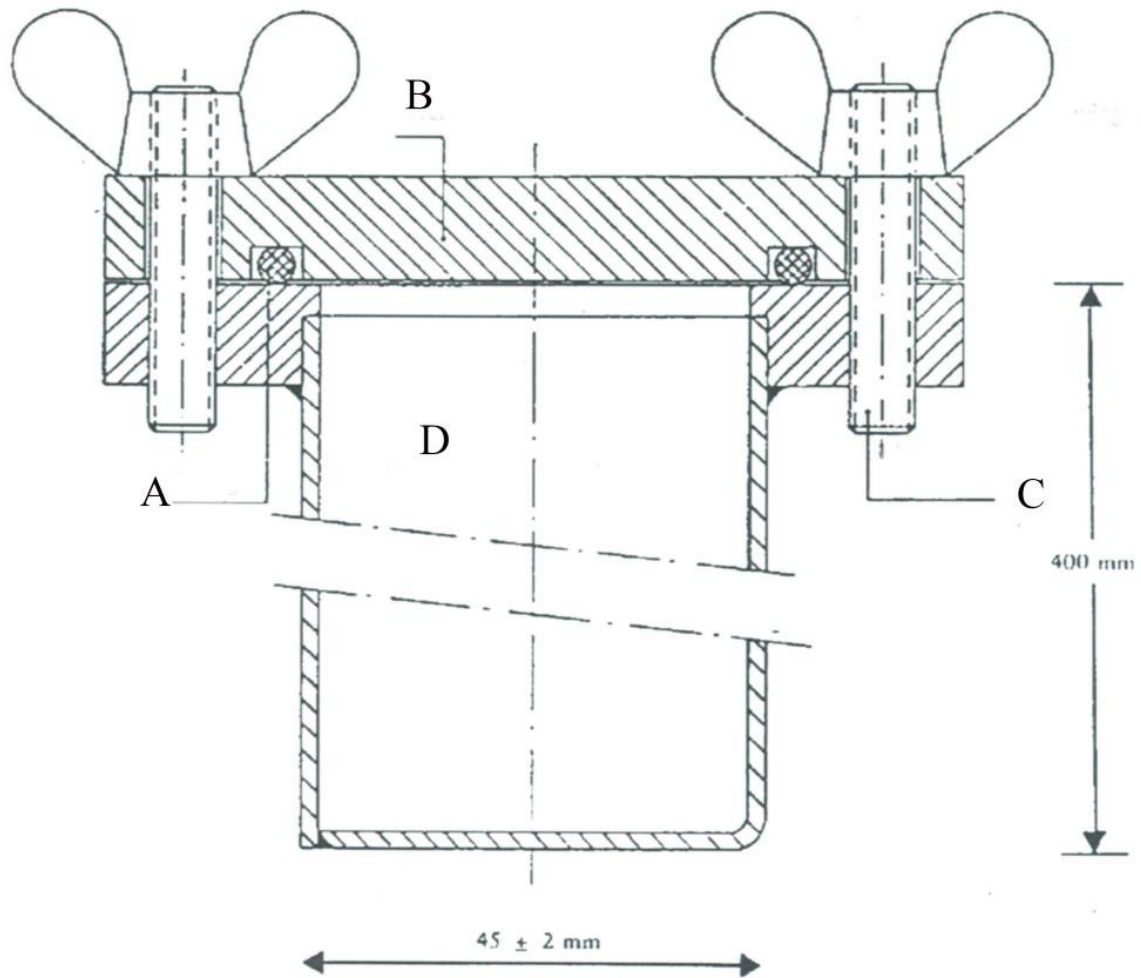

A: O-ring

B: Cover

C: Bolt

D: Box

4.3. Detonation resistance test referred to in paragraph 5 under PFC 1(C)(I)(a)(i ii)(A) in Annex I

4.3.1. Description

4.3.1.1 The test shall be carried out on a representative sample of the ~~CE marked~~ **EU** fertilising product. Before being tested for resistance to detonation, the whole mass of the sample is to be thermally cycled five times complying with the provisions under heading 4.2 above.

4.3.1.2. The ~~CE marked~~ **EU** fertilising product shall be subjected to the test of resistance to detonation in a horizontal steel tube under the following conditions (materials details found in 4.3.3)

- (a) seamless steel tube,
 - 1. Tube length: 1 000 mm at least,
 - 2. Nominal external diameter: 114 mm at least,
 - 3. Nominal wall thickness: 5 mm at least,
- (b) Booster: the type and mass of the booster chosen shall be such as to maximise the detonation pressure applied to the sample in order to determine its susceptibility to the transmission of detonation,
- (c) Temperature of the sample: 15 °C to 25 °C,
- (d) Witness lead cylinders for detecting detonation: 50 mm diameter and 100 mm ~~high~~ **height**,
- (e) placed at 150 mm intervals and supporting the tube horizontally.

NOTE : The test is to be carried out twice. The test is deemed conclusive if in both tests one or more of the supporting lead cylinders is crushed by less than 5 %.

4.3.2. Principle

4.3.2. The test sample is confined in a steel tube and subjected to detonation shock from an explosive booster charge. Propagation of the detonation is determined from the degree of crushing of lead cylinders on which the tube rests horizontally during the test.

4.3.3. Materials

(a) Plastic explosive containing 83 % to 86 % penthrite

- Density: 1 500 kg/m³ to 1 600 kg/m³
- Detonation velocity: 7 300 m/s to 7 700 m/s
- Mass: (500 ± 1) g .

Or any other plastic explosive with similar detonation characteristics

(b) Seven lengths of flexible detonating cord with non metallic sleeve

- Filling mass: 11 g/m to 13 g/m
- Length of each cord: (400 ± 2) mm.

- (c) Compressed pellet of secondary explosive, recessed to receive detonator
- Explosive: hexogen/wax 95/5 or similar secondary explosive, with or without added graphite.
 - Density: 1 500 kg/m³ to 1 600 kg/m³
 - Diameter: 19 mm to 21 mm
 - Height: 19 mm to 23 mm
 - Mass of the compressed pellet: maximum 10 g
 - Central recess to receive detonator: **maximal** diameter 7,0 to 7,3 mm, depth about 12 mm. **In case of detonators with large diameters, the diameter of the recess shall be slightly larger (e.g. 0.5 mm) than the diameter of the detonator.**
- (d) Seamless steel tube as specified in ISO 65 – 1981 – Heavy Series, with nominal dimensions DN 100 (4")
- Outside diameter: 113,1 mm to 115,0 mm
 - Wall thickness: 5,0 mm to 6,5 mm
 - Length: (1 005 ± 2) mm.

(e) Bottom plate

- Material: steel of good weldable quality
- Dimensions: 160 mm x 160 mm
- Thickness: 5 mm to 6 mm.

(f) Six lead cylinders

- Diameter: (50 ± 1) mm
- Height: 100 mm to 101 mm
- Materials: soft lead, at least 99,5 % purity.

(g) Steel block

- Length: at least 1 000 mm
- Width: at least 150 mm
- Height: at least 150 mm **(alternatively a stack of several beams can be used to achieve this height)**
- Mass: at least 300 kg if there is no firm base for the steel block.

- (h) Plastic or cardboard cylinder for booster charge
- Wall thickness: 1,5 mm to 2,5 mm
 - Diameter: 92 mm to 96 mm
 - Height: 64 mm to 67 mm.
- (i) Detonator (electric or non electric) with initiation force 8 to 10
- (j) Wooden **or plastic** disc
- Diameter: 92 mm to 96 mm. Diameter to be matched to the internal diameter of the plastic or cardboard cylinder (point (h) above)
 - Thickness: 20 mm.
- (k) Wooden **or plastic** rod of same dimensions as detonator (point (i) above)
- (l) ~~Dressmaking~~ **Split** pins (maximum length 20 mm)
- (m) Split pins (length about 20 mm)

4.3.4. Procedure

4.3.4.1. Preparation of booster charge for insertion into steel tube

4.3.4.1. Depending on the availability of equipment, the explosive can be initiated in the booster charge either

- by seven point simultaneous initiation as referred to under Heading 4.3.4.1.1. below, or
- by central initiation by a compressed pellet as referred to under Heading 4.3.4.1.2. below.

4.3.4.1.1. Seven point simultaneous initiation

4.3.4.1.1. The booster charge prepared for use is shown in Figure 2 below.

4.3.4.1.1.1. Drill holes in the wooden **or plastic** disc (point (j) under Heading 4.3.3. above) parallel to the axis of the disc through the centre and through six points symmetrically distributed around a concentric circle 55 mm in diameter. The diameter of the holes shall be 6 mm to 7 mm (see Section A B in Figure 2), depending on the diameter of the detonating cord used (point (b) under Heading 4.3.3. above).

4.3.4.1.1.2. Cut seven lengths of flexible detonating cord (point (b) under Heading 4.3.3. above) each 400 mm long, avoiding any loss of explosive at each end by making a clean cut and immediately sealing the end with adhesive. Push each of the seven lengths through each of the seven holes in the wooden **or plastic** disc (point (j) under Heading 4.3.3. above) until their ends project a few centimetres on the other side of the disc. Then insert a small dressmaking pin (point (l) under Heading 4.3.3. above) transversally into the textile sleeve of each length of cord 5 mm to 6 mm from the end and apply adhesive around the outside of the lengths of cord in a band 2 cm wide adjacent to the pin. Finally, pull the long piece of each cord to bring the pin into contact with the wooden **or plastic** disc.

4.3.4.1.1.3. Shape the plastic explosive (point (a) under Heading 4.3.3. above) to form a cylinder 92 mm to 96 mm in diameter, depending on the diameter of the cylinder (point (h) under Heading 4.3.3. above). Stand this cylinder upright on a level surface and insert the shaped explosive. Then insert the wooden **or plastic** disc³⁷ carrying the seven lengths of detonating cord into the top of the cylinder and press it down onto the explosive. Adjust the height of the cylinder (64 mm to 67 mm) so that its top edge does not extend beyond the level of the wood. Finally, fix the cylinder to the wooden **or plastic** disc for instance with staples or small nails, around its entire circumference.

4.3.4.1.1.4. Group the free ends of the seven lengths of detonating cord around the circumference of the wooden **or plastic** rod (point (k) under Heading 4.3.3. above) so that their ends are all level in a plane perpendicular to the rod. Secure them in a bundle around the rod by means of adhesive tape³⁸.

³⁷ The diameter of the disc must always correspond to the inside diameter of the cylinder.

³⁸ NB: When the six peripheral lengths of cord are taut after assembly, the central cord must remain slightly slack.

4.3.4.1.2. Central initiation by a compressed pellet

4.3.4.1.2. The booster charge prepared for use is shown in Figure 3.

4.3.4.1.2.1. Preparing a compressed pellet

4.3.4.1.2.1. Taking the necessary safety precautions, place **maximum** 10 g of a secondary explosive (point (c) under Heading 4.3.3. above) in a mould with an inside diameter of 19 mm to 21 mm and compress to the correct shape and density. (The ratio of diameter: height should be roughly 1:1). In the centre of the bottom of the mould there is a peg, 12 mm in height and 7,0 mm to 7,3 mm in diameter (depending on the diameter of the detonator used), which forms a cylindrical recess in the compressed cartridge for subsequent insertion of the detonator.

4.3.4.1.2.2. Preparing the booster charge

4.3.4.1.2.2. Place the explosive (point (a) under Heading 4.3.3. above) into the cylinder (point (h) under Heading 4.3.3. above) standing upright on a level surface, then press it down with a wooden **or plastic** die to give the explosive a cylindrical shape with a central recess. Insert the compressed pellet into this recess. Cover the cylindrically shaped explosive containing the compressed pellet with a wooden **or plastic** disc (point (j) under Heading 4.3.3. above) having a central hole 7,0 mm to 7,3 mm in diameter for insertion of a detonator. Fix the wooden **or plastic** disc and the cylinder together with a cross of adhesive tape. Ensure that the hole drilled in the disc and the recess in the compressed pellet are coaxial by inserting the wooden **or plastic** rod (point (k) under Heading 4.3.3. above).

4.3.4.2. Preparing steel tubes for the detonation tests

4.3.4.2. At one end of the steel tube (point (d) under Heading 4.3.3. above), drill two diametrically opposed holes 4 mm in diameter perpendicularly through the side wall at a distance of 4 mm from the edge. Butt weld the bottom plate (point (e) under Heading 4.3.3. above) to the opposite end of the tube, completely filling the right angle between the bottom plate and the wall of the tube with weld metal around the entire circumference of the tube.

4.3.4.3. Filling and charging the steel tube

4.3.4.3. See Figures 2 and 3.

4.3.4.3.1. The test sample, the steel tube and the booster charge shall be conditioned to temperatures of (20 ± 5) °C. About 20 kg of the test sample should be available for two detonation tests.

4.3.4.3.2.1 Place the tube upright with its square bottom plate resting on a firm, flat surface, preferably concrete. Fill the tube to about one third of its height with the test sample and drop it 10 cm vertically onto the flat surface five times to compact the prills or granules as densely as possible in the tube. To accelerate compaction, vibrate the tube by striking the side wall with a 750 g to 1 000 g hammer between drops for a total of 10 times.

4.3.4.3.2.2. Repeat this charging method with another portion of the test sample. Finally, a further addition shall be made such that, after compaction by raising and dropping the tube 10 times and a total of 20 intermittent hammer blows, the charge fills the tube to a distance of 70 mm from its orifice.

4.3.4.3.2.3 The filling height of the sample shall be adjusted in the steel tube so that the booster charge (referred to above under Heading 4.3.4.1.1. or 4.3.4.1.2.) to be inserted later will be in close contact with the sample over its entire surface.

4.3.4.3.3. Insert the booster charge into the tube so that it is in contact with the sample; the top surface of the wooden **or plastic** disc shall be 6 mm below the end of the tube. Ensure essential close contact between explosive and test sample by **taking out the booster charge and** adding or removing small quantities of sample. As shown in Figures 2 and 3, split pins should be inserted through the holes near the open end of the tube and their legs opened flat against the tube.

4.3.4.4. Positioning of the steel tube and lead cylinders (see figure 4)

4.3.4.4.1. Number the bases of the lead cylinders (point (f) under Heading 4.3.3. above) 1, **2, 3, 4, 5 and 6**. Make six marks 150 mm apart along a line on a steel block (4.3.7) lying on a horizontal base, with each mark at least 75 mm from any edge of the block. Place a lead cylinder upright on each of these marks, with the base of each cylinder centred on its mark (**see figure 4**).

4.3.4.4.2. Lay the steel tube prepared according to 4.3.4.3 horizontally on the lead cylinders so that the axis of the tube is parallel to the centre line of the lead cylinders and the welded end of the tube extends 50 mm beyond lead cylinder No 6. To prevent the tube from rolling, insert small wooden **or plastic** wedges between the tops of the lead cylinders and the tube wall (one on each side) or place a cross of wood between the tube and the steel block **or stack of beams**. (see figure 4)

Note: Make sure that the tube is in contact with all six lead cylinders; a slight curvature of the tube surface can be compensated for by rotating the tube about its longitudinal axis; if any of the lead cylinders is too tall, tap the cylinder in question carefully with a hammer until it is the required height.

4.3.4.5. Preparation for detonation

4.3.4.5.1. Set up the apparatus as described under Heading 4.3.4.4. in a bunker or suitably prepared underground site **or suitable location**. Ensure that the temperature of the steel tube is kept at (20 ± 5) °C before detonation.

Note: Detonation can cause steel fragments to be projected with high kinetic energy, therefore, firing shall be carried out at a suitable distance from dwellings or thoroughfares.

4.3.4.5.2. If the booster charge with seven point initiation is used, ensure that the detonation cords are stretched out as described in the footnote to paragraph 4.3.4.1.1.4 above and arranged as horizontally as possible.

4.3.4.5.3. Finally, remove the wooden **or plastic** rod and replace with the detonator. Do not carry out firing until the danger zone has been evacuated and the test personnel have taken cover.

4.3.4.5.4. Detonate the explosive.

4.3.4.6.1 Allow sufficient time for the fumes (gaseous and sometimes toxic decomposition products such as nitrous gases) to disperse, then collect the lead cylinders and measure their heights with a Vernier caliper

4.3.4.6.2. Record for each of the marked lead cylinders, the degree of crushing expressed as a percentage of the original height of 100 mm. If the cylinders are crushed obliquely, record the highest and the lowest values and calculate the average.

4.3.4.7. **Detonation velocity measurement can also be performed.**

4.3.4.8. Two detonation tests per sample are to be carried out.

4.3.5. Test report

4.3.5. Values for the following parameters are to be given in the test report for each of the detonation tests:

- the values actually measures for the outside diameter of the steel tube and for the wall thickness,
- the Brinell hardness of the steel tube,
- the temperature of the tube and the sample shortly before firing,
- the packing density (kg/m^3) of the sample in the steel tube,
- the height of each lead cylinder after firing, specifying the corresponding cylinder number,
- method of initiation employed for the booster charge.

4.3.5.1. Evaluation of test results

4.3.5.1. If, in each firing, the crushing of at least one lead cylinder is less than 5 %, the test shall be considered conclusive and that the sample presented is resistant to detonation

4.3.5a. The test report shall form part of the technical documentation.

Figure 2

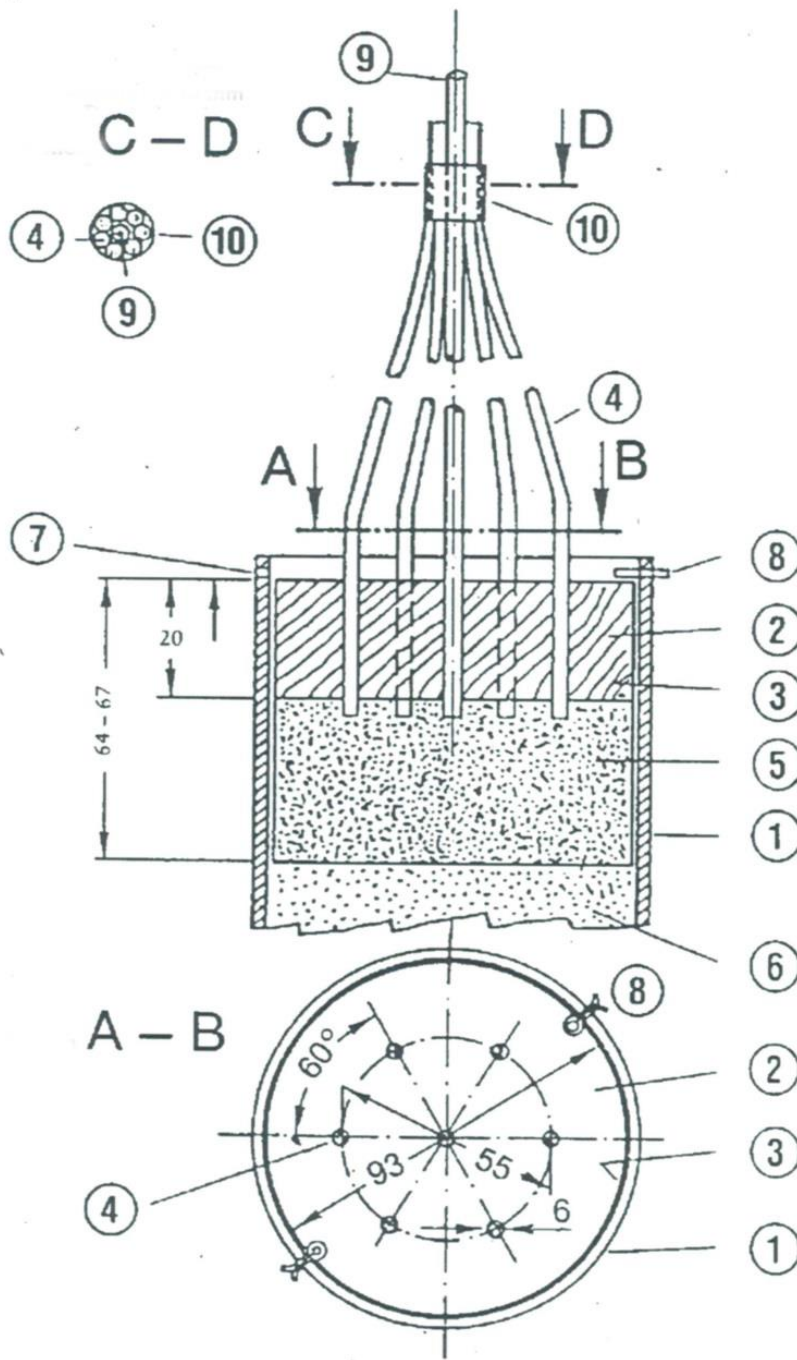

Booster charge with seven-point initiation

1: Steel tube

2: Wooden or plastic disk with seven holes

3: Plastic or cardboard cylinder

4: Detonating cords

5: Plastic explosive

6: Test sample

7: 4 mm hole drilled to receive split pin

8: Split pin

9: Wooden or plastic rod surrounded by 4

10: Adhesive tape for securing 4 around 9

Figure 3

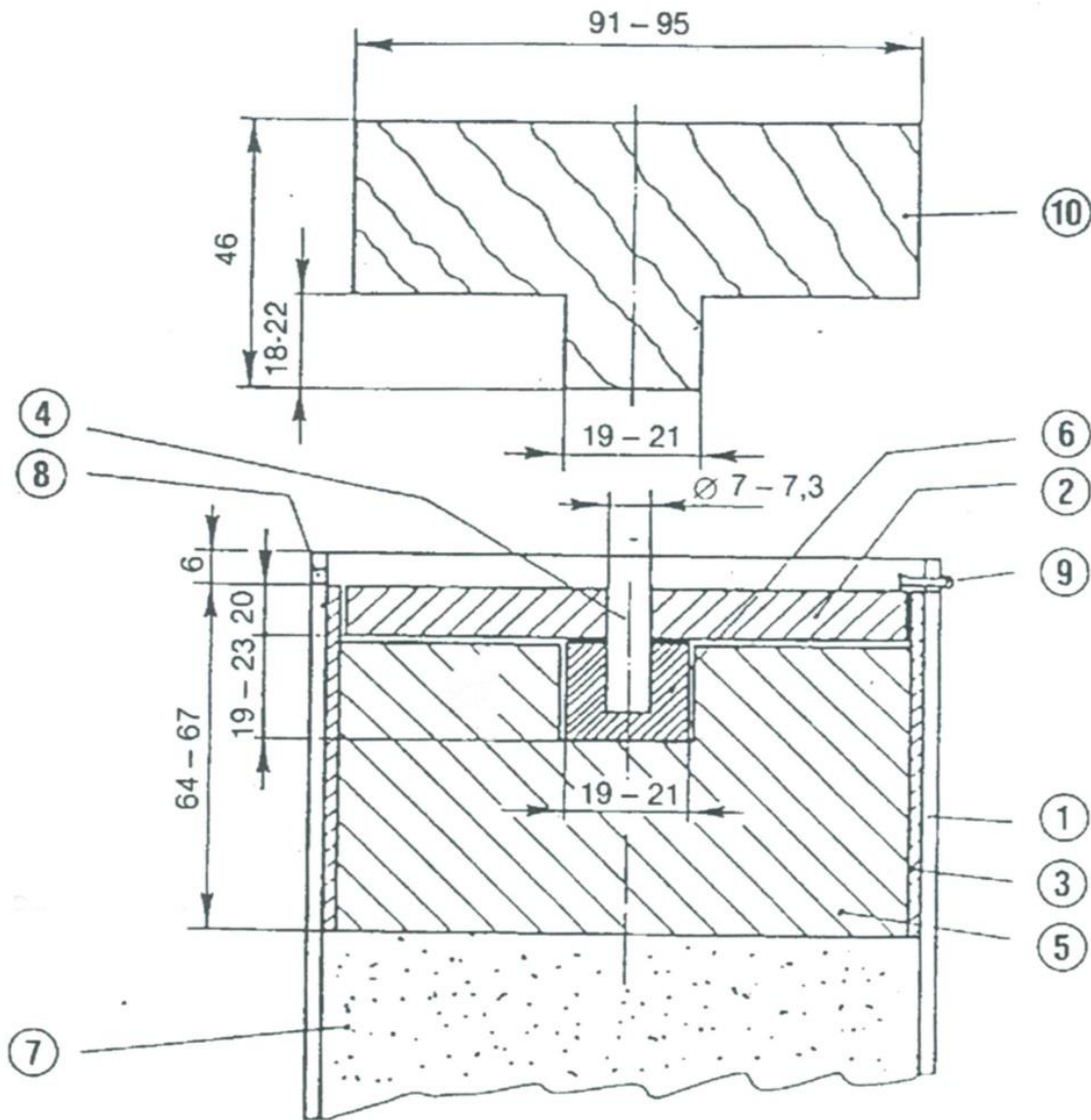

1: Steel tube

2: Wooden of plastic disk

3: Plastic or cardboard cylinder

4: Wooden of plastic rod

5: Plastic explosive

6: Compressed pellet

7: Test sample

8: 4 mm hole drilled to receive split pin

9: Split pin

10: Wooden or plastic die for 5

Figure 4

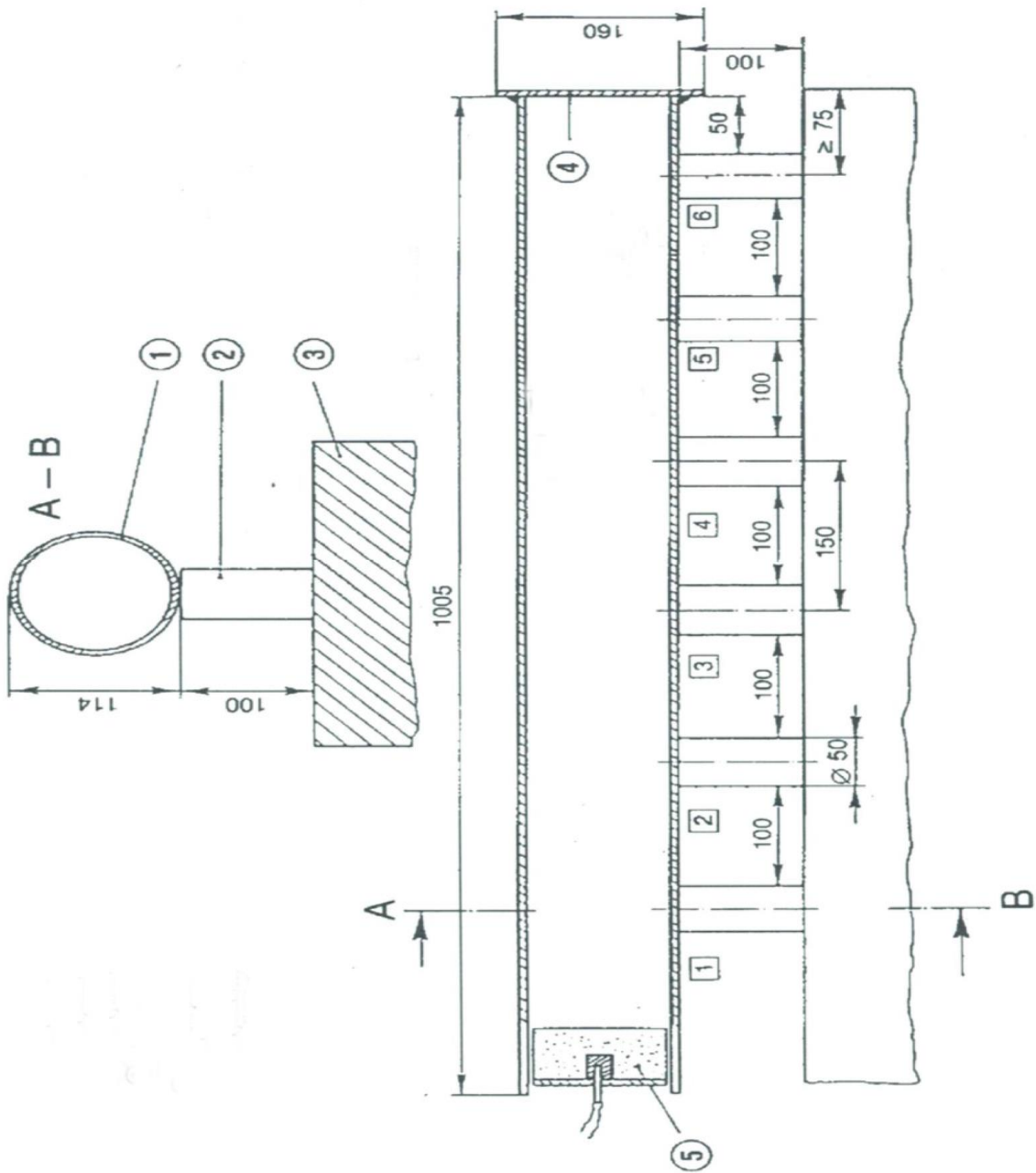

Numbers in circles:

1: Steel tube

2: Lead cylinders

3: Steel block or stack of beams

4: Bottom plate

5: Booster charge

Numbers in squares:

Lead cylinders 1 to 6

5. ~~Conformity~~ CE marking and EU declaration of conformity

5.1. The manufacturer shall affix the CE marking **and, under the responsibility of the notified body referred to in point 4, the latter's identification number** to each individual **packaging of the** fertilising product that satisfies the applicable requirements of this Regulation **or, where it is supplied without packaging, in a document accompanying the EU fertilising product.**

5.2. The manufacturer shall draw up a written EU declaration of conformity for ~~each~~ **an** ~~CE~~ ~~marked~~ EU fertilising product lot **type** and keep it together with the technical documentation at the disposal of the national authorities for ~~10~~ **5** years after the ~~CE-marked~~ EU fertilising product has been placed on the market. The EU declaration of conformity shall identify ~~such~~ **the** ~~CE-marked~~ EU fertilising product **type** for which it has been drawn up.

5.3. A copy of the EU declaration of conformity shall be made available to the relevant authorities upon request.

5a. Notified bodies' information and operational obligations

5a.1. Each notified body shall, without undue delay, inform its notifying authority and other bodies notified under this Regulation carrying out similar conformity assessment activities covering the same EU fertilising products of the following:

- (a) any case where the manufacturer has not complied with the 3-month period for performing the tests required under point 4;**
- (b) any test results which demonstrate non-conformity with the detonation resistance requirement referred to in paragraph 5 under PFC 1(C)(I)(a)(i-ii)(A) in Annex I.**

5a.2. In the case referred to in point 5a.1.(b) the notified body shall request the manufacturer:

- ~~**(a) to take the necessary measures in accordance with Article 6(8);**~~
- ~~**(b) to perform the relevant test every 2 months for a period of 1 year.**~~

6. Authorised representative

6. The manufacturer's obligations set out under **4.3.5a and** Heading 5 above may be fulfilled by his or her authorised representative, on his or her behalf and under his or her responsibility, provided that they are specified in the mandate.

MODULE B – EU-TYPE EXAMINATION

1. Description of the module

- 1.1** EU-type examination is the part of a conformity assessment procedure in which a notified body examines the technical design of a ~~CE-marked~~ **EU** fertilising product and verifies and attests that the technical design of the ~~CE-marked~~ **EU** fertilising product meets the requirements of this Regulation.
- 1.2.** Assessment of the adequacy of the technical design of the ~~CE-marked~~ **EU** fertilising product ~~may be~~ **is** carried out through examination of the technical documentation and supporting evidence ~~referred to in paragraph 2 below~~, plus examination of ~~specimens~~ **samples**, representative of the production envisaged, ~~of one or more critical components of the product (combination of production type and design type).~~

2a. Technical documentation

2.1 The manufacturer shall establish the technical documentation. The documentation shall make it possible to assess the EU fertilising product's conformity with the relevant requirements and shall include an adequate analysis and assessment of the risk(s). The technical documentation shall specify the applicable requirements and cover, as far as relevant for the assessment, the design, manufacture and intended use of the EU fertilising product. The technical documentation shall contain, wherever applicable, at least the following elements:

- (a) a general description of the EU fertilising product, the PFC corresponding to the claimed function of the product and description of the intended use,
- (b) a list of component materials used, the CMCs to which they belong and information for their origin or manufacturing process,
- (c) the EU declarations of conformity for the component EU fertilising products of the fertilising product blend,
- ~~(ca) information about maximum quantity and source of total chromium Cr in a clear manner, if the actual concentration is above 200 mg/kg dry matter;~~
- (d) drawings, schemes, descriptions and explanations necessary for the understanding of the manufacturing process of the EU fertilising product,

- (e) a specimen of the label or the relevant accompanying document containing the information required in accordance with Annex III,**
- (f) a list of the harmonised standards referred to in Article 12, common specifications referred to in Article 13 and/or other relevant technical specifications applied. In the event of partly applied harmonised standards, the technical documentation shall specify the parts which have been applied,**
- (g) results of ~~design~~ calculations made, including the calculations to demonstrate conformity with point 4 of Part II of Annex I, examinations carried out, etc., and**
- (h) test reports, and**
- (i) where the product contains or consists of products derived from animal by-products within the meaning of Regulation (EC) No 1069/2009, the commercial documents or health certificates required pursuant to that Regulation, and evidence that the derived products have reached the end point in the manufacturing chain within the meaning of that Regulation;**

3. Application for EU-type examination

- 3.1. The manufacturer shall lodge an application for EU-type examination with a single notified body of his or her choice.
- 3.2. The application shall include:
 - (a) the name and address of the manufacturer and, if the application is lodged by the authorised representative, his or her name and address as well,
 - (b) a written declaration that the same application has not been lodged with any other notified body,

(c) the technical documentation; ~~The technical documentation shall make it possible to assess the CE marked EU fertilising product's conformity with the applicable requirements of this Regulation and shall include an adequate analysis and assessment of the risk(s). The technical documentation shall specify the applicable requirements and cover, as far as relevant for the assessment, the design, manufacture and use of the CE marked EU fertilising product. The technical documentation shall contain, wherever applicable, at least the following elements:~~

- ~~• a general description of the CE marked EU fertilising product,~~
- ~~• conceptual design and manufacturing drawings and schemes~~
- ~~• descriptions and explanations necessary for the understanding of those drawings and schemes and the use of the CE marked EU fertilising product,~~
- ~~• a list of the harmonised standards applied in full or in part the references of which have been published in the Official Journal of the European Union and, where those harmonised standards have not been applied, descriptions of the solutions adopted to meet the essential requirements of this Regulation, including a list of common specifications or other relevant technical specifications applied. In the event of partly applied harmonised standards, the technical documentation shall specify the parts which have been applied,~~
- ~~• results of design calculations made, examinations carried out, etc.,~~
- ~~• test reports, and~~
- ~~• where the product contains or consists of **products derived from** animal by-products within the meaning of Regulation (EC) No 1069/2009, the commercial documents or health certificates required pursuant to that Regulation, and evidence that the animal by-**derived** products have reached the end point in the manufacturing chain within the meaning of that Regulation;~~

- (d) the ~~specimens~~ **samples** representative of the production envisaged. The notified body may request further ~~specimens~~ **samples** if needed for carrying out the test programme;
- (e) the supporting evidence for the adequacy of the technical design solution. This supporting evidence shall mention any documents that have been used, in particular where the relevant harmonised standards have not been applied in full. The supporting evidence shall include, where necessary, the results of tests carried out in accordance with other relevant technical specifications by the appropriate laboratory of the manufacturer, or by another testing laboratory on his or her behalf and under his or her responsibility.

4a. Assessment of the adequacy of the technical design

4.—The notified body shall:

(a) —~~For the CE marked~~ **EU** fertilising product:

- (1) examine the technical documentation and supporting evidence to assess the adequacy of the technical design of the ~~CE marked~~ **EU** fertilising product;

(b) ~~For the specimen(s):~~

- (2) verify that the ~~specimen-~~**sample** (s) have been manufactured in conformity with the technical documentation, and identify the elements which have been designed in accordance with the applicable provisions of the relevant harmonised standards ~~and/or technical~~ **or common** specifications, as well as the elements which have been designed in accordance with other relevant technical specifications;
- (3) carry out appropriate examinations and tests **on the** ~~specimen-~~**sample (s)**, or have them carried out, to check whether, where the manufacturer has chosen to apply the solutions in the relevant harmonised standards, ~~and/or technical~~ **or has applied common** specifications, these have been applied correctly;
- (4) carry out appropriate examinations and tests **on the** ~~specimen-~~**sample(s)**, or have them carried out, to check whether, where the solutions in the relevant harmonised standards ~~and/or technical~~ **common** specifications have not been applied, **or where relevant harmonised standards or common specifications do not exist**, the solutions adopted by the manufacturer meet the corresponding ~~essential~~ requirements of this Regulation;
- (5) agree with the manufacturer on a location where the examinations and tests will be carried out.

5. Evaluation report

The notified body shall draw up an evaluation report that records the activities undertaken in accordance with point 4 and their outcomes. Without prejudice to its obligations vis-à-vis the notifying authorities, the notified body shall release the content of that report, in full or in part, only with the agreement of the manufacturer.

6a. EU-type examination certificate

- 6.1. Where the type meets the requirements of this Regulation that apply to the ~~CE-marked~~ EU fertilising product concerned, the notified body shall issue an EU-type examination certificate to the manufacturer. The certificate shall contain the name and address of the manufacturer, the conclusions of the examination, the conditions (if any) for its validity and the necessary data for identification of the approved type. The certificate may have one or more annexes attached.
- 6.2. The certificate and its annexes shall contain all relevant information to allow the conformity of manufactured ~~CE-marked~~ EU fertilising products with the examined type to be evaluated ~~and to allow for further in-service control~~.
- 6.3. Where the type does not satisfy the requirements of this Regulation, the notified body shall refuse to issue an EU-type examination certificate and shall inform the applicant accordingly, giving detailed reasons for its refusal.

7a. Changes which may affect the conformity of the EU fertilising product

- 7.1. The notified body shall keep itself apprised of any changes in the generally acknowledged state of the art which indicate that the approved type may no longer comply with the requirements of this Regulation and shall determine whether such changes require further investigation. If so, the notified body shall inform the manufacturer accordingly.
- 7.2. The manufacturer shall inform the notified body that holds the technical documentation relating to the EU-type examination certificate of all modifications to the approved type that may affect the conformity of the ~~CE marked~~ **EU** fertilising product with the requirements of this Regulation or the conditions for validity of the certificate. Such modifications shall require additional approval in the form of an addition to the original EU-type examination certificate.

8a. Notified bodies' information obligations

- 8.1. Each notified body shall inform its notifying authority concerning the EU-type examination certificates and/or any additions thereto which it has issued or withdrawn, and shall, periodically or upon request, make available to its notifying authorities the list of certificates and/or any additions thereto refused, suspended or otherwise restricted.
- 8.2. Each notified body shall inform the other notified bodies concerning the EU-type examination certificates and/or any additions thereto which it has refused, withdrawn, suspended or otherwise restricted, and, upon request, concerning the certificates and/or additions thereto which it has issued.

8.3. The Commission, the Member States and the other notified bodies may, on request, obtain a copy of the EU-type examination certificates and/or additions thereto. On request, the Commission and the Member States may obtain a copy of the technical documentation and the results of the examinations carried out by the notified body.

8.4. The notified body shall keep a copy of the EU-type examination certificate, its annexes and additions, as well as the technical file including the documentation submitted by the manufacturer, until the expiry of the validity of the certificate.

9. **Availability of the EU-type examination certificate**

The manufacturer shall keep a copy of the EU-type examination certificate, its annexes and additions together with the technical documentation at the disposal of the national authorities for ~~10~~ **5** years after the ~~CE~~-marked **EU** fertilising product has been placed on the market.

10. **Authorised representative**

The manufacturer's authorised representative may lodge the application referred to in point 3 and fulfil the obligations set out in points 7 and 9, provided that they are specified in the mandate.

MODULE C –

CONFORMITY TO TYPE BASED ON INTERNAL PRODUCTION CONTROL

1. Description of the module

~~1.~~ Conformity to type based on internal production control is the part of a conformity assessment procedure whereby the manufacturer fulfils the obligations laid down in points 2 and 3, and ensures and declares that the ~~CE marked~~ EU fertilising products concerned are in conformity with the type described in the EU-type examination certificate and satisfy the requirements of this Regulation that apply to them.

2. Manufacturing

~~2.~~ The manufacturer shall take all measures necessary so that the manufacturing process and its monitoring ensure conformity of the manufactured ~~CE marked~~ EU fertilising products with the approved type described in the EU-type examination certificate and with the requirements of this Regulation that apply to them.

3. **Conformity CE marking and EU declaration of conformity**

- 3.1 The manufacturer shall affix the CE marking to each individual **packaging of the EU** fertilising product that is in conformity with the type described in the EU-type examination certificate and satisfies the **applicable** requirements of this Regulation **or, where it is supplied without packaging, in a document accompanying the EU fertilising product.**
- 3.2 The manufacturer shall draw up a written EU declaration of conformity for an ~~an CE-marked EU~~ fertilising product ~~of type~~ and keep it **together with the technical documentation** at the disposal of the national authorities for ~~10~~ **5** years after the ~~CE-marked EU~~ fertilising product has been placed on the market. The EU declaration of conformity shall identify the ~~CE marked EU~~ fertilising product ~~of type~~ for which it has been drawn up.
- 3.3. A copy of the EU declaration of conformity shall be made available to the relevant authorities upon request.

4. **Authorised representative**

4. The manufacturer's obligations set out in point 3 may be fulfilled by his or her authorised representative, on his or her behalf and under his or her responsibility, provided that they are specified in the mandate.

MODULE D1: QUALITY ASSURANCE OF THE PRODUCTION PROCESS

1. Description of the module

~~1-~~ Quality assurance of the production process is the conformity assessment procedure whereby the manufacturer of the ~~CE marked~~ **EU** fertilising product fulfils the obligations laid down under Headings 2, 4, and 7, and ensures and declares on his or her sole responsibility that the ~~CE marked~~ **EU** fertilising products concerned satisfy the requirements of this Regulation that apply to them.

2. Technical documentation

~~2-~~ The manufacturer of the ~~CE marked~~ **EU** fertilising product shall establish the technical documentation. The documentation shall make it possible to assess the **EU fertilising** product's conformity with the relevant requirements, and shall include an adequate analysis and assessment of the risk(s). The technical documentation shall specify the applicable requirements and cover, as far as relevant for the assessment, the design, manufacture and **intended** use of the **EU fertilising** product. The technical documentation shall, wherever applicable, contain at least the following elements:

~~(a) a general description of the product,~~

~~(b) conceptual design and manufacturing drawings and schemes, including a written description and a diagram of the production process, where each treatment, storage vessel and area is clearly identified,~~

~~(c) descriptions and explanations necessary for the understanding of those drawings and schemes and of the use of the CE marked **EU** fertilising product,~~

- (d) ~~a list of the harmonised standards applied in full or in part the references of which have been published in the Official Journal of the European Union and, where those harmonised standards have not been applied, descriptions of the solutions adopted to meet the essential requirements of this Regulation, including a list of common specifications or other relevant technical specifications applied. In the event of partly applied harmonised standards, the technical documentation shall specify the parts which have been applied,~~
- (e) ~~results of design calculations made, examinations carried out, etc.,~~
- (f) ~~test reports, and~~
- (g) ~~where the product contains or consists of products derived from animal by-products within the meaning of Regulation (EC) No 1069/2009, the commercial documents or health certificates required pursuant to that Regulation, and evidence that the animal by-derived products have reached the end point in the manufacturing chain within the meaning of that Regulation.~~
- (a) a general description of the EU fertilising product, the PFC corresponding to the claimed function of the product and description of the intended use,**
- (b) a list of component materials used, the CMCs to which they belong and information for their origin or manufacturing process,**
- (c) the EU declarations of conformity for the component EU fertilising products of the fertilising product blend,**

- ~~(ca) information about maximum quantity and source of total chromium Cr in a clear manner, if the actual concentration is above 200 mg/kg dry matter,~~
- ~~(d) conceptual design, drawings, schemes, descriptions and explanations necessary for the understanding of the manufacturing process of the EU fertilising product, including and, in relation to compost belonging to CMC 3 or digestate belonging to CMC 5, a written description and a diagram of the production process, where each treatment, storage vessel and area is clearly identified,~~
- ~~(e) a specimen of the label or the relevant accompanying document containing the information required in accordance with Annex III,~~
- ~~(f) a list of the harmonised standards referred to in Article 12, common specifications referred to in Article 13 and/or other relevant technical specifications applied. In the event of partly applied harmonised standards, the technical documentation shall specify the parts which have been applied,~~
- ~~(g) results of design calculations made, including the calculations to demonstrate conformity with point 4 of Part II of Annex I, examinations carried out, etc., and~~
- ~~(h) test reports, and~~
- ~~(i) where the product contains or consists of products derived from animal by-products within the meaning of Regulation (EC) No 1069/2009, the commercial documents or health certificates required pursuant to that Regulation, and evidence that the derived products have reached the end point in the manufacturing chain within the meaning of that Regulation;~~

3. Availability of technical documentation

- 3- The manufacturer shall keep the technical documentation at the disposal of the relevant national authorities for ~~10~~ **5** years after the ~~CE marked~~ **EU** fertilising product has been placed on the market.

4. Manufacturing

- 4- The manufacturer shall operate an approved quality system for production, final product inspection and testing of the products concerned as specified in point 5, and shall be subject to surveillance as specified in point 6.

5. Quality system

- 5.1. The manufacturer shall implement a quality system which shall ensure compliance of the ~~CE marked~~ **EU** fertilising product with the requirements of this Regulation that apply to them.

- 5.1.1. The quality system shall ~~include~~ **cover the** quality objectives and an organisational structure with responsibilities and powers of the management with regard to product quality.

- 5.1.1.1. For compost belonging to component material category ('CMC') 3 and digestate belonging to CMC 5, as defined in Annex II, senior management of the manufacturer's organisation shall:

- (a) Ensure that sufficient resources (people, infrastructure, equipment) are available to create and implement the quality system;

- (b) Appoint a member of the organisation's management who shall be responsible for:
- Ensuring that quality management processes are established, approved, implemented and maintained;
 - Reporting to senior management of the manufacturer on the performance of the quality management and any need for improvement;
 - Ensuring the promotion of awareness of customer needs and legal requirements throughout the manufacturer's organisation, and for making the personnel aware of the relevance and importance of the quality management requirements to meet the legal requirements of this Regulation;
 - Ensuring that each person whose duties affect the product quality is sufficiently trained and instructed; and
 - Ensuring the classification of the quality management documents mentioned under paragraph 5.1.4. below;
- (c) Conduct an internal audit every year, or sooner than scheduled if triggered by any significant change that may affect the quality of the ~~CE marked~~ EU fertilising product; and
- (d) Ensure that appropriate communication processes are established within and outside the organisation and that communication take place regarding the effectiveness of the quality management.

5.1.2. The quality system shall ~~be implemented through~~ **cover the** manufacturing, quality control and quality assurance techniques, processes and systematic actions.

5.1.2.1. For compost belonging to component material category ('CMC') 3 and digestate belonging to CMC 5, as defined in Annex II, the system shall ensure compliance with the composting and digestion process criteria specified in that Annex.

5.1.3. The quality system shall ~~comprise~~ **cover the** examinations and tests to be carried out before, during and after manufacture with a specified frequency.

5.1.3.1. For compost belonging to CMC 3 and digestate belonging to CMC 5, as defined in Annex II, the examinations and tests shall comprise the following elements:

- (a) The following information shall be recorded for each lot of input materials:
 - (1) Date delivered;
 - (2) Amount by weight (or estimation based on the volume and density);
 - (3) Identity of the input material supplier;
 - (4) Input material type;
 - (5) Identification of each lot and delivery location on site. A unique identification code shall be assigned throughout the production process for quality management purposes; and
 - (6) In case of refusal, the reasons for the rejection of the lot and where it was sent.

- (b) Qualified staff shall carry out a visual inspection of each consignment of input materials and verify compatibility with the specifications of input materials in CMC 3 and CMC 5 in Annex II.
- (c) The manufacturer shall refuse any consignment of any given input material where visual inspection raises any suspicion of
- the presence of hazardous or damageable substances for the composting or digestion process or for the quality of the final ~~CE-marked~~ EU fertilising product, or of
 - incompatibility with the specifications of CMC 3 and CMC 5 in Annex II, in particular by presence of plastics leading to exceedence of the limit value for macroscopic impurities.
- (d) The staff shall be trained on
- potential hazardous properties that may be associated with input materials, and
 - features that allow hazardous properties and the presence of plastics to be recognised.
- (e) Samples shall be taken on output materials, to verify that they comply with the component material specifications for compost and digestate laid down in CMC 3 and CMC 5 in Annex II, and that the properties of the output material does not jeopardise the ~~CE-marked~~ EU fertilising product's compliance with the relevant requirements in Annex I.

- (f) The output material samples shall be taken **on a regular basis** with at least the following frequency:

Annual input (tonnes)	Samples / year
≤ 3000	1
3001 – 10000	2
10001 – 20000	3
20001 – 40000	4
40001 – 60000	5
60001 – 80000	6
80001 – 100000	7
100001 – 120000	8
120001 – 140000	9
140001 – 160000	10
160001 – 180000	11
> 180000	12

(g) If any tested output material sample fails one or more of the applicable limits specified in the relevant sections of Annexes I and II to this Regulation, the person responsible for quality management referred to above in point 5.1.1.1(b) shall:

- (1) Clearly identify the non-conforming ~~products~~ **output materials** and their storage place,
- (2) Analyse the reasons of the non-conformity and take any necessary action to avoid its repetition,
- (3) Record in the quality records referred to in paragraph 5.1.4 if reprocessing takes place, or if the ~~product~~ **output material** is eliminated.

5.1.4. **The quality system shall cover the** ~~the manufacturer's shall maintain the~~ quality records, such as inspection reports and test data, calibration data, qualification reports on the personnel concerned, etc.,

5.1.4.1. For compost belonging to component material category ('CMC') 3 and digestate belonging to CMC 5, as defined in Annex II, the quality records shall demonstrate effective control of input materials, production, storage and compliance of input- and output materials with the relevant requirements of this Regulation. Each document shall be legible and available at its relevant place(s) of use, and any obsolete version shall be promptly removed from all places where it is used, or at least identified as obsolete. The quality management documentation shall at least contain the following information:

- (a) A title,
- (b) A version number,
- (c) A date of issue,

- (d) The name of the person who issued it,
- (e) Records about the effective control of input materials,
- (f) Records about the effective control of the production process,
- (g) Records about the effective control of the output materials,
- (h) Records of non-conformities,
- (i) Reports on all accidents and incidents that occur to the site, their known or suspected causes and actions taken,
- (j) Records of the complaints expressed by third parties and how they have been addressed,
- (k) A record of the date, type and topic of training followed by the persons responsible for the quality of the product,
- (l) Results of internal audit and actions taken, and
- (m) Results of external audit review and actions taken.

5.1.5 **The quality system shall cover the means of monitoring** ~~the~~ the achievement of the required product quality and the effective operation of the quality system ~~shall be monitored~~.

5.1.5.1. For compost belonging to component material category ('CMC') 3 and digestate belonging to CMC 5, as defined in Annex II, the manufacturer shall establish an annual internal audit program in order to verify the compliance to the quality system, with the following components:

- (1) A procedure that defines the responsibilities and requirements for planning and conducting internal audits, establishing records and reporting results shall be established and documented. A report identifying the non-conformities to the quality scheme shall be prepared and all corrective actions shall be reported. The records of the internal audit shall be annexed to the quality management documentation.
- (2) Priority shall be given to non-conformities identified by external audits.
- (3) Each auditor shall not audit his or her own work.
- (4) The management responsible for the area audited shall ensure that the necessary corrective actions are taken without undue delay.
- (5) Internal audit realised in the frame of another quality management system can be taken into account provided that it is completed by an audit of the requirements to this quality system.

5.1.5a. All the elements, requirements and provisions adopted by the manufacturer shall be documented in a systematic and orderly manner in the form of written policies, procedures and instructions. The quality system documentation shall permit a consistent interpretation of the quality programmes, plans, manuals and records. It shall, in particular, contain an adequate description of all the quality management elements set out in points 5.1.1-5.1.5.

5.2. The manufacturer shall lodge an application for assessment of his or her quality system with the ~~accredited~~ notified body of his or her choice, for the products concerned. The application shall include:

- the name and address of the manufacturer and, if the application is lodged by the authorised representative, his or her name and address as well,
- a written declaration that the same application has not been lodged with any other notified body,
- all relevant information for the product category envisaged,
- the documentation concerning the quality system, **containing all the elements set out in point 5.1,**
- **the** technical documentation **referred to in point 2** of all the ~~quality system elements set out in paragraphs 5.1 and subparagraphs.~~

~~5.3. All the elements, requirements and provisions adopted by the manufacturer shall be documented in a systematic and orderly manner in the form of written policies, procedures and instructions. The quality system documentation shall permit a consistent interpretation of the quality programmes, plans, manuals and records. It shall, in particular, contain an adequate description of all the quality management elements mentioned above in paragraph 5.1 and subparagraphs.~~

5.4.1. The notified body shall assess the quality system to determine whether it satisfies the requirements referred to in ~~paragraph~~ **point** 5.1 ~~and subparagraphs~~.

5.4.2. It shall presume conformity with those requirements in respect of the elements of the quality system that comply with the corresponding specifications of the relevant harmonised standard.

5.4.3. In addition to experience in quality management systems, the auditing team shall have at least one member with experience of evaluation in the relevant product field and product technology concerned, and knowledge of the applicable requirements of this Regulation. The audit shall include an assessment visit to the manufacturer's premises. The auditing team shall review the technical documentation referred to in point 2 in order to verify the manufacturer's ability to identify the relevant requirements of this Regulation and to carry out the necessary examinations with a view to ensuring compliance of the ~~CE marked~~ **EU** fertilising product with those requirements.

5.4.4. The decision shall be notified to the manufacturer. The notification shall contain the conclusions of the audit and the reasoned assessment decision.

5.5. The manufacturer shall undertake to fulfil the obligations arising out of the quality system as approved and to maintain it so that it remains adequate and efficient

5.6.1. The manufacturer shall keep the notified body that has approved the quality system informed of any intended change to the quality system.

5.6.2. The notified body shall evaluate any proposed changes and decide whether the modified quality system will continue to satisfy the requirements referred to in point 5.2 or whether reassessment is necessary.

5.6.3. It shall notify the manufacturer of its decision. The notification shall contain the conclusions of the examination and the reasoned assessment decision.

6. Surveillance under the responsibility of the notified body

6.1 The purpose of surveillance is to make sure that the manufacturer duly fulfils the obligations arising out of the approved quality system.

6.2. The manufacturer shall, for assessment purposes, allow the notified body access to the manufacture, inspection, testing and storage sites and shall provide it with all necessary information, in particular:

- the quality system documentation,
- the technical documentation referred to in paragraph 2,
- the quality records, such as inspection reports and test data, calibration data, qualification reports on the personnel concerned.

6.3.1 The notified body shall carry out periodic audits to make sure that the manufacturer maintains and applies the quality system and shall provide the manufacturer with an audit report.

6.3.2 For compost belonging to component material category ('CMC') 3 and digestate belonging to CMC 5, as defined in Annex II, the notified body shall take and analyse output material samples during each audit, and the audits shall be carried out with the following frequency:

- (a) During the notified body's first year of surveillance of the plant in question: The same frequency as the sampling frequency indicated in the table included in paragraph 5.1.3.1(f); and
- (b) During the following years of surveillance: Half the sampling frequency indicated in the table included in paragraph 5.1.3.1(f).

6.4 In addition, the notified body may pay unexpected visits to the manufacturer. During such visits the notified body may, if necessary, carry out product tests, or have them carried out, in order to verify that the quality system is functioning correctly. The notified body shall provide the manufacturer with a visit report and, if tests have been carried out, with a test report.

7. ~~Conformity~~ CE marking and EU declaration of conformity

7.1. The manufacturer shall affix the CE marking and, under the responsibility of the notified body referred to in ~~paragraph~~ point 5.2, the latter's identification number to each individual **packaging of the EU fertilising** product that satisfies the applicable requirements of this Regulation **or, where it is supplied without packaging, in a document accompanying the EU fertilising product.**

7.2.1 The manufacturer shall draw up a written EU declaration of conformity for ~~each~~ an-~~CE~~ EU fertilising product ~~lot~~ or type and keep it **together with the technical documentation** at the disposal of the national authorities for ~~10~~ 5 years after the ~~CE~~ EU fertilising product has been placed on the market. The EU declaration of conformity shall identify the **EU fertilising** product ~~or~~ lot type for which it has been drawn up. **In case of a change within the meaning of Article 6(4) the manufacturer shall draw up a new EU declaration of conformity.**

7.2.2. A copy of the EU declaration of conformity shall be made available to the relevant authorities upon request.

8. Availability of quality system documentation

8. The manufacturer shall, for a ~~period ending at least 10~~ **5** years after the product has been placed on the market, keep at the disposal of the national authorities:

- the documentation referred to in ~~paragraph~~ **point** 5.3,
- the **information on the** changes referred to in ~~paragraph~~ **point** 5.6 and ~~subparagraphs~~, as approved,
- the decisions and reports of the notified body referred to in ~~paragraph~~ **points** 5.6.1, 5.6.3, ~~paragraph~~ **point** 6.3.1 and ~~paragraph~~ **point** 6.4.

9. Notified bodies' information obligation

9.1. Each notified body shall inform its notifying authorities of quality system approvals issued or withdrawn, and shall, periodically or upon request, make available to its notifying authorities the list of quality system approvals refused, suspended or otherwise restricted.

9.2. Each notified body shall inform the other notified bodies of quality system approvals which it has refused, suspended, ~~or~~ withdrawn **or otherwise restricted**, and, upon request, of quality system approvals which it has issued.

10. Authorised representative

The manufacturer's obligations set out in ~~paragraph~~ **point** 3, ~~paragraph~~ **point** 5.2, ~~paragraphs~~ **points** 5.6.1-5.6.3, ~~Heading~~ **point** 7 and ~~Heading~~ **point** 8 may be fulfilled by his or her authorised representative, on his or her behalf and under his or her responsibility, provided that they are specified in the mandate.

EU Declaration of conformity (No XXX)³⁹

1. ~~CE-marked~~ **EU** fertilising product (product-, batch-, **or** type- ~~or serial-~~ number):
 2. Name and address of the manufacturer and, where applicable, its authorised representative:
 3. This EU declaration of conformity is issued under the sole responsibility of the manufacturer.
 4. Object of the declaration (identification of product allowing traceability; it may, where necessary for the identification of the ~~CE-marked~~ **EU** fertilising product, include an image):
 5. The object of the declaration described above is in conformity with ~~the relevant Union harmonisation legislation~~
 - **Regulation [Publication office, please, insert the number of this Regulation],**
 - **other Union harmonisation legislation where applicable:**
 6. References to the relevant harmonised standards ~~used~~ or **to the common specifications used** **or** references to the other technical specifications in relation to which conformity is declared:
 7. Where applicable, the notified body ... (name, number) performed ... (description of intervention) and issued the certificate **or approval decision... (number):**
- 7a. Where applicable, annexed to this EU declaration of conformity are the EU declarations of conformity for the component EU fertilising products of the fertilising product blend.**
8. Additional information:

Signed for and on behalf of:

(place and date of issue):

(name, function) (signature):

³⁹ It is optional for the manufacturer to assign a number to the EU declaration of conformity.